

140129BT CAPARRELLA HIGH VALLEY FARMS

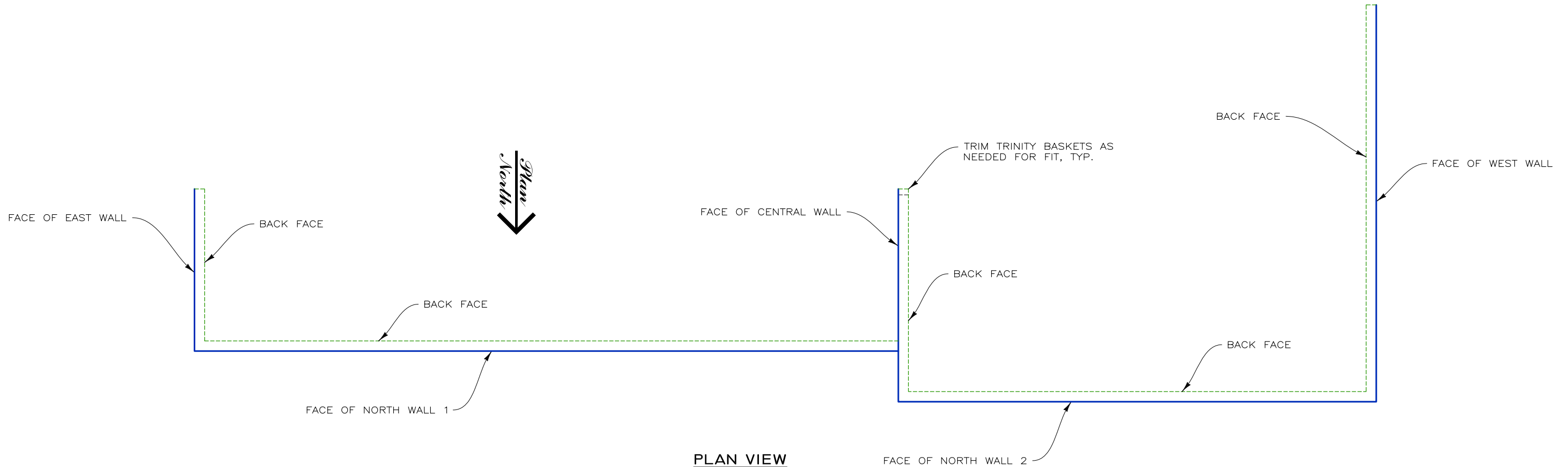

PLAN VIEW
SCALE: 1" = 10'

SUPPLIED QUANTITY			
SIZE LxWxH	CY	REQUIRED AMOUNT	TOTAL CY
6x1x13.5	3.00	6	18.00 CY
4x1x13.5	2.00	1	2.00 CY
6x1x9.5	2.11	6	12.66 CY
4x1x9.5	1.47	1	1.47 CY
6x1x7.5	1.67	1	1.67 CY
4x1x7.5	1.11	1	1.11 CY
6x1x6	1.33	2	2.66 CY
4x1x6	0.89	1	0.89 CY
6x1x2.5	0.56	13	7.28 CY
4x1x2.5	0.37	3	1.11 CY
TOTALS			48.85 CY

PROJECT-SPECIFIC NOTES:

1. REFERENCE DRAWINGS: PLANS FROM ROWLAND AND BROUGHTON PLANS ISSUED 21 NOVEMBER 2013. SHEETS A2.10, A4.1, A4.2, A5.1, A5.2, S3.00, S3.02 AND S3.03.
2. BLACK AND WHITE REPRODUCTION OF THIS COLOR ORIGINAL MAY REDUCE ITS EFFECTIVENESS AND LEAD TO INCORRECT INTERPRETATION.
3. METHOD OF TRINITY BASKET CONNECTION AND HARDWARE REQUIRED TO BE DETERMINED BY THE PROJECT ARCHITECT/ENGINEER.
4. THIS IS NOT AN ENGINEERED DRAWING. SHOP DRAWING IS SUPPLIED FOR TRINITY BASKET LAYOUT ONLY. IF CONFLICTS OR DISCREPANCIES ARISE, THE PROJECT PLANS SUPERCEDE THESE DOCUMENTS
5. THE BASE OF TRINITY BASKETS IS ASSUMED TO BE FOUNDED ON COMPETENT MATERIAL AS DETERMINED BY THE PROJECT ARCHITECT/ENGINEER.

THIS DRAWING IS FURNISHED SOLELY FOR THE USE OF OR IN CONNECTION WITH THIS PROJECT AND THE PROPRIETARY INFORMATION SHOWN HEREON IS NOT TO BE TRANSMITTED TO ANY OTHER ORGANIZATION WITHOUT SPECIFIC AUTHORIZATION BY THE HILFIKER COMPANY. HILFIKER RETAINING WALLS ARE PROTECTED BY ONE OR MORE OF THE FOLLOWING PATENTS: 243,613; 243,697; 288,616; 4,117,686; 4,329,089; 4,324,508; 4,391,557; 4,505,621; 4,343,318; 4,661,023; 4,856,939; 4,929,125; 5,076,735; 5,647,695; 5,722,799; 5,733,072; 6,357,970B1; 6,874,975B2; 7,033,118B2; AND OTHERS. OTHER PATENTS PENDING (2008)

REV.NO.	DATE	BY	DESCRIPTION
1	21 AUG 14	AMJ	CORRECTED TRINITY BASKET WIRE SPACING
2	29 AUG 14	AMJ	REDUCED BASKET DEPTH FROM 2' TO 1'

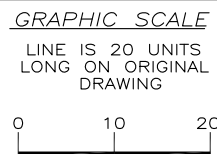

PROJ. MGR.
HKH
ENGINEER
CADD BY
AMJ

HILFIKER RETAINING WALLS

1902 Hilfiker Lane
Eureka, CA 95503-5711
TOLL-FREE 800.762.8962
PH 707.443.5093 FAX 707.443.2891
WEBSITE www.hilfiker.com E-MAIL Info@hilfiker.com

DWG DATE
18 JUL 14
REVISION DATE
29 AUG 14
SCALE
NOTED

SHOP DRAWING - TRINITY LAYOUT

TRINITY WALL
CAPARRELLA HIGH VALLEY FARMS
COOPER MASON VENTURES
24480 HWY. 82, BASALT, COLORADO

NOTES AND PLAN VIEW

PROJECT NO.
140129BT
SHEET
1
OF 4

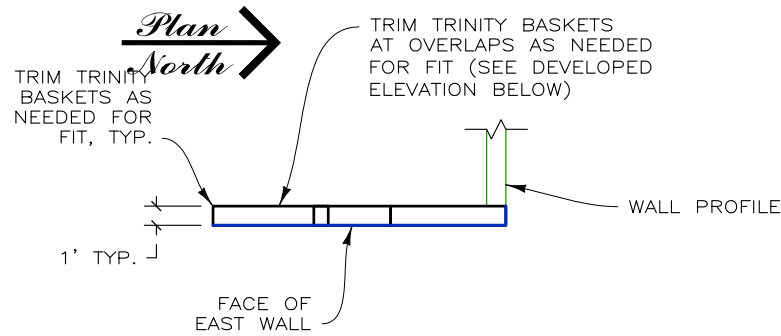

PLAN VIEW - EAST WALL
SCALE: 1" = 10'

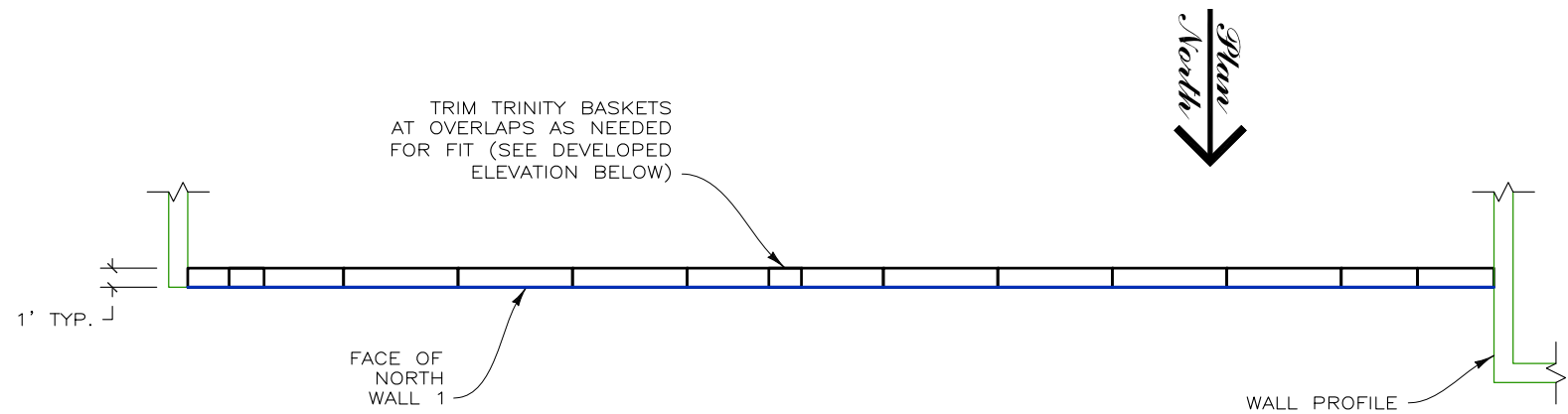

PLAN VIEW - NORTH WALL 1
SCALE: 1" = 10'

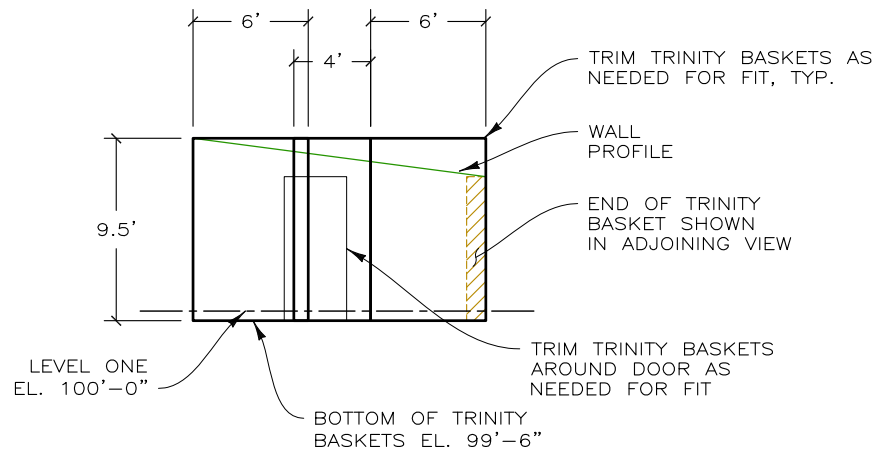

DEVELOPED ELEVATION - EAST WALL
SCALE: 1" = 10'

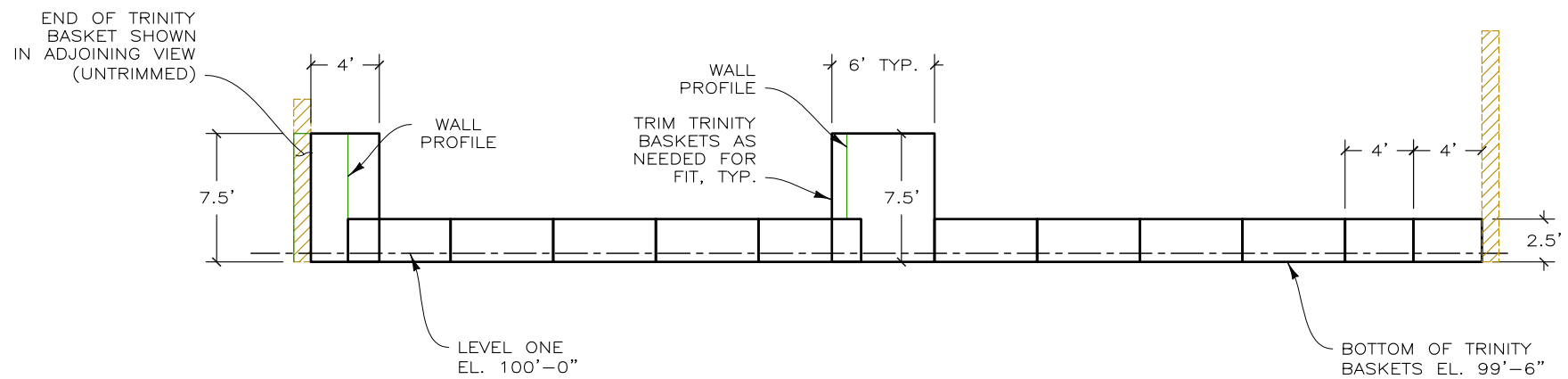

DEVELOPED ELEVATION - NORTH WALL 1
SCALE: 1" = 10'

HATCHING DENOTES ENDS OF TRINITY BASKETS SHOWN IN ADJOINING WALL VIEWS. COMPARE PLAN AND ELEVATION VIEWS TO DETERMINE IF THE END OF BASKET IS TO BE TRIMMED, HIDDEN OR EXPOSED.

140129BT CAPARRELLA HIGH VALLEY FARMS

THIS DRAWING IS FURNISHED SOLELY FOR THE USE OF OR IN CONNECTION WITH THIS PROJECT AND THE PROPRIETARY INFORMATION SHOWN HEREON IS NOT TO BE TRANSMITTED TO ANY OTHER ORGANIZATION WITHOUT SPECIFIC AUTHORIZATION BY THE HILFIKER COMPANY. HILFIKER RETAINING WALLS ARE PROTECTED BY ONE OR MORE OF THE FOLLOWING PATENTS: 2,433,613; 2,433,697; 2,886,616; 4,117,686; 4,329,089; 4,324,508; 4,391,557; 4,505,621; 4,343,318; 4,661,023; 4,856,939; 4,929,125; 5,076,735; 5,647,695; 5,722,799; 5,733,072; 6,357,970B1; 6,874,975B2; 7,033,118B2; AND OTHERS. OTHER PATENTS PENDING (2008)

REV.NO.	DATE	BY	DESCRIPTION
1	21 AUG 14	AMJ	CORRECTED TRINITY BASKET WIRE SPACING
2	29 AUG 14	AMJ	REDUCED BASKET DEPTH FROM 2' TO 1'

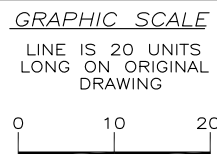

PROJ. MGR.
HKH
ENGINEER
CADD BY
AMJ

HILFIKER RETAINING WALLS

1902 Hilfiker Lane
Eureka, CA 95503-5711
TOLL-FREE 800.762.8962
PH 707.443.5093 FAX 707.443.2891
WEBSITE www.hilfiker.com E-MAIL info@hilfiker.com

DWG DATE
18 JUL 14
REVISION DATE
29 AUG 14
SCALE
NOTED

SHOP DRAWING - TRINITY LAYOUT
TRINITY WALL
CAPARRELLA HIGH VALLEY FARMS
COOPER MASON VENTURES
24480 HWY. 82, BASALT, COLORADO
EAST WALL & NORTH WALL 1 VIEWS

PROJECT NO.
140129BT
SHEET
2
OF 4

140129BT CAPARRELLA HIGH VALLEY FARMS

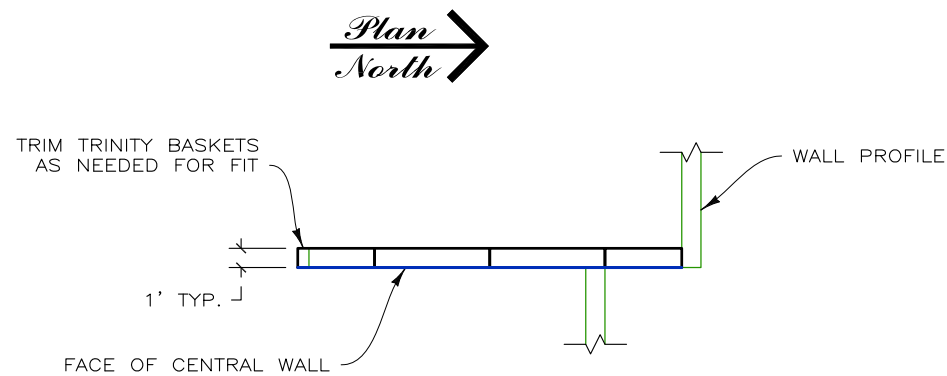

PLAN VIEW - CENTRAL WALL
SCALE: 1" = 10'

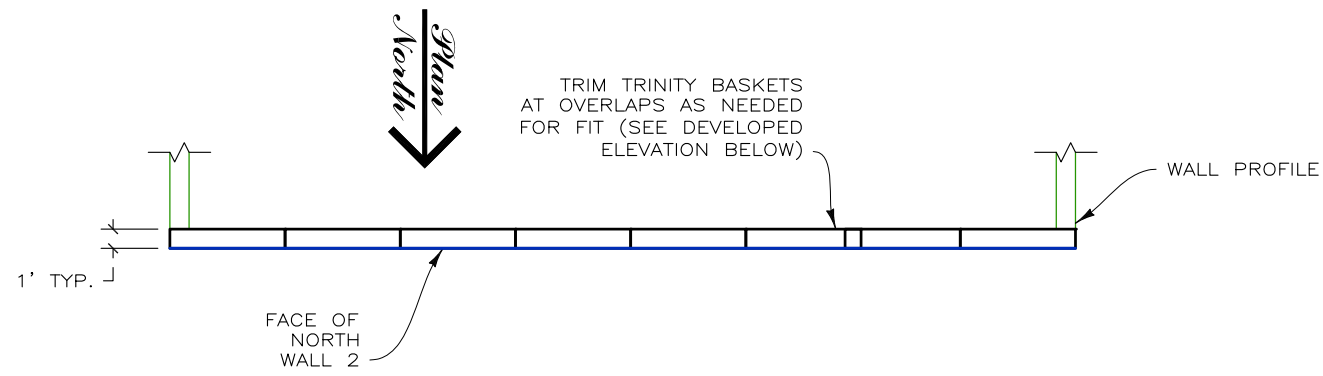

PLAN VIEW - NORTH WALL 2
SCALE: 1" = 10'

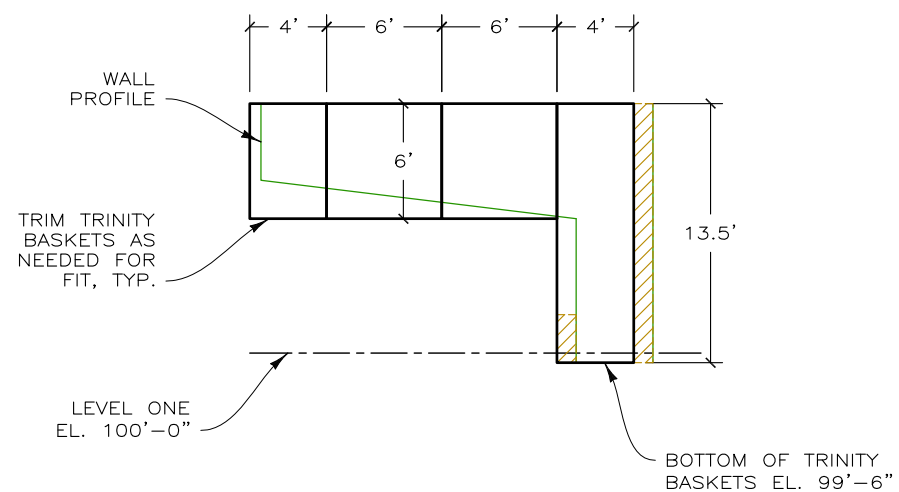

DEVELOPED ELEVATION - CENTRAL WALL
SCALE: 1" = 10'

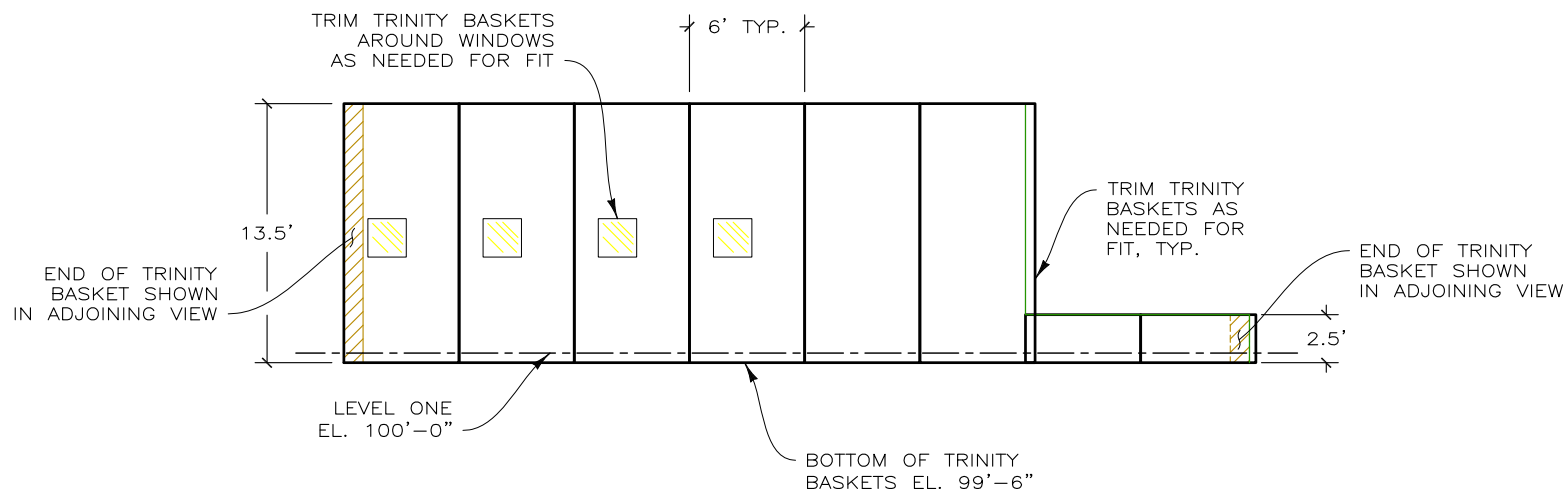

DEVELOPED ELEVATION - NORTH WALL 2
SCALE: 1" = 10'

HATCHING DENOTES ENDS OF TRINITY BASKETS SHOWN IN ADJOINING WALL VIEWS. COMPARE PLAN AND ELEVATION VIEWS TO DETERMINE IF THE END OF BASKET IS TO BE TRIMMED, HIDDEN OR EXPOSED.

THIS DRAWING IS FURNISHED SOLELY FOR THE USE OF OR IN CONNECTION WITH THIS PROJECT AND THE PROPRIETARY INFORMATION SHOWN HEREON IS NOT TO BE TRANSMITTED TO ANY OTHER ORGANIZATION WITHOUT SPECIFIC AUTHORIZATION BY THE HILFIKER COMPANY. HILFIKER RETAINING WALLS ARE PROTECTED BY ONE OR MORE OF THE FOLLOWING PATENTS: 243,613; 243,697; 288,616; 4,117,686; 4,329,089; 4,324,508; 4,391,557; 4,505,821; 4,343,318; 4,661,023; 4,856,939; 4,929,125; 5,076,735; 5,647,695; 5,722,799; 5,733,072; 6,357,970B1; 6,874,975B2; 7,033,118B2; AND OTHERS. OTHER PATENTS PENDING (2008)

REV.NO.	DATE	BY	DESCRIPTION
1	21 AUG 14	AMJ	CORRECTED TRINITY BASKET WIRE SPACING
2	29 AUG 14	AMJ	REDUCED BASKET DEPTH FROM 2' TO 1'

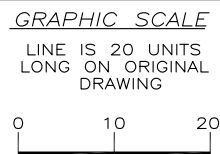

PROJ. MGR.
HKH
ENGINEER
CADD BY
AMJ

HILFIKER RETAINING WALLS

1902 Hilfiker Lane
Eureka, CA 95503-5711
TOLL-FREE 800.762.8962
PH 707.443.5093 FAX 707.443.2891
WEBSITE www.hilfiker.com E-MAIL Info@hilfiker.com

DWG DATE
18 JUL 14
REVISION DATE
29 AUG 14
SCALE
NOTED

SHOP DRAWING - TRINITY LAYOUT
TRINITY WALL
CAPARRELLA HIGH VALLEY FARMS
COOPER MASON VENTURES
24480 HWY. 82, BASALT, COLORADO
CENTRAL WALL & NORTH 2 WALL VIEWS

PROJECT NO.
140129BT
SHEET
3
OF 4

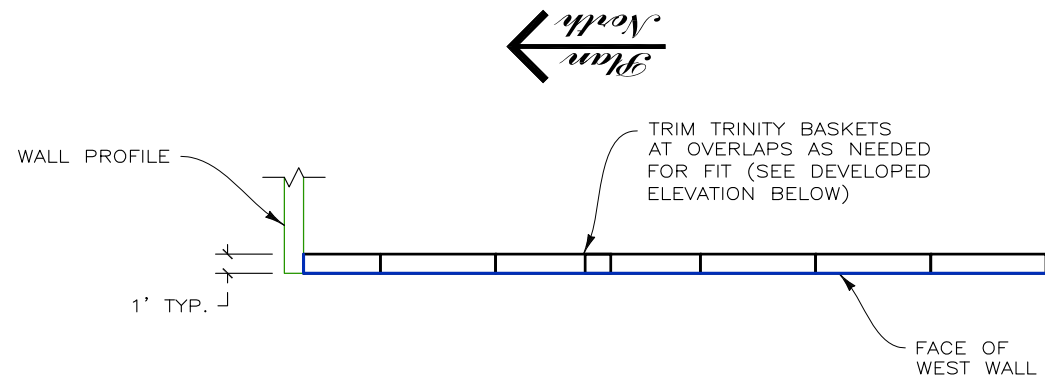

PLAN VIEW - WEST WALL
SCALE: 1" = 10'

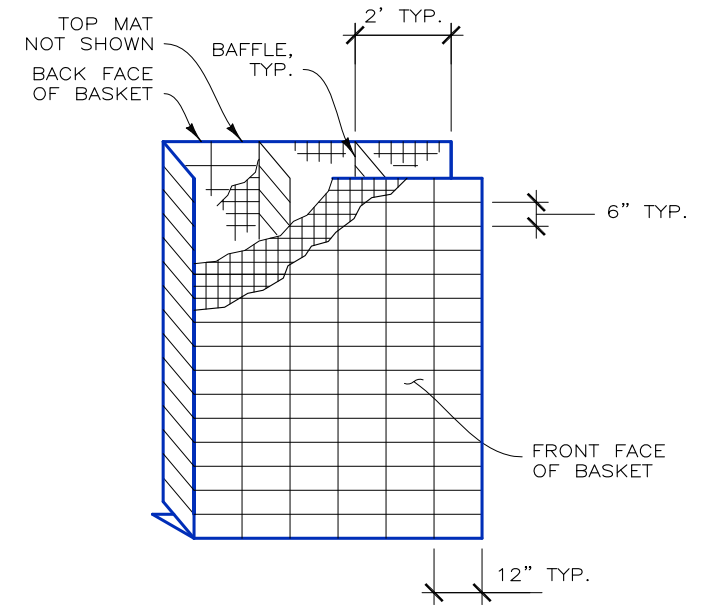

ISOMETRIC OF TRINITY BASKETS
NOT TO SCALE

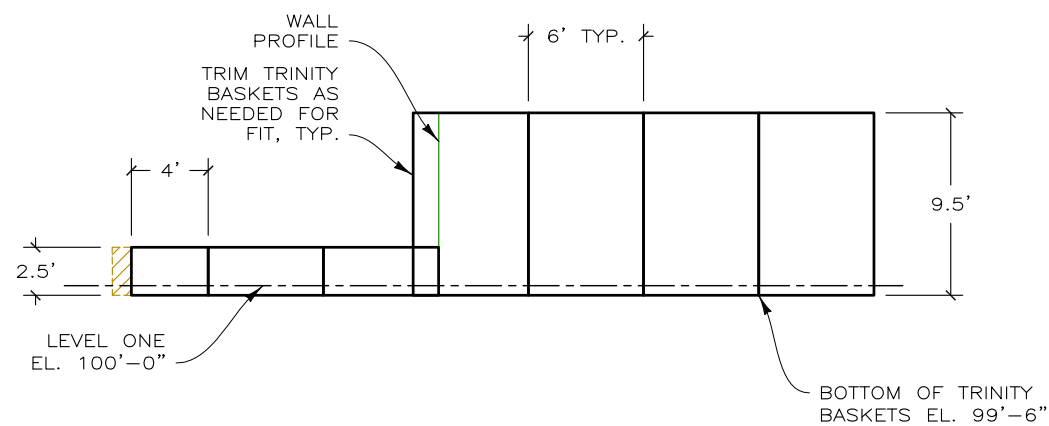

DEVELOPED ELEVATION - WEST WALL
SCALE: 1" = 10'

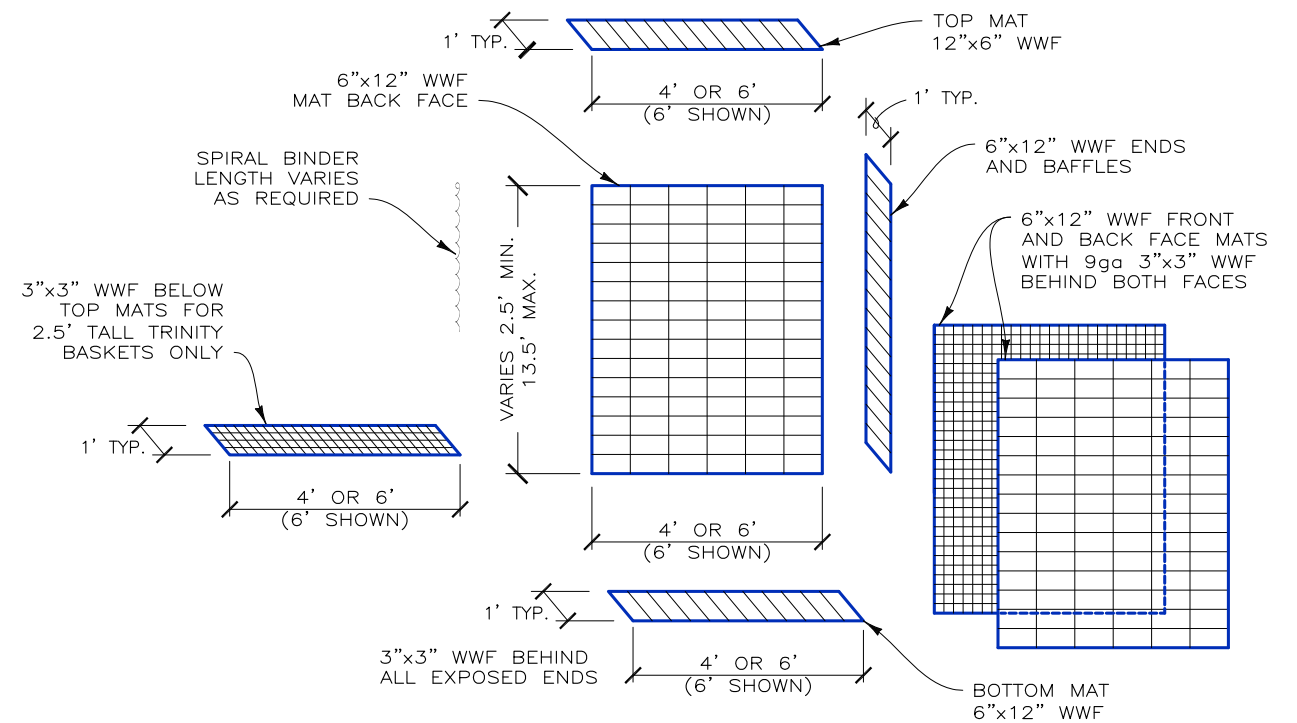

TRINITY BASKET WALL COMPONENTS
NOT TO SCALE

HATCHING DENOTES ENDS OF TRINITY BASKETS SHOWN IN ADJOINING WALL VIEWS. COMPARE PLAN AND ELEVATION VIEWS TO DETERMINE IF THE END OF BASKET IS TO BE TRIMMED, HIDDEN OR EXPOSED.

140129BT CAPARRELLA HIGH VALLEY FARMS

THIS DRAWING IS FURNISHED SOLELY FOR THE USE OF OR IN CONNECTION WITH THIS PROJECT AND THE PROPRIETARY INFORMATION SHOWN HEREON IS NOT TO BE TRANSMITTED TO ANY OTHER ORGANIZATION WITHOUT SPECIFIC AUTHORIZATION BY THE HILFIKER COMPANY. HILFIKER RETAINING WALLS ARE PROTECTED BY ONE OR MORE OF THE FOLLOWING PATENTS: 243,613; 243,697; 288,616; 4,117,686; 4,329,089; 4,324,508; 4,391,557; 4,505,821; 4,343,318; 4,661,023; 4,856,939; 4,929,125; 5,076,735; 5,647,695; 5,722,799; 5,733,072; 6,357,970B1; 6,874,975B2; 7,033,118B2; AND OTHERS. OTHER PATENTS PENDING (2008)

REV.NO.	DATE	BY	DESCRIPTION
1	21 AUG 14	AMJ	CORRECTED TRINITY BASKET WIRE SPACING
2	29 AUG 14	AMJ	REDUCED BASKET DEPTH FROM 2' TO 1'

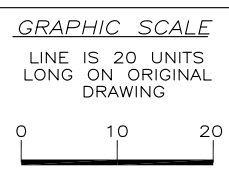

PROJ. MGR.
HKH
ENGINEER
CADD BY
AMJ

HILFIKER RETAINING WALLS

1902 Hilfiker Lane
Eureka, CA 95503-5711
TOLL-FREE 800.762.8962
PH 707.443.5093 FAX 707.443.2891
WEBSITE www.hilfiker.com E-MAIL Info@hilfiker.com

DWG DATE
18 JUL 14
REVISION DATE
29 AUG 14
SCALE
NOTED

SHOP DRAWING - TRINITY LAYOUT

TRINITY WALL
CAPARRELLA HIGH VALLEY FARMS
COOPER MASON VENTURES
24480 HWY. 82, BASALT, COLORADO

WEST WALL VIEWS & TRINITY DETAILS

PROJECT NO.
140129BT
SHEET
4
OF 4