

**DESIGN NOTES**

- Design is based on the assumption that backfill within the reinforced soil mass, methods of construction and quality of materials conform to the requirements of Hilfiker Retaining Walls.
- Assumed Soil Characteristics:  
 Wall Backfill:  
 Unit Weight: 130 pcf  
 Internal Friction Angle: 34°  
 Cohesion = 0 psf  
 Retained Backfill:  
 Unit Weight: 125 pcf  
 Internal Friction Angle: 36°  
 Cohesion = 650 psf  
 Foundation Soils:  
 Unit Weight: 125 pcf  
 Internal Friction Angle: 36°  
 Cohesion = 650 psf  
 Traffic Surcharge Loading (LL) = 250 psf

- If during construction, the wall location, structure location or loads are different than that proposed in this plan set and calculation package, HRW shall be notified to evaluate the need for a redesign.
- The design requires a non-saturated backfill. Surface and sub-surface drainage control may be required to prevent saturation of the backfill or relieve hydrostatic pressures.
- Design Procedure:  
 Mechanically Stabilized Earth walls and Reinforced Soil Slopes, FHWA report No. FHWA-NHI-00-043.

- All information hereon is derived from the reference drawings, and is subject to geometric and geotechnical confirmation. The applicable Hilfiker construction guide and specifications are an integral part of this submittal.
- Hilfiker Retaining Walls shall be responsible only for the internal stability of the retaining wall, and not for global stability or foundation bearing capacity. The Contracting Officer (CO) shall be responsible for global stability and foundation competence. The CO is responsible for all job site drainage, safety and fall protection provisions for workers in compliance with OSHA and any other applicable requirements.

SUPPLIED QUANTITIES	
WALL NO.	FACE AREA
SITE 1	608 SQ. FT.
SITE 2	4,496 SQ. FT.
TOTALS	5,104 SQ. FT.

**Worst Case Factored Bearing Pressure (Static/ Limit State Strength I) by MSE Wall- @ 38' Height - 7470 psf.**

If actual characteristics, grades or dimensions of soil materials differ from those listed above or shown on the plans, Hilfiker Retaining walls shall be notified to evaluate the need to redesign.

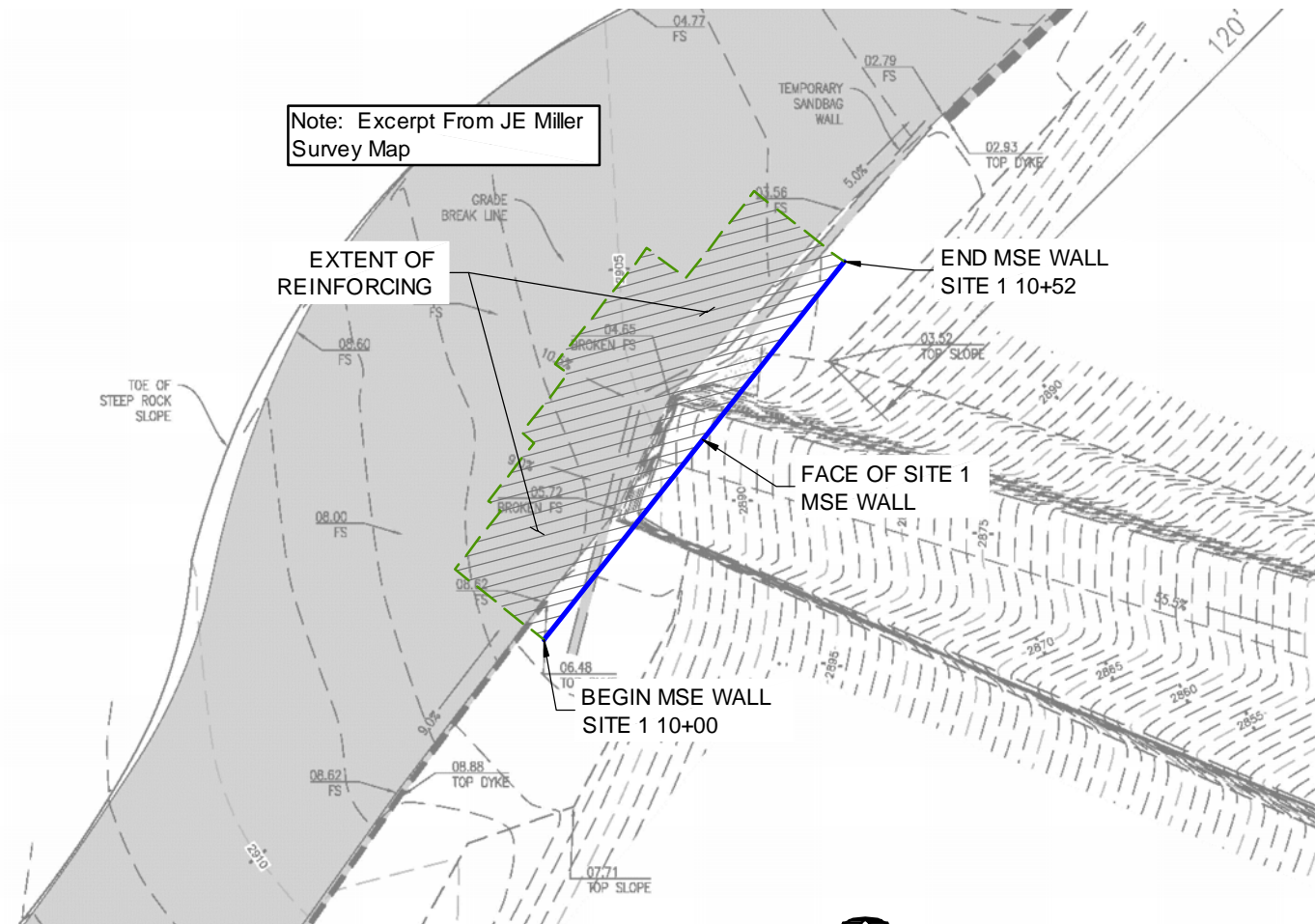

**SITE 1 - PLAN VIEW**  
 SCALE: 1" = 20'

THE DESIGN CONTAINED ON THESE DRAWINGS IS BASED ON INFORMATION PROVIDED BY THE OWNER. ON THE BASIS OF THIS INFORMATION, THE HILFIKER COMPANY HAS DESIGNED, AND IS RESPONSIBLE FOR THE INTERNAL STABILITY OF THE STRUCTURE ONLY. EXTERNAL STABILITY, INCLUDING FOUNDATION AND SLOPE STABILITY, IS THE RESPONSIBILITY OF THE OWNER.

REV. NO.	DATE	BY	DESCRIPTION
	10-25-19	KLC	Initial .pdf Release

**HILFIKER RETAINING WALLS**

1902 Hilfiker Lane  
 Eureka, CA 95503-5711  
 TOLL-FREE 800.762.8962  
 PH 707.443.5093 FAX 707.443.2891  
 WEB SITE www.hilfiker.com E-MAIL info@hilfiker.com

**CESARETTI**  
 Engineered Solutions  
 CIVIL ENGINEERING SPECIALISTS

P.O. Box 132  
 Fortuna, CA 95540  
 Phone (707) 725-CESR  
 (707) 498-7193  
 CesarettiEngineered.com  
 KCesaretti@att.net

CA ERFO ANGELES NF 3N17(2) SANTA CLARA DIVIDE  
 MSE WELDED WIRE WALL  
 SITE 1 - PLAN VIEW & GENERAL NOTES

HW 190814AW

PROJECT	19-055
DATE	10-25-19
DESIGN	KLC
DRAWN	KLC
SHT	1 OF 6

SITE 1 - WELDED WIRE WALL PARAMETERS			
Height of Wall (H) ft	Length of Cap & Prongless Mats (B <sub>1</sub> ) ft	Base Length of TOP Std Mat (B <sub>2</sub> ) ft	Base Length of Lower Std Mats (B <sub>3</sub> ) ft
≤10'	12.0'	12.25'	8.75'
12'	14.0'	14.0'	10.5'
14'	15.0'	15.75'	12.25'
16'	17.0'	17.5'	14.0'

Cap & Top Mats (B<sub>1</sub>) are: 8x12 W4.5x3.5 WWR (Type 1)  
 Standard Mats (B<sub>2</sub>) are: 8x21 W7.0x4.0 WWR (Type 2)  
                                   8x21 W9.5x4.0 WWR (Type 3)  
 Finish: Hot Dip Galvanized - 75 Year Service Life

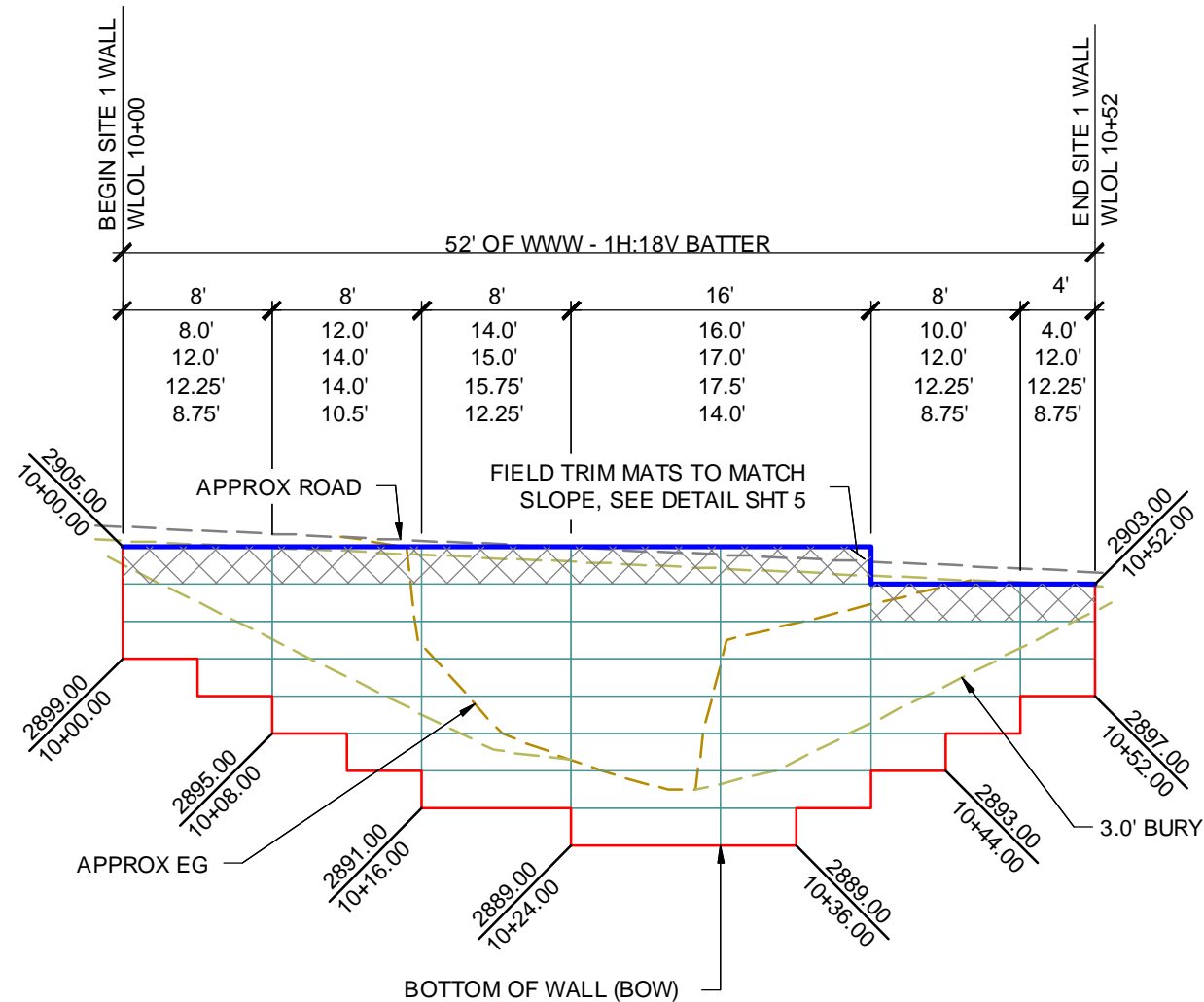

- WALL WIRE TYPE LEGEND**
- FINISH: HOT DIP GALVANIZED  
 SERVICE LIFE: 75 YEARS
- TYPE 1 - 8X12 W4.5x3.5 MATS
  - TYPE 2 - 8x21 W7.0x4.0 MATS
  - TYPE 3 - 8x21 W9.5x4.0 MATS
  - TYPE 3 & 2 - 8x21 W9.5x4.0 MATS W/ 8X21 W7.0x4.0 INTERMEDIATE FLAT MAT

**MSE WALL SITE 1 - ELEVATION VIEW**  
 SCALE: 1" = 10'

THE DESIGN CONTAINED ON THESE DRAWINGS IS BASED ON INFORMATION PROVIDED BY THE OWNER. ON THE BASIS OF THIS INFORMATION, THE HILFIKER COMPANY HAS DESIGNED, AND IS RESPONSIBLE FOR THE INTERNAL STABILITY OF THE STRUCTURE ONLY. EXTERNAL STABILITY, INCLUDING FOUNDATION AND SLOPE STABILITY, IS THE RESPONSIBILITY OF THE OWNER.

REV. NO.	DATE	BY	DESCRIPTION
	10-25-19	KLC	Initial .pdf Release

**HILFIKER RETAINING WALLS**

1902 Hilfiker Lane  
 Eureka, CA 95503-5711  
 TOLL-FREE 800.762.8962  
 PH 707.443.5093 FAX 707.443.2891  
 WEB SITE www.hilfiker.com E-MAIL info@hilfiker.com

**CESARETTI**  
 Engineered Solutions  
 CIVIL ENGINEERING SPECIALISTS

P.O. Box 132  
 Fortuna, CA 95540  
 Phone (707) 725-CESR  
 (707) 498-7193  
 CesarettiEngineered.com  
 KCesaretti@att.net

CA ERFO ANGELES NF 3N17(2) SANTA CLARA DIVIDE  
**MSE WELDED WIRE WALL**  
 SITE 1 - ELEVATION VIEW

HW 190814AW

PROJECT	19-055
DATE	10-25-19
DESIGN	KLC
DRAWN	KLC

SHT **2** OF 6

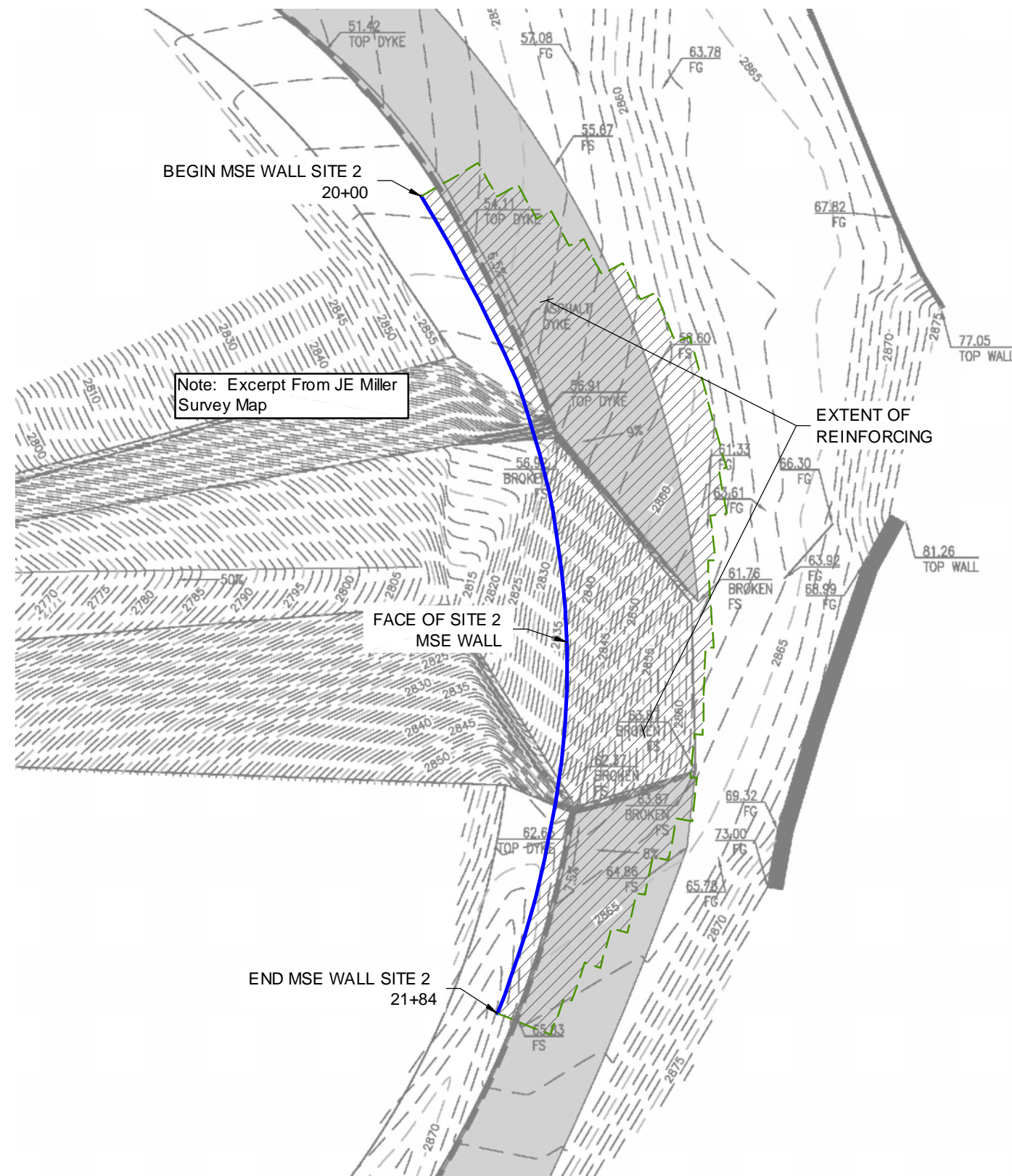

Note: Excerpt From JE Miller Survey Map

**SITE 2 - PLAN VIEW**  
 SCALE: 1" = 30'



THE DESIGN CONTAINED ON THESE DRAWINGS IS BASED ON INFORMATION PROVIDED BY THE OWNER. ON THE BASIS OF THIS INFORMATION, THE HILFIKER COMPANY HAS DESIGNED, AND IS RESPONSIBLE FOR THE INTERNAL STABILITY OF THE STRUCTURE ONLY. EXTERNAL STABILITY, INCLUDING FOUNDATION AND SLOPE STABILITY, IS THE RESPONSIBILITY OF THE OWNER.

REV. NO.	DATE	BY	DESCRIPTION
	10-25-19	KLC	Initial .pdf Release

**HILFIKER RETAINING WALLS**

1902 HilfiKER Lane  
 Eureka, CA 95503-5711  
 TOLL-FREE 800.762.8962  
 PH 707.443.5093 FAX 707.443.2891  
 WEB SITE www.hilfiKER.com E-MAIL info@hilfiKER.com

**CESARETTI**  
 Engineered Solutions  
 CIVIL ENGINEERING SPECIALISTS

P.O. Box 132  
 Fortuna, CA 95540  
 Phone (707) 725-CESR  
 (707) 498-7193  
 CesarettiEngineered.com  
 KCesaretti@att.net

CA ERFO ANGELES NF 3N17(2) SANTA CLARA DIVIDE  
**MSE WELDED WIRE WALL**  
**SITE 2 - PLAN VIEW**

HW 190814AW

PROJECT	19-055
DATE	10-25-19
DESIGN	KLC
DRAWN	KLC
SHT	<b>3</b> OF 6

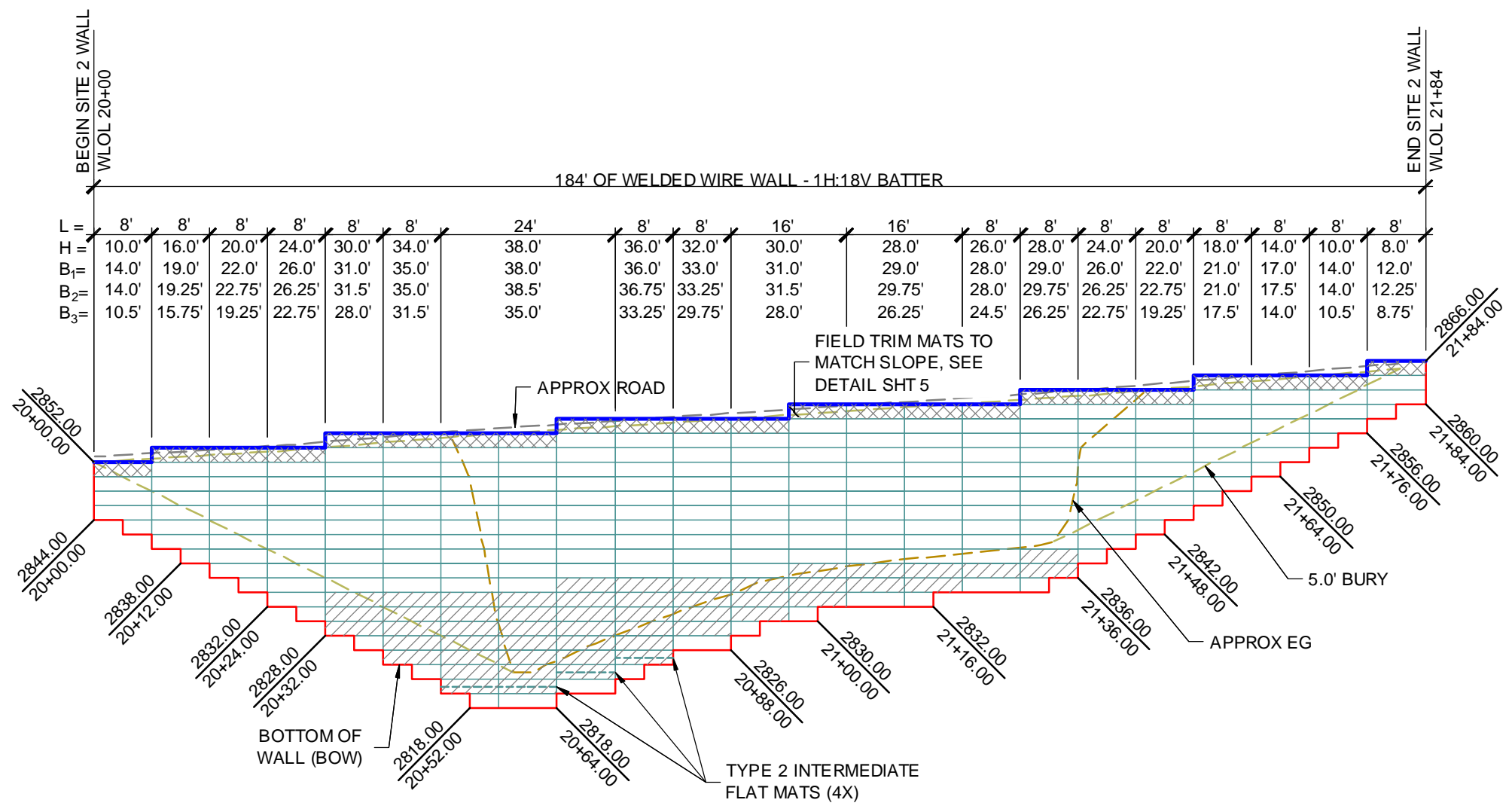

SITE 2 - WELDED WIRE WALL PARAMETERS			
Height of Wall (H) ft	Length of Cap & Prongless Mats (B <sub>1</sub> ) ft	Base Length of TOP Std Mat (B <sub>2</sub> ) ft	Base Length of Lower Std Mats (B <sub>3</sub> ) ft
≤ 8'	12.0'	12.25'	8.75'
10'	14.0'	14.0'	10.5'
14'	17.0'	17.0'	14.0'
16'	19.0'	19.25'	15.75'
18'	21.0'	21.0'	17.5'
20'	22.0'	22.75'	19.25'
24'	26.0'	26.25'	22.75'
26'	28.0'	28.0'	24.5'
28'	29.0'	29.75'	26.25'
30'	31.0'	31.5'	28.0'
32'	33.0'	33.25'	29.25'
34'	35.0'	35.0'	31.5'
36'	36.0'	36.75'	33.25'
38'	38.0'	38.5'	35.0'

Cap & Top Mats (B<sub>1</sub>) are: 8x12 W4.5x3.5 WWR (Type 1)  
 Standard Mats (B<sub>2</sub>) are: 8x21 W7.0x4.0 WWR (Type 2)  
                                   8x21 W9.5x4.0 WWR (Type 3)  
 Finish: Hot Dip Galvanized - 75 Year Service Life

**MSE WALL SITE 2 - ELEVATION VIEW**  
 SCALE: 1" = 20'

- WALL WIRE TYPE LEGEND**
- FINISH: HOT DIP GALVANIZED  
 SERVICE LIFE: 75 YEARS
- TYPE 1 - 8X12 W4.5x3.5 MATS
  - TYPE 2 - 8x21 W7.0x4.0 MATS
  - TYPE 3 - 8x21 W9.5x4.0 MATS
  - TYPE 3 & 2 - 8x21 W9.5x4.0 MATS  
 W/ 8X21 W7.0x4.0 INTERMEDIATE FLAT MAT

THE DESIGN CONTAINED ON THESE DRAWINGS IS BASED ON INFORMATION PROVIDED BY THE OWNER. ON THE BASIS OF THIS INFORMATION, THE HILFIKER COMPANY HAS DESIGNED, AND IS RESPONSIBLE FOR THE INTERNAL STABILITY OF THE STRUCTURE ONLY. EXTERNAL STABILITY, INCLUDING FOUNDATION AND SLOPE STABILITY, IS THE RESPONSIBILITY OF THE OWNER.

REV. NO.	DATE	BY	DESCRIPTION
	10-25-19	KLC	Initial .pdf Release

**HILFIKER RETAINING WALLS**

1902 Hilfiker Lane  
 Eureka, CA 95503-5711  
 TOLL-FREE 800.762.8962  
 PH 707.443.5093 FAX 707.443.2891  
 WEB SITE www.hilfiker.com E-MAIL info@hilfiker.com

**1902**  
 QUALITY WALLS

**CESARETTI**  
 Engineered Solutions  
 CIVIL ENGINEERING SPECIALISTS

P.O. Box 132  
 Fortuna, CA 95540  
 Phone (707) 725-CESR  
 (707) 498-7193  
 CesarettiEngineered.com  
 KCesaretti@att.net

CA ERFO ANGELES NF 3N17(2) SANTA CLARA DIVIDE  
**MSE WELDED WIRE WALL**  
 SITE 2 - ELEVATION VIEW

HW 190814AW

PROJECT	19-055
DATE	10-25-19
DESIGN	KLC
DRAWN	KLC

SHT **4** OF 6

THE DESIGN CONTAINED ON THESE DRAWINGS IS BASED ON INFORMATION PROVIDED BY THE OWNER. ON THE BASIS OF THIS INFORMATION, THE HILFIKER COMPANY HAS DESIGNED, AND IS RESPONSIBLE FOR THE INTERNAL STABILITY OF THE STRUCTURE ONLY. EXTERNAL STABILITY, INCLUDING FOUNDATION AND SLOPE STABILITY, IS THE RESPONSIBILITY OF THE OWNER.

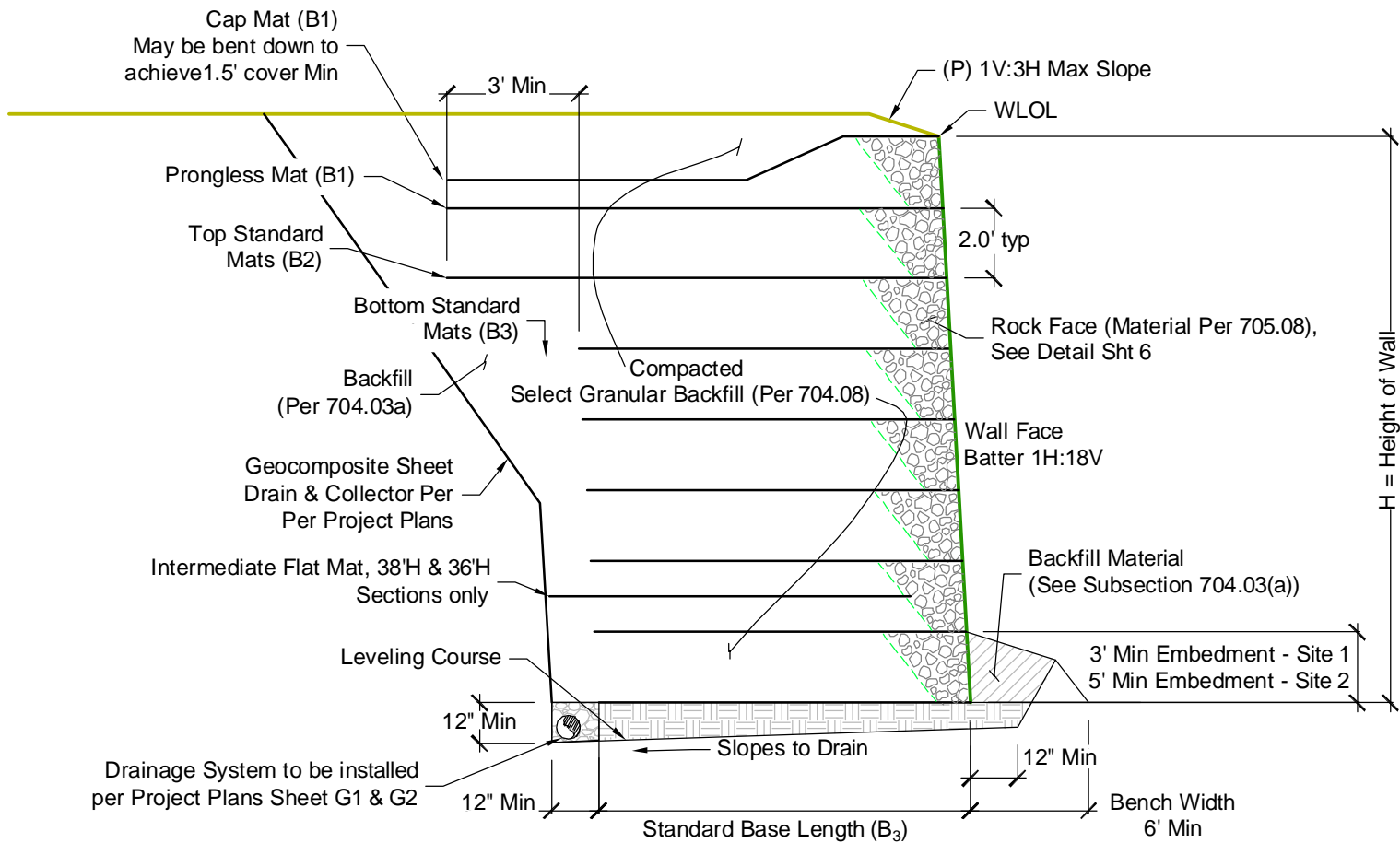

**CROSS SECTION, TYP**

SCALE: 1" = 5'

AT THE UPPER SURFACE OF THE CULVERT, CUT THE TRANSVERSE WIRES ONLY. BEND AND LIFT THE LONGITUDINAL WIRES IN THE BASE OF THE MAT TO FIT AGAINST THE SIDE OF THE CULVERT

AT THE LOWER SURFACE OF THE CULVERT, CUT THE TRANSVERSE WIRES ONLY IN THE MAT FACE. BEND THE LONGITUDINAL WIRES BACK TO FIT AGAINST THE CURVE OF THE CULVERT

NOTE: BACKING MATS AND FILTER FABRIC (NOT SHOWN) ARE TO BE CUT OFF FLUSH WITH THE SIDES OF THE CULVERT

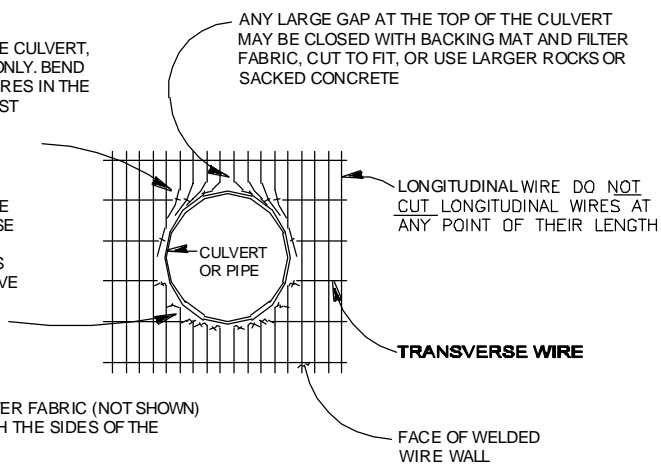

**ELEVATION CULVERT THRU WALL FACE**  
NOT TO SCALE

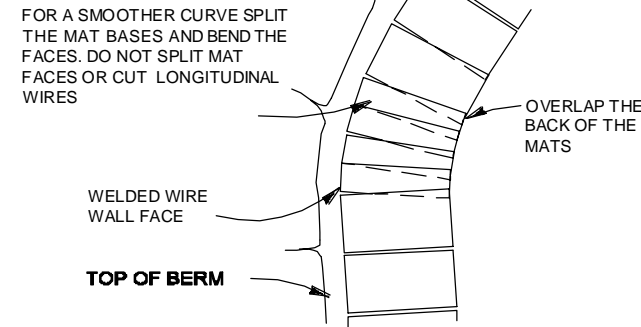

**PLAN VIEW CONVEX CURVE**  
NOT TO SCALE

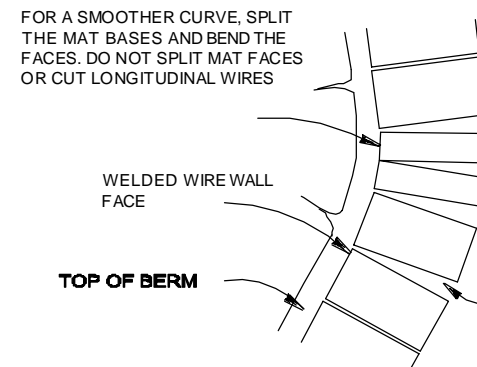

**PLAN VIEW CONCAVE CURVE**  
NOT TO SCALE

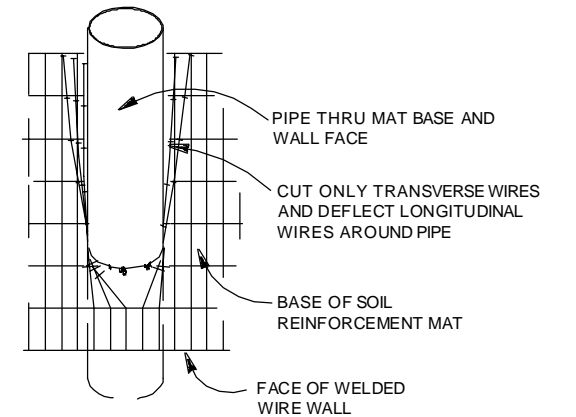

**PLAN VIEW PIPE OR SLEEVE PENETRATION**  
NOT TO SCALE

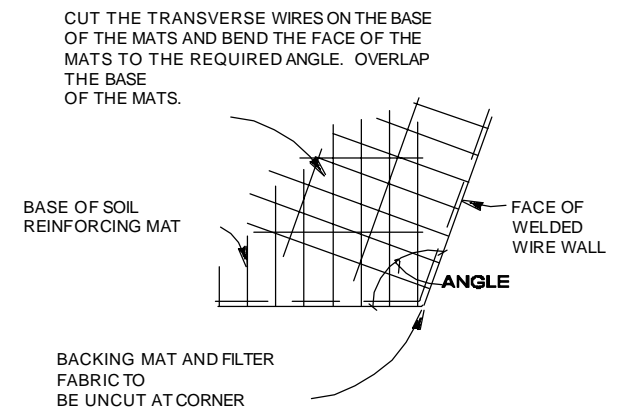

**PLAN VIEW OBTUSE CONVEX ANGLE**  
NOT TO SCALE

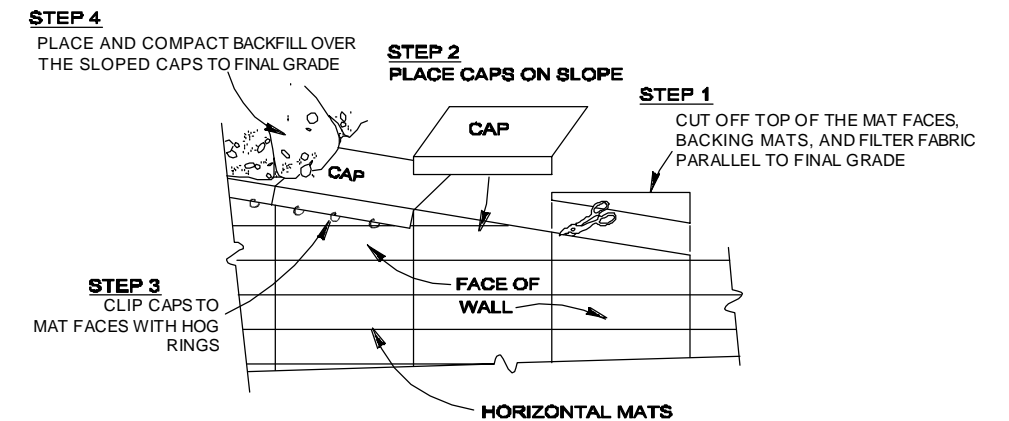

**PICTORIAL ELEVATION SLOPED CAP MAT DETAIL**  
NOT TO SCALE

REV. NO.	DATE	BY	DESCRIPTION
	10-25-19	KLC	Initial .pdf Release

**HILFIKER RETAINING WALLS**

1902 Hilfiker Lane  
Eureka, CA 95503-5711  
TOLL-FREE 800.762.8962  
PH 707.443.5093 FAX 707.443.2891  
WEB SITE www.hilfiker.com E-MAIL info@hilfiker.com

**CESARETTI**  
Engineered  
Solutions  
CIVIL ENGINEERING SPECIALISTS

P.O. Box 132  
Fortuna, CA 95540  
Phone (707) 725-CESR  
(707) 498-7193  
CesarettiEngineered.com  
KCesaretti@att.net

CA ERFO ANGELES NF 3N17(2) SANTA CLARA  
DIVIDE  
MSE WELDED WIRE WALL  
CROSS SECTION & DETAILS

HW 190814AW

PROJECT	19-055
DATE	10-25-19
DESIGN	KLC
DRAWN	KLC
SHT	5 OF 6

**STEP 1**

PLACE THE FIRST COURSE OF SOIL REINFORCEMENT MATS ON PREPARED FOUNDATION.

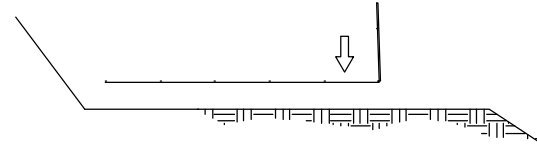

**STEP 2**

PLACE THE BACKING MAT AGAINST THE INSIDE FACE OF THE SOIL REINFORCEMENT MAT. CLIP THE SECOND-TO-TOP TRANSVERSE WIRE ON THE BACKING MAT TO THE TOP TRANSVERSE WIRE ON THE SOIL REINFORCEMENT MAT.

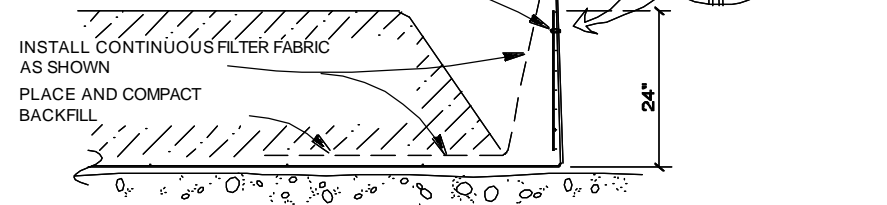

**STEP 3**

BRING THE FILTER FABRIC OVER THE FRONT AND TOP OF THE BACKFILL AS SHOWN. PLACE THE ROCK IN THE FACE OF THE WALL. LEAVE A VOID AS SHOWN.

PLACE THE SECOND COURSE OF SOIL REINFORCEMENT MATS WITH THE BASE LONGITUDINAL WIRES RESTING ON THE TOP TRANSVERSE WIRE OF THE BACKING MAT BELOW. SLIDE THE SOIL REINFORCEMENT MAT INTO ALIGNMENT.

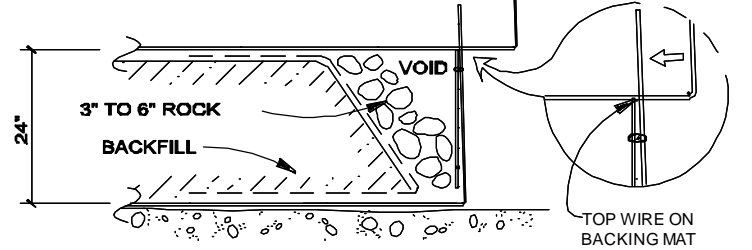

**STEP 4**

HOOK THE BOTTOM TRANSVERSE WIRE OF THE BACKING MAT OVER THE VERTICAL PRONGS ON THE LOWER MAT. ROTATE THE BACKING MAT TO VERTICAL AND CLIP THE SECOND-TO-TOP TRANSVERSE WIRE ON THE BACKING MAT TO THE TOP WIRE ON THE SOIL REINFORCEMENT MAT.

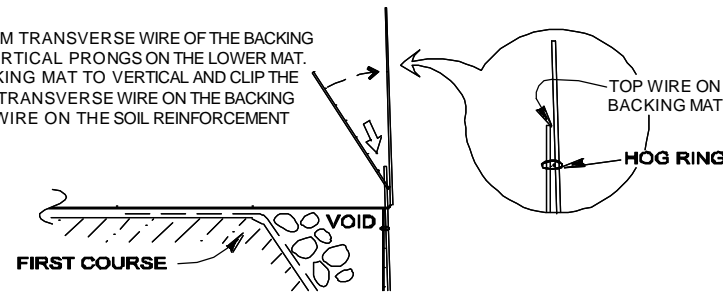

**STEP 5**

INSTALL THE FILTER FABRIC AS IN STEPS 2 AND 3. PLACE AND COMPACT THE BACKFILL AND ROCK TO THE BASE ELEVATION OF THE NEXT MAT. REPEAT STEPS 2 THROUGH 5 TO THE TOP LIFT.

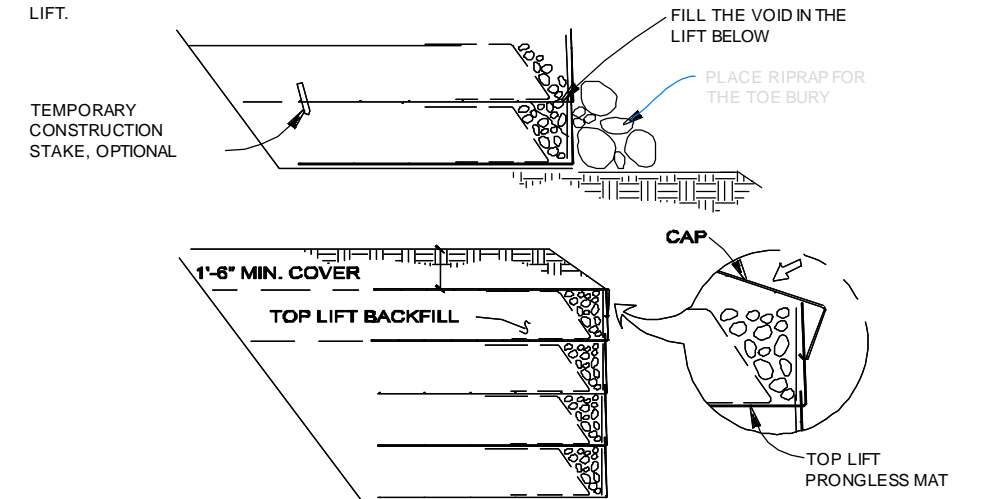

**STEP 6: TOP LIFT**

PLACE THE TOP LIFT PRONGLESS MAT, BACKING MAT AND FILTER FABRIC. PLACE AND COMPACT BACKFILL AND ROCK IN THE TOP LIFT. HOOK THE CAP OVER THE MIDDLE TRANSVERSE WIRE ON THE PRONGLESS MAT, AND ROTATE INTO PLACE. PLACE AND COMPACT COVER OVER TOP MAT TO 1'-6" MINIMUM DEPTH.

**CONSTRUCTION SEQUENCE**

NOT TO SCALE

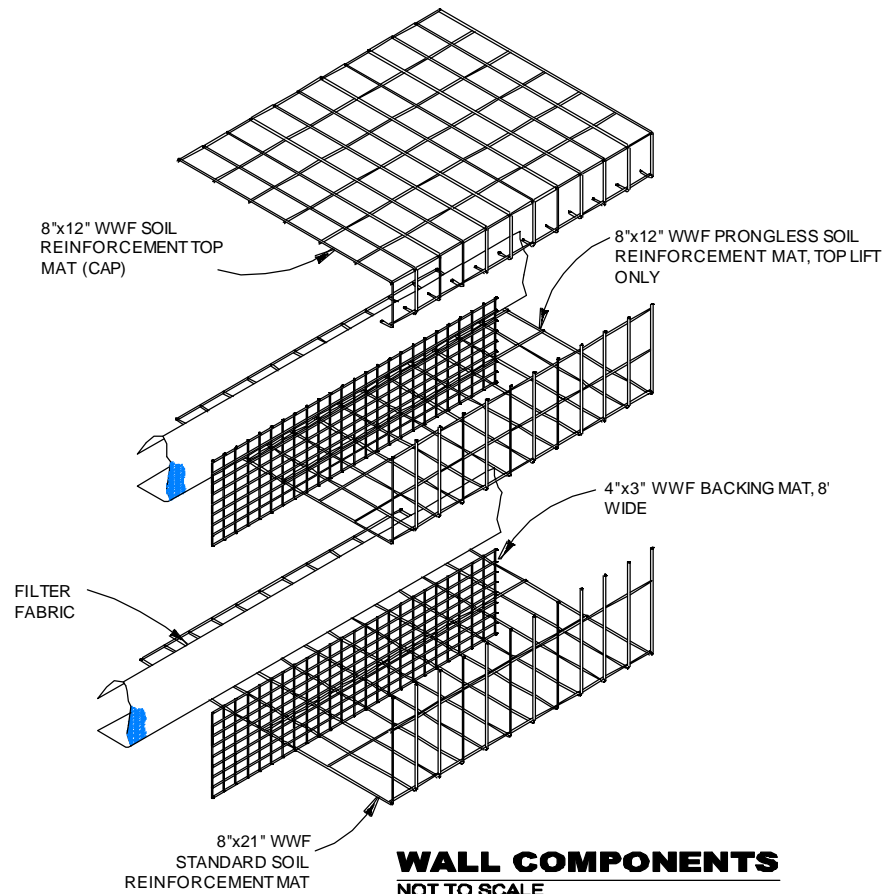

**WALL COMPONENTS**  
NOT TO SCALE

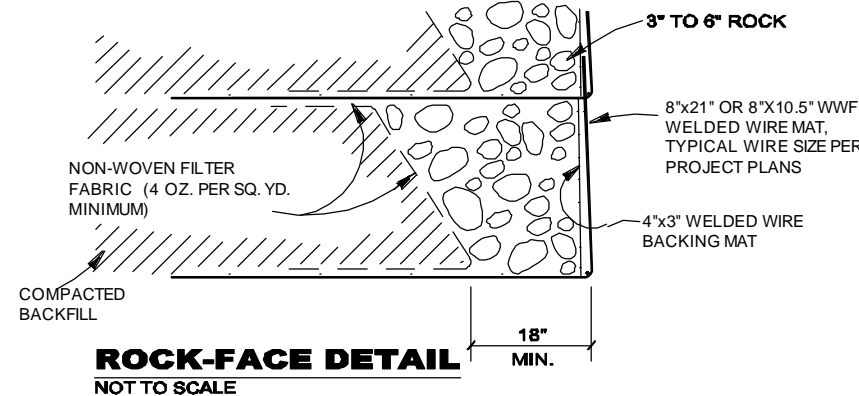

**ROCK-FACE DETAIL**  
NOT TO SCALE

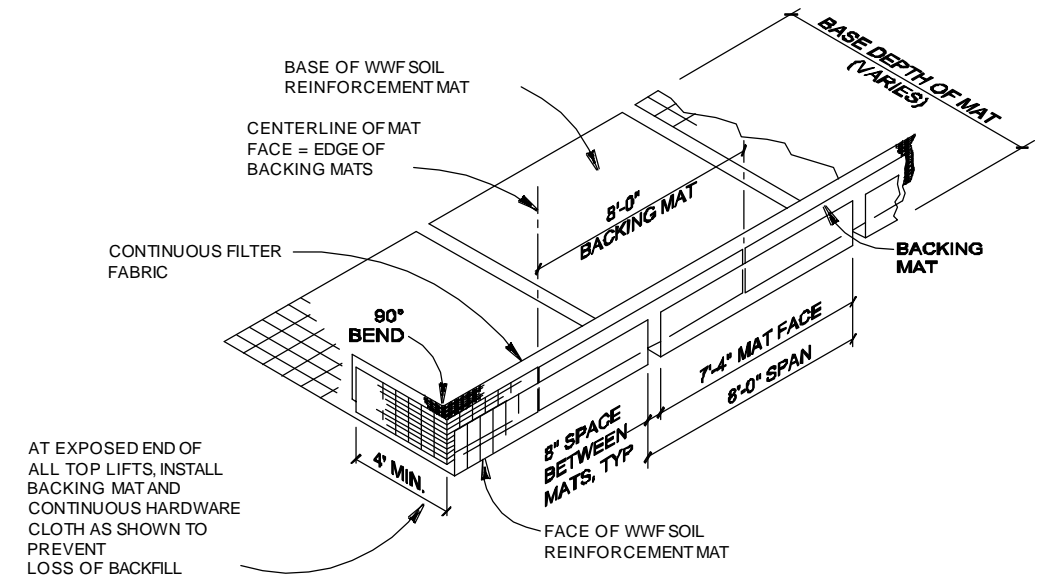

**ISOMETRIC VIEW**  
**WELDED WIRE WALL COMPONENTS WITH RETURN MAT**  
NOT TO SCALE

THE DESIGN CONTAINED ON THESE DRAWINGS IS BASED ON INFORMATION PROVIDED BY THE OWNER. ON THE BASIS OF THIS INFORMATION, THE HILFIKER COMPANY HAS DESIGNED, AND IS RESPONSIBLE FOR THE INTERNAL STABILITY OF THE STRUCTURE ONLY. EXTERNAL STABILITY, INCLUDING FOUNDATION AND SLOPE STABILITY, IS THE RESPONSIBILITY OF THE OWNER.

REV. NO.	DATE	BY	DESCRIPTION
	10-25-19	KLC	Initial .pdf Release

**HILFIKER RETAINING WALLS**

1902 Hilfiker Lane  
Eureka, CA 95503-5711  
TOLL-FREE 800.762.8962  
PH 707.443.5093 FAX 707.443.2891  
WEB SITE www.hilfiker.com E-MAIL info@hilfiker.com

**CESARETTI**  
Engineered  
Solutions  
CIVIL ENGINEERING SPECIALISTS

P.O. Box 132  
Fortuna, CA 95540  
Phone (707) 725-CESR  
(707) 498-7193  
CesarettiEngineered.com  
KCesaretti@att.net

CA ERFO ANGELES NF 3N17(2) SANTA CLARA  
DIVIDE  
MSE WELDED WIRE WALL  
CONSTRUCTION SEQUENCE &  
DETAILS

HW 190814AW

PROJECT	19-055
DATE	10-25-19
DESIGN	KLC
DRAWN	KLC
SHT	6 OF 6