

**VICINITY MAP**

NOT TO SCALE

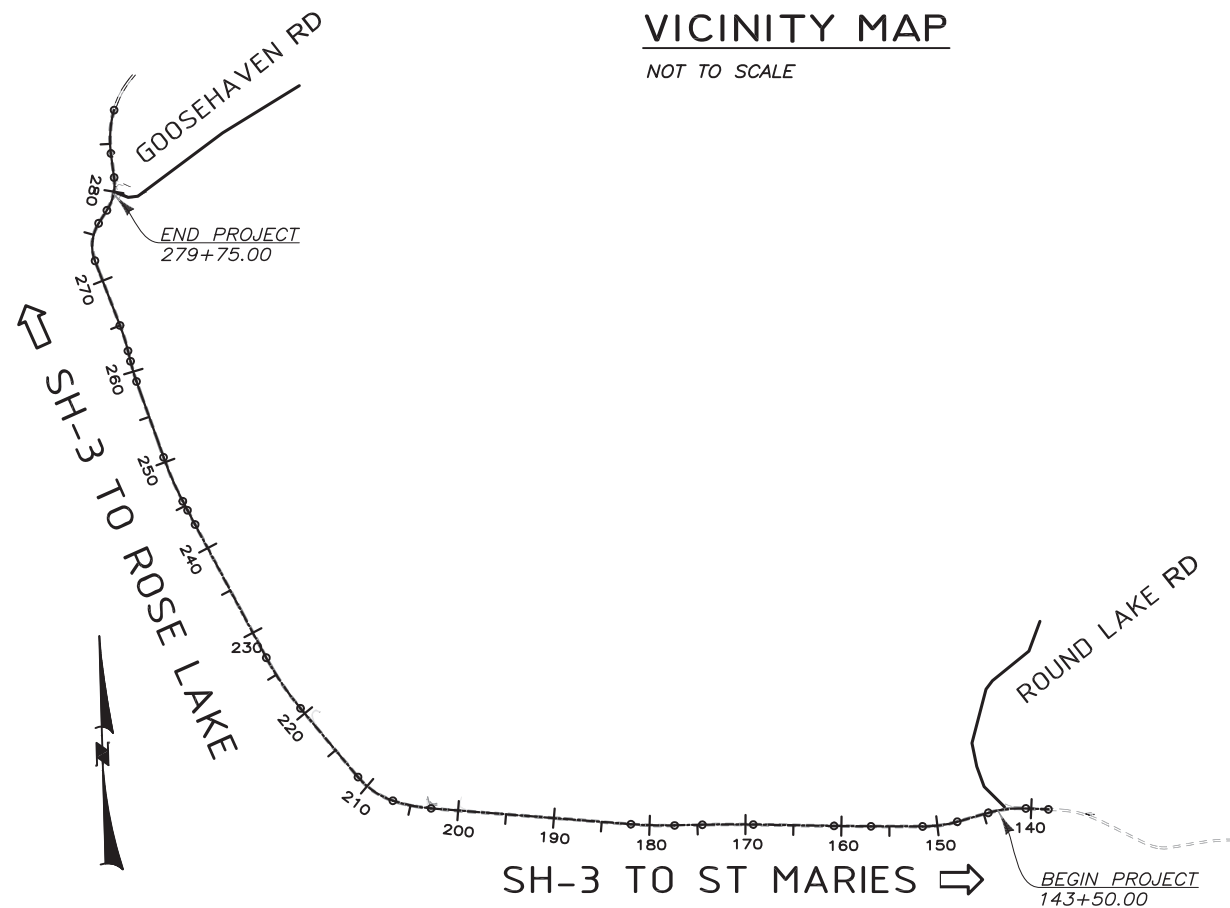

SH-3 TO ST MARIES ⇨

**KEY PLAN**

GRAPHIC SCALE

**GENERAL NOTES**

- DESIGN IS BASED ON THE ASSUMPTION THAT BACKFILL WITHIN THE REINFORCED SOIL MASS, METHODS OF CONSTRUCTION AND THE QUALITY OF MATERIALS CONFORM TO THE REQUIREMENTS OF HILFIKER RETAINING WALLS.
- ASSUMED MATERIAL CHARACTERISTICS:  
 WALL BACKFILL – AGGREGATE (CONTRACTOR TO VERIFY BY TEST):  
 TOTAL UNIT WEIGHT: 125 PCF  
 INTERNAL FRICTION ANGLE: 34° (ASTM D3080)  
 COHESION: 0 PSF  
 WALL BACKFILL – AGGREGATE/GEOFOAM COMPOSITE  
 TOTAL UNIT WEIGHT: 40 PCF  
 INTERNAL FRICTION ANGLE: 34° (ASTM D3080)  
 COHESION: 0 PSF  
 RETAINED BACKFILL:  
 TOTAL UNIT WEIGHT: 101 PCF  
 INTERNAL FRICTION ANGLE: 33°  
 COHESION: 0 PSF  
 FOUNDATION SOILS:  
 TOTAL UNIT WEIGHT: 103 PCF  
 INTERNAL FRICTION ANGLE: 29°  
 COHESION: 25 PSF  
  
 SEISMIC ACCELERATION: 0.098 PGA (SITE CLASS B),  $A_s=0.25g$ ,  $0.5A_s=0.12g$   
  
 IF ACTUAL MATERIAL CHARACTERISTICS, GRADES OR DIMENSIONS OF SOIL MATERIALS DIFFER FROM THOSE LISTED ABOVE OR SHOWN ON THE PLANS, HILFIKER RETAINING WALLS SHALL BE NOTIFIED TO EVALUATE THE NEED TO REDESIGN.
- THE DESIGN REQUIRES A NON-SATURATED BACKFILL. SURFACE AND SUB-SURFACE DRAINAGE CONTROL MAY BE REQUIRED TO PREVENT SATURATION OF THE BACKFILL OR RELIEVE HYDROSTATIC PRESSURES.
- SURFACE AND INTERNAL DRAINAGE CONTROL SHALL BE AS SPECIFIED IN THE PROJECT PLANS AND SPECIFICATIONS OR AS DIRECTED BY THE OWNER'S ENGINEER. PAYMENT FOR DRAINAGE SHALL BE AS SPECIFIED IN THE PROJECT SPECIFICATIONS.
- SOIL REINFORCEMENTS SHALL BE FABRICATED OF WELDED WIRE FABRIC CONFORMING TO AASHTO M-32 AND M-55 AND SHALL BE GALVANIZED IN ACCORDANCE WITH AASHTO M-111 FOLLOWING FABRICATION.
- THIS DESIGN SUBMITTAL IS BASED ON ASTM A1115 – STANDARD PRACTICE FOR CONSTRUCTION OF MECHANICALLY STABILIZED EARTH WALLS WITH INEXTENSIBLE SOIL REINFORCEMENT (LATEST APPROVAL).
- THIS IS A PERMANENT MSE WALL DESIGNED FOR 75 YEARS OF SERVICE. THE OWNER IS THE IDAHO TRANSPORTATION DEPARTMENT.
- AMERICAN GEOTECHNICS IS NOT THE OWNER'S "ENGINEER OF RECORD" OR THE OWNER'S "GEOTECHNICAL ENGINEER" OR THE OWNER'S "HYDRAULIC ENGINEER," AS DESCRIBED IN ASTM A1115. THE OWNER IS RESPONSIBLE FOR THE FOLLOWING:  
 A. EVALUATING GLOBAL STABILITY AND UPLIFT (BOUNCY) RESISTANCE  
 B. ESTABLISHING FOUNDATION BEARING RESISTANCE DESIGN CRITERIA  
 C. IMPLEMENTING AN ADEQUATE QUALITY CONTROL PROGRAM  
 D. UPLIFT (BOUYANCY) RESISTANCE CALCULATIONS
- HILFIKER RETAINING WALLS, INC (800-762-8962) IS THE "WALL SUPPLIER" WHOSE SYSTEM AND COMPONENTS ARE THE SOLE BASIS OF THIS SUBMITTAL.
- AMERICAN GEOTECHNICS (208-658-8700) IS THE "WALL DESIGN ENGINEER," AS DESCRIBED IN ASTM A1115. AMERICAN GEOTECHNICS HAS SPECIFIED THE TYPE(S), SIZES, AND LOCATIONS OF BURIED REINFORCEMENTS FOR THIS SUBMITTAL.
- THE ENGINEER OF RECORD ADMINISTERS THE OWNER'S REQUIREMENTS FOR THE LONG-TERM STABILITY OF THE MSE WALL (MSEW), INCLUDING:  
 A. FOUNDATION PREPARATION REQUIREMENTS OF THE GEOTECHNICAL ENGINEER  
 B. INTERNAL DRAINAGE SYSTEMS AND COMPONENTS TO ENSURE NON-SATURATED BACKFILL.  
 C. SCOUR COUNTERMEASURES ALONG THE TOE  
 D. EROSION COUNTERMEASURES AT THE ENDS  
 E. SURFACE WATER DRAINAGE CONTROLS ABOVE THE WALL  
 F. CONSTRUCTION OF THE SUPPLIED MSEW SYSTEM WITH ALL OF ITS APPURTENANT COMPONENTS  
 G. PROTECTION OF REINFORCEMENT, SUCH THAT UNAUTHORIZED CUTTING OF WIRES DOES NOT OCCUR.
- HEAVY CRANES OR SIMILAR HEAVY LOADS SHALL NOT BE PLACED WITHIN TWENTY FEET OF THE MSE WALL FACE. DO NOT STOCKPILE SOIL ON THE MSE WALLS.
- IF THERE ARE BOTTOM OF WALL ELEVATION DISCREPANCIES, NOTIFY OUR OFFICE SO THAT REDESIGN CAN BE CONSIDERED.

03584 - SH-3, Goosehaven Rd. I PREP 2-4-2022.dwg  
2/4/2022 10:54 AM

THE DESIGN CONTAINED ON THESE DRAWINGS IS BASED ON INFORMATION PROVIDED BY THE OWNER. ON THE BASIS OF THIS INFORMATION, THE HILFIKER COMPANY HAS DESIGNED, AND IS RESPONSIBLE FOR THE INTERNAL STABILITY OF THE STRUCTURE ONLY. EXTERNAL STABILITY, INCLUDING FOUNDATION AND SLOPE STABILITY, IS THE RESPONSIBILITY OF THE OWNER.

REV.	DATE	BY	DESCRIPTION	CADD:
0	12/30/2021	RGV	ISSUED FOR OWNER REVIEW	RGV
1	2/4/2022	RGV	ISSUED FOR OWNER REVIEW	DESIGNED: RGV
			IN RESPONSE TO COMMENTS	CHECKED: SGC

**HILFIKER RETAINING WALLS**

1902 HilfiKER Lane  
Eureka, CA 95503-5711  
TOLL-FREE 800.762.8962  
PH 707.443.5093 FAX 707.443.2891  
WEB SITE www.hilfiKER.com EMAIL info@hilfiKER.com

**AMERICAN GEOTECHNICS**

American Geotechnics  
5260 Chinden Blvd.  
Boise, ID 83714  
(208) 658-8700  
Fax: (208) 658-8703

KEY PLAN & DESIGN NOTES	
WW WALL	
SH-3, GOOSEHAVEN RD. TO ROUND LAKE RD.	
ITD	BENEWAH COUNTY, ID

DWG DATE:	4 FEB 2022
HRW NO.:	210714AW
SHEET	1
OF	61

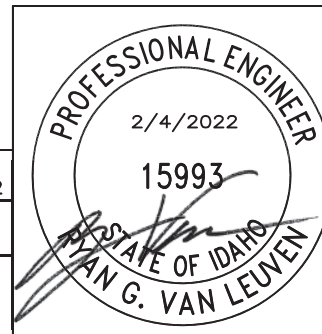

# WELDED WIRE WALL SUPPLIED QUANTITIES

SUPPLIED REINFORCEMENT QUANTITIES			
BASE DEPTH	CAP MAT W7XW3.5 (8"X12")	PRONGLESS MAT W7XW3.5 (8"X12")	STANDARD MAT W4.5XW4 (8"X21")
23'	60	60	
22.75'			60
22'	92	92	
21'			92
19'	1,539	1,539	
18'	4	4	
19.25'			1,539
17.5'			4
15.75'			1,693
10.5'			3,379

TOTAL WALL FACE SUPPLIED	135,392 SF
BACKING MATS (2'-0" HIGH)	8,558 EA
HOG RINGS	203,100 EA
PLIERS	43 EA

03584 - SHEET 3 - GOOSEHAVEN RD. JT PREP 2-28-2022.dwg

2/28/2022 11:11 AM

THE DESIGN CONTAINED ON THESE DRAWINGS IS BASED ON INFORMATION PROVIDED BY THE OWNER. ON THE BASIS OF THIS INFORMATION, THE HILFIKER COMPANY HAS DESIGNED, AND IS RESPONSIBLE FOR THE INTERNAL STABILITY OF THE STRUCTURE ONLY. EXTERNAL STABILITY, INCLUDING FOUNDATION AND SLOPE STABILITY, IS THE RESPONSIBILITY OF THE OWNER.

REV.	DATE	BY	DESCRIPTION
0	12/30/2021	RGV	ISSUED FOR OWNER REVIEW
1	2/4/2022	RGV	ISSUED FOR OWNER REVIEW IN RESPONSE TO COMMENTS
2	2/28/2022	RGV	ISSUED FOR OWNER REVIEW IN RESPONSE TO COMMENTS

CADD:  
RGV  
  
DESIGNED:  
RGV  
  
CHECKED:  
SGC

## HILFIKER RETAINING WALLS



1902 Hilfiker Lane  
Eureka, CA 95503-5711  
TOLL FREE 800.762.8962  
PH 707.443.5093 FAX 707.443.2891  
WEBSITE www.hilfiker.com E-MAIL info@hilfiker.com



American Geotechnics  
5260 Chinden Blvd.  
Boise, ID 83714  
(208) 658-8700  
Fax: (208) 658-8703

QUANTITIES	
WW WALL	ITD
SH-3, GOOSEHAVEN RD. TO ROUND LAKE RD.	BENEWAH COUNTY, ID

DWG DATE: 28 FEB 2022
HRW NO.: 210714AW
SHEET 2 OF 61



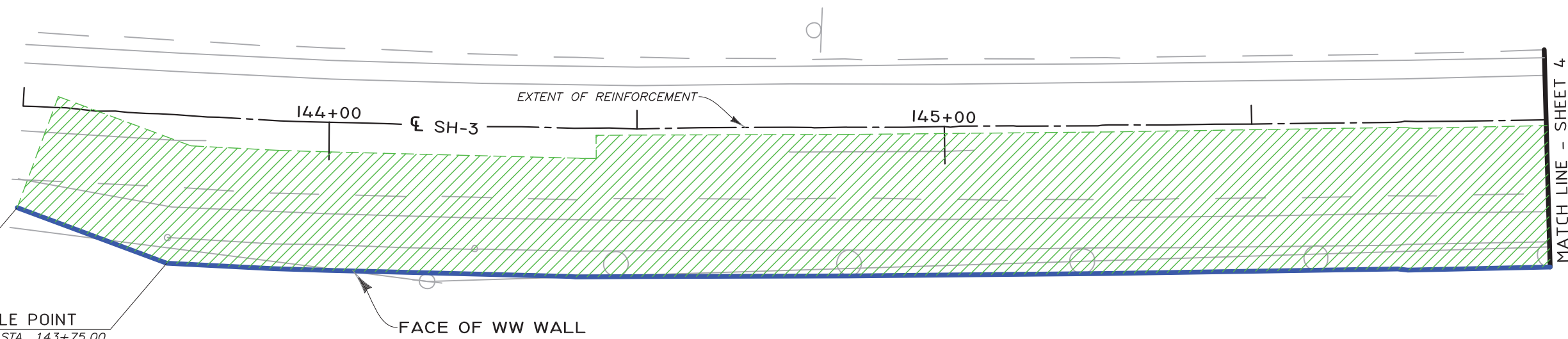
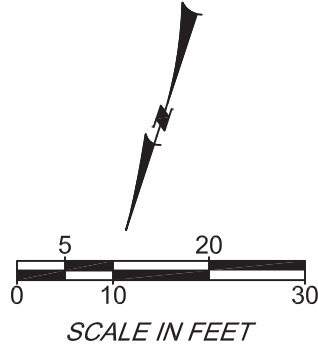

**PLAN**  
GRAPHIC SCALE

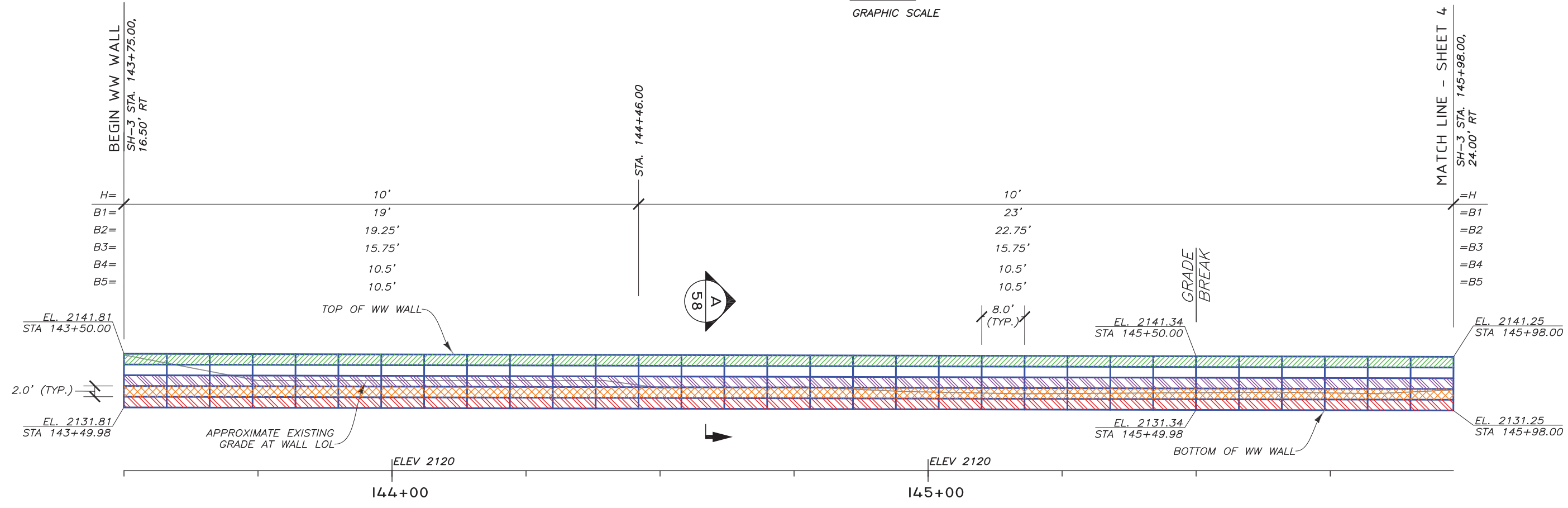

**DEVELOPED ELEVATION - (FRONT FACE)**

GRAPHIC SCALE

**LEGEND**

	B1	8"x12", W7xW3.5-HDG	LOL	LAYOUT LINE
	B2	8"x21", W4.5xW4-HDG	H	WALL HEIGHT (BOTTOM MAT TO CAP MAT)
	B3	8"x21", W4.5xW4-HDG (W/GEOFOAM)	B	MAT LENGTH
	B4	8"x21", W4.5xW4-HDG (W/GEOFOAM)	WW	WELDED WIRE
	B5	8"x21", W4.5xW4-HDG		

03584\_S1-3\_Goosehaven\_Rd\_I1\_PREP 2-4-2022.dwg

2/4/2022 10:54 AM

REV.	DATE	BY	DESCRIPTION	CADD:
0	12/30/2021	RGV	ISSUED FOR OWNER REVIEW	RGV
1	2/4/2022	RGV	ISSUED FOR OWNER REVIEW IN RESPONSE TO COMMENTS	RGV
				CHECKED: SGC

**HILFIKER RETAINING WALLS**

1902 HilfiKER Lane  
Eureka, CA 95503-5711  
TOLL-FREE 800.752.8962  
PH 707.443.5093 FAX 707.443.2891  
WEB SITE www.hilfiKER.com EMAIL info@hilfiKER.com

**AMERICAN GEOTECHNICS**

American Geotechnics  
5260 Chinden Blvd.  
Boise, ID 83714  
(208) 658-8700  
Fax: (208) 658-8703

PLAN & ELEVATION  
WW WALL  
SH-3, GOOSEHAVEN RD.  
TO ROUND LAKE RD.  
ITD BENEWAH COUNTY, ID

DWG DATE:	4 FEB 2022
HRW NO.:	210714AW
SHEET	3
OF	61

PROFESSIONAL ENGINEER  
2/4/2022  
15993  
  
RYAN G. VAN LEUVEN  
STATE OF IDAHO

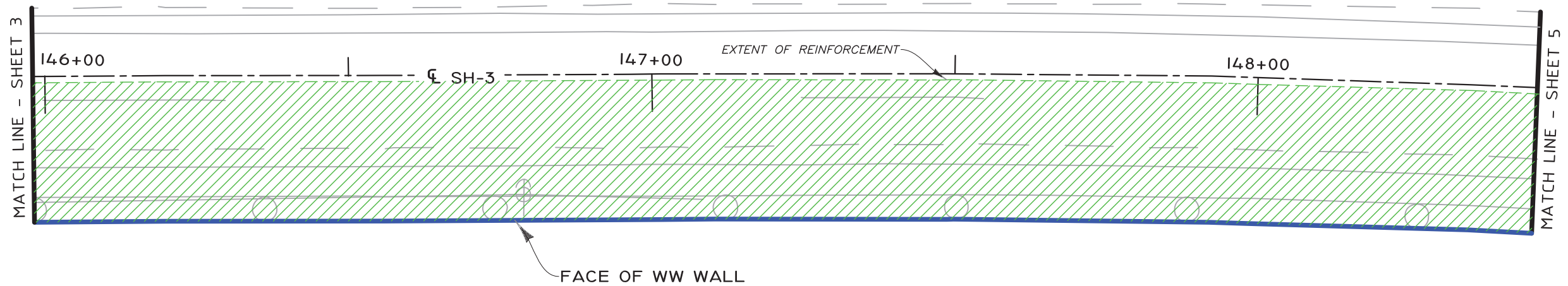
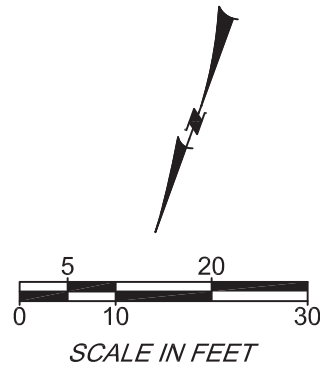

**PLAN**  
GRAPHIC SCALE

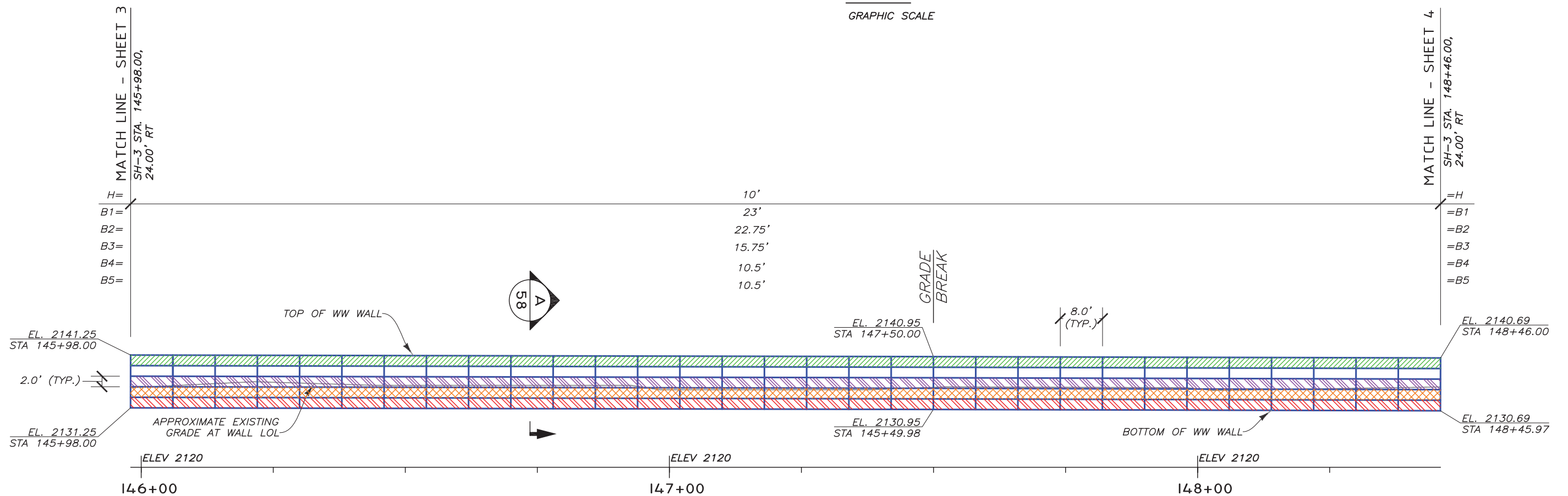

**DEVELOPED ELEVATION - (FRONT FACE)**  
GRAPHIC SCALE

**LEGEND**

	B1	8"x12", W7xW3.5-HDG	LOL	LAYOUT LINE
	B2	8"x21", W4.5xW4-HDG	H	WALL HEIGHT (BOTTOM MAT TO CAP MAT)
	B3	8"x21", W4.5xW4-HDG (W/GEOFOAM)	B	MAT LENGTH
	B4	8"x21", W4.5xW4-HDG (W/GEOFOAM)	WW	WELDED WIRE
	B5	8"x21", W4.5xW4-HDG		

03584-SH-3\_Goosehaven\_Rd\_I\_PREP 2-4-2022.dwg  
2/4/2022 10:54 AM  
RVanLeuven

REV.	DATE	BY	DESCRIPTION	CADD:
0	12/30/2021	RGV	ISSUED FOR OWNER REVIEW	RGV
1	2/4/2022	RGV	ISSUED FOR OWNER REVIEW IN RESPONSE TO COMMENTS	DESIGNED: RGV CHECKED: SGC

**HILFIKER RETAINING WALLS**

1902 Hilfiker Lane  
Eureka, CA 95503-5711  
TOLL-FREE: 800.752.8962  
PH: 707.443.5093 FAX: 707.443.2891  
WEB SITE: www.hilfiker.com E-MAIL: info@hilfiker.com

**AMERICAN GEOTECHNICS**

American Geotechnics  
5260 Chinden Blvd.  
Boise, ID 83714  
(208) 658-8700  
Fax: (208) 658-8703

PLAN & ELEVATION	DWG DATE: 4 FEB 2022
WW WALL	HRW NO.: 210714AW
SH-3, GOOSEHAVEN RD. TO ROUND LAKE RD.	SHEET 4
ITD BENEWAH COUNTY, ID	OF 61

PROFESSIONAL ENGINEER  
2/4/2022  
15993  
N. G. VAN LEUVEN  
STATE OF IDAHO

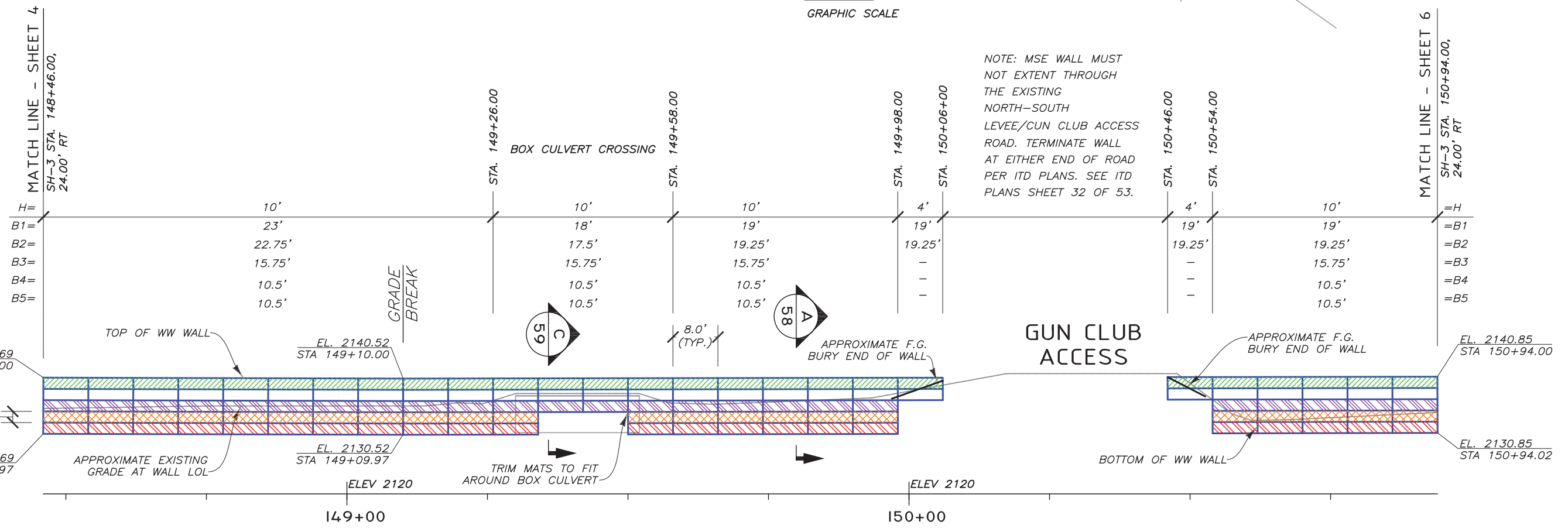
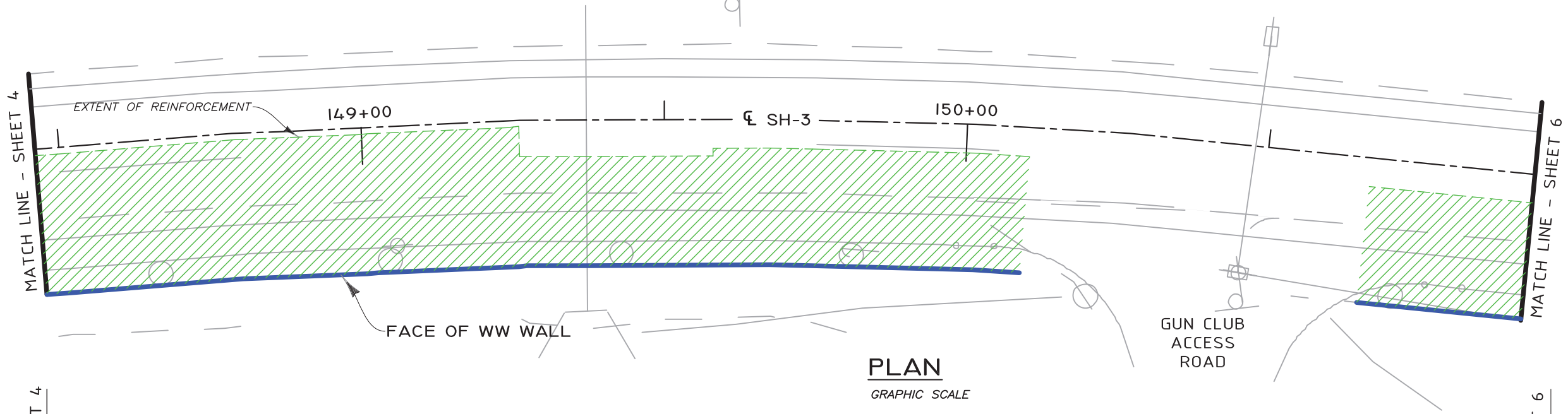
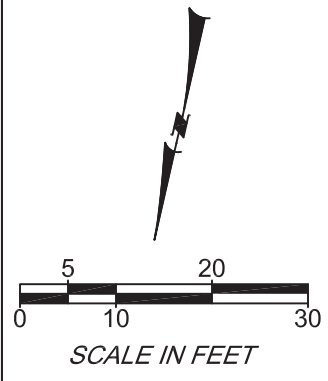

NOTE: MSE WALL MUST NOT EXTENT THROUGH THE EXISTING NORTH-SOUTH LEVEE/CUN CLUB ACCESS ROAD. TERMINATE WALL AT EITHER END OF ROAD PER ITD PLANS. SEE ITD PLANS SHEET 32 OF 53.

**LEGEND**

	B1	8"X12", W7xW3.5-HDG	LOL	LAYOUT LINE
	B2	8"X21", W4.5xW4-HDG	H	WALL HEIGHT (BOTTOM MAT TO CAP MAT)
	B3	8"X21", W4.5xW4-HDG (W/GEOFOAM)	B	MAT LENGTH
	B4	8"X21", W4.5xW4-HDG (W/GEOFOAM)	WW	WELDED WIRE
	B5	8"X21", W4.5xW4-HDG		

**DEVELOPED ELEVATION - (FRONT FACE)**

GRAPHIC SCALE

THE DESIGN CONTAINED ON THESE DRAWINGS IS BASED ON INFORMATION PROVIDED BY THE OWNER. ON THE BASIS OF THIS INFORMATION, THE HILFIKER COMPANY HAS DESIGNED, AND IS RESPONSIBLE FOR THE INTERNAL STABILITY OF THE STRUCTURE ONLY. EXTERNAL STABILITY, INCLUDING FOUNDATION AND SLOPE STABILITY, IS THE RESPONSIBILITY OF THE OWNER.

REV.	DATE	BY	DESCRIPTION
0	12/30/2021	RGV	ISSUED FOR OWNER REVIEW
1	2/4/2022	RGV	ISSUED FOR OWNER REVIEW IN RESPONSE TO COMMENTS
2	2/28/2022	RGV	ISSUED FOR OWNER REVIEW IN RESPONSE TO COMMENTS

CADD:	RGV
DESIGNED:	RGV
CHECKED:	SGC

**HILFIKER RETAINING WALLS**

1902 HilfiKER Lane  
Eureka, CA 95503-5711  
TOLL FREE 800.762.8962  
PH 707.443.5093 FAX 707.443.2891  
WEBSITE www.hilfiKER.com E-MAIL info@hilfiKER.com

**AMERICAN GEOTECHNICS**

American Geotechnics  
5260 Chinden Blvd.  
Boise, ID 83714  
(208) 658-8700  
Fax: (208) 658-8703

PLAN & ELEVATION
WW WALL
SH-3, GOOSEHAVEN RD. TO ROUND LAKE RD.
ITD BENEWAH COUNTY, ID

DWG DATE:	28 FEB 2022
HRW NO.:	210714AW
SHEET	5
OF	61

PROFESSIONAL ENGINEER

2/28/2022

15993

AN G. VAN LEUVEN

03584 - SH-3, Goosehaven Rd., ITD PREP 2-28-2022.dwg  
2/28/2022 11:11 AM  
RVanLeuven

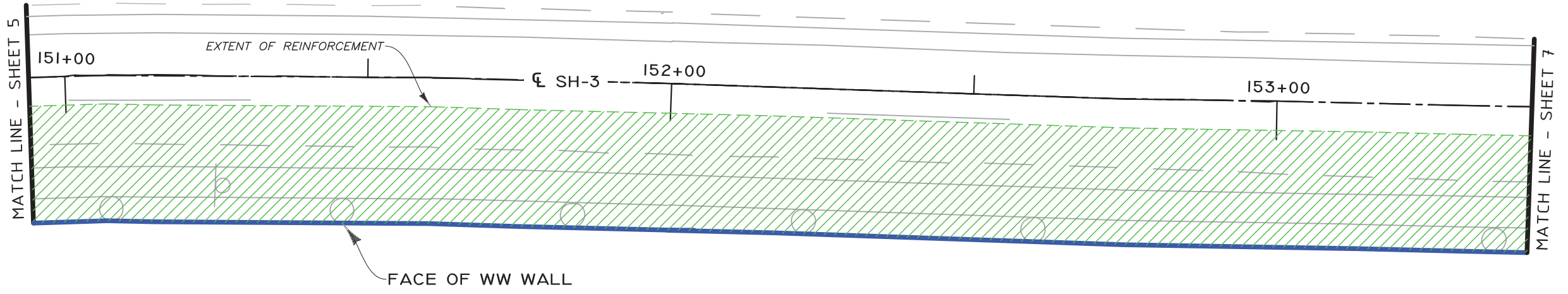
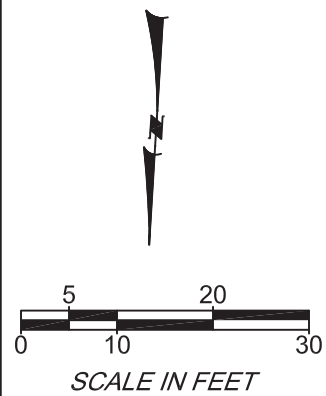

**PLAN**  
GRAPHIC SCALE

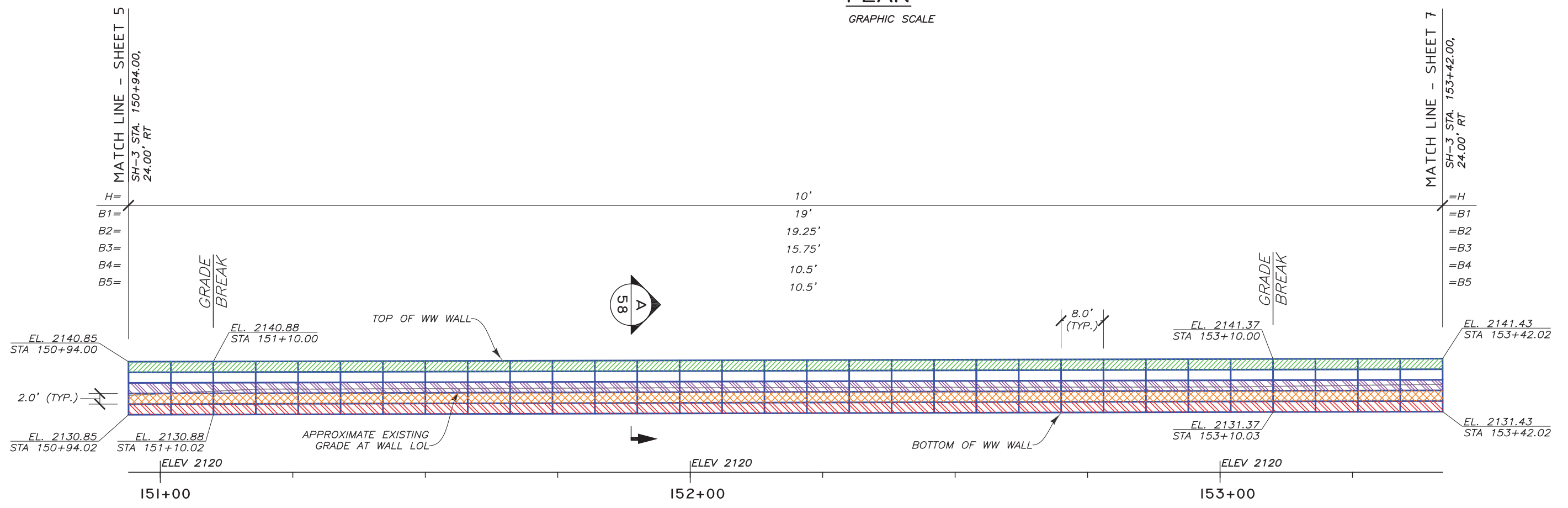

**DEVELOPED ELEVATION - (FRONT FACE)**  
GRAPHIC SCALE

**LEGEND**

	B1	8"X12", W7xW3.5-HDG	LOL	LAYOUT LINE
	B2	8"X21", W4.5xW4-HDG	H	WALL HEIGHT (BOTTOM MAT TO CAP MAT)
	B3	8"X21", W4.5xW4-HDG (W/GEOFOAM)	B	MAT LENGTH
	B4	8"X21", W4.5xW4-HDG (W/GEOFOAM)	WW	WELDED WIRE
	B5	8"X21", W4.5xW4-HDG		

REV.	DATE	BY	DESCRIPTION	CADD:
0	12/30/2021	RGV	ISSUED FOR OWNER REVIEW	RGV
1	2/4/2022	RGV	ISSUED FOR OWNER REVIEW IN RESPONSE TO COMMENTS	RGV
				CHECKED: SGC

**HILFIKER RETAINING WALLS**

1902 Hilfiker Lane  
Eureka, CA 95503-5711  
TOLL-FREE 800.752.8962  
PH 707.443.5093 FAX 707.443.2891  
WEB SITE www.hilfiker.com EMAIL info@hilfiker.com

**AMERICAN GEOTECHNICS**

American Geotechnics  
5260 Chinden Blvd.  
Boise, ID 83714  
(208) 658-8700  
Fax: (208) 658-8703

PLAN & ELEVATION	DWG DATE: 4 FEB 2022
WW WALL	HRW NO.: 210714AW
SH-3, GOOSEHAVEN RD. TO ROUND LAKE RD.	SHEET 6 OF 61
ITD	BENEWAH COUNTY, ID

PROFESSIONAL ENGINEER

2/4/2022

15993

STATE OF IDAHO

G. VAN LEUVEN

03584-SH-3\_Goosehaven\_Rd\_ID\_PREP 2-4-2022.dwg  
2/4/2022 10:54 AM  
RVanLeuven

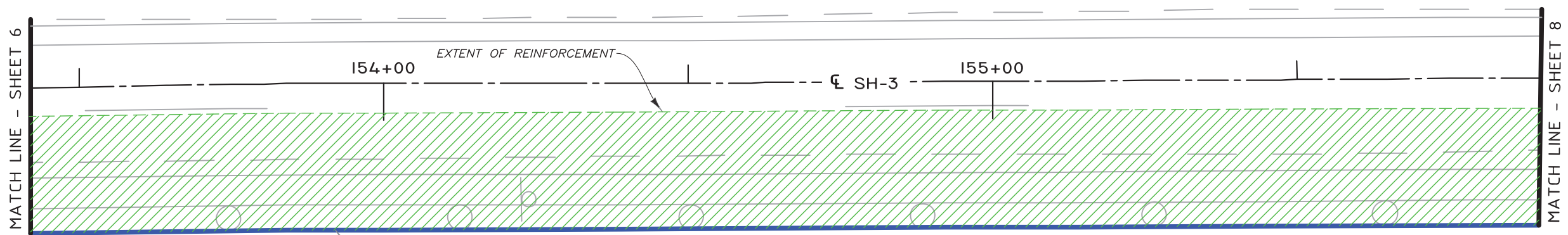
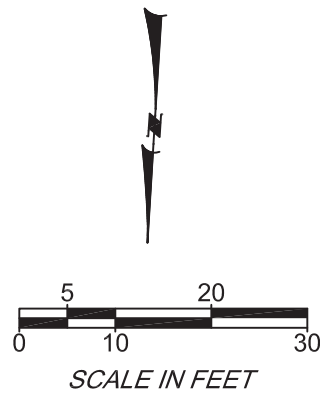

**PLAN**  
GRAPHIC SCALE

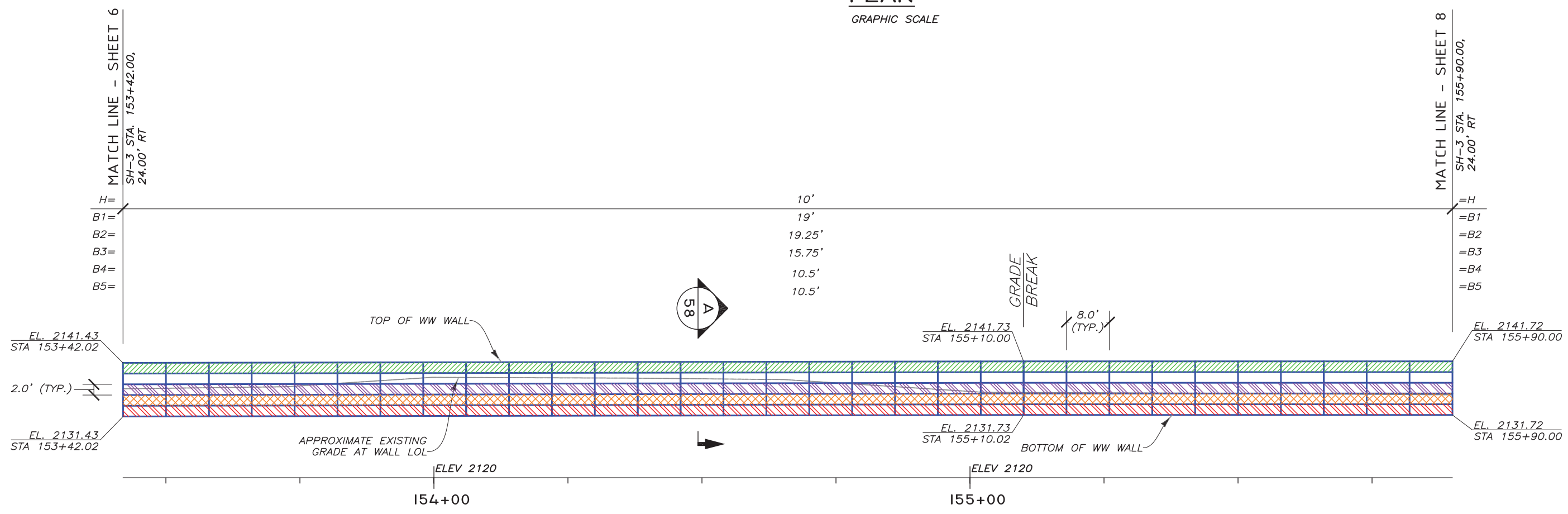

**DEVELOPED ELEVATION - (FRONT FACE)**  
GRAPHIC SCALE

LEGEND			
	B1 8"x12", W7xW3.5-HDG	LOL	LAYOUT LINE
	B2 8"x21", W4.5xW4-HDG	H	WALL HEIGHT (BOTTOM MAT TO CAP MAT)
	B3 8"x21", W4.5xW4-HDG (W/GEOFOAM)	B	MAT LENGTH
	B4 8"x21", W4.5xW4-HDG (W/GEOFOAM)	WW	WELDED WIRE
	B5 8"x21", W4.5xW4-HDG		8x2x3 TRINITY BASKET

REV.	DATE	BY	DESCRIPTION	CADD:
0	12/30/2021	RGV	ISSUED FOR OWNER REVIEW	RGV
1	2/4/2022	RGV	ISSUED FOR OWNER REVIEW IN RESPONSE TO COMMENTS	RGV
				CHECKED: SGC

**HILFIKER RETAINING WALLS**

1902 Hilfiker Lane  
Eureka, CA 95503-5711  
TOLL-FREE 800.752.8962  
PH 707.443.5093 FAX 707.443.2891  
WEB SITE www.hilfiker.com EMAIL info@hilfiker.com

**AMERICAN GEOTECHNICS**

American Geotechnics  
5260 Chinden Blvd.  
Boise, ID 83714  
(208) 658-8700  
Fax: (208) 658-8703

PLAN & ELEVATION	DWG DATE: 4 FEB 2022
WW WALL	HRW NO.: 210714AW
SH-3, GOOSEHAVEN RD. TO ROUND LAKE RD.	SHEET 7 OF 61
ITD BENEWAH COUNTY, ID	

PROFESSIONAL ENGINEER  
2/4/2022  
15993  
  
ALAN G. VAN LEUVEN  
STATE OF IDAHO

03584-SH-3\_Goosehaven\_Rd\_ID\_PREP\_2-4-2022.dwg  
2/4/2022 10:54 AM  
RVanLeuven

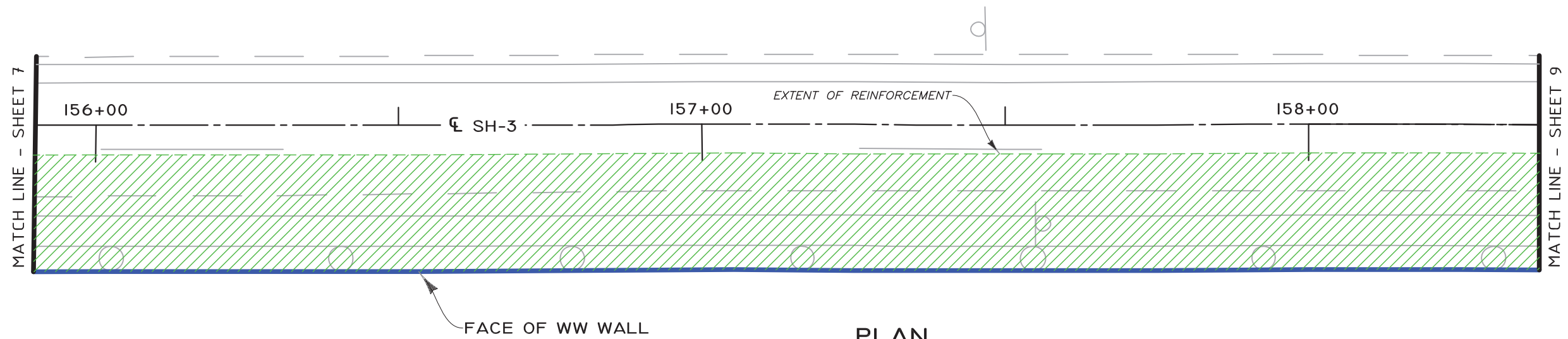
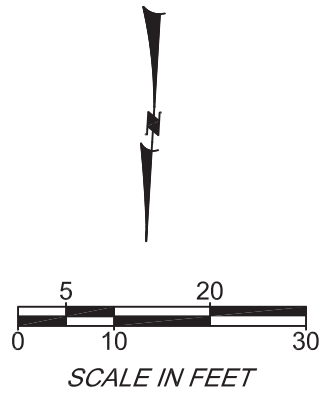

**PLAN**  
GRAPHIC SCALE

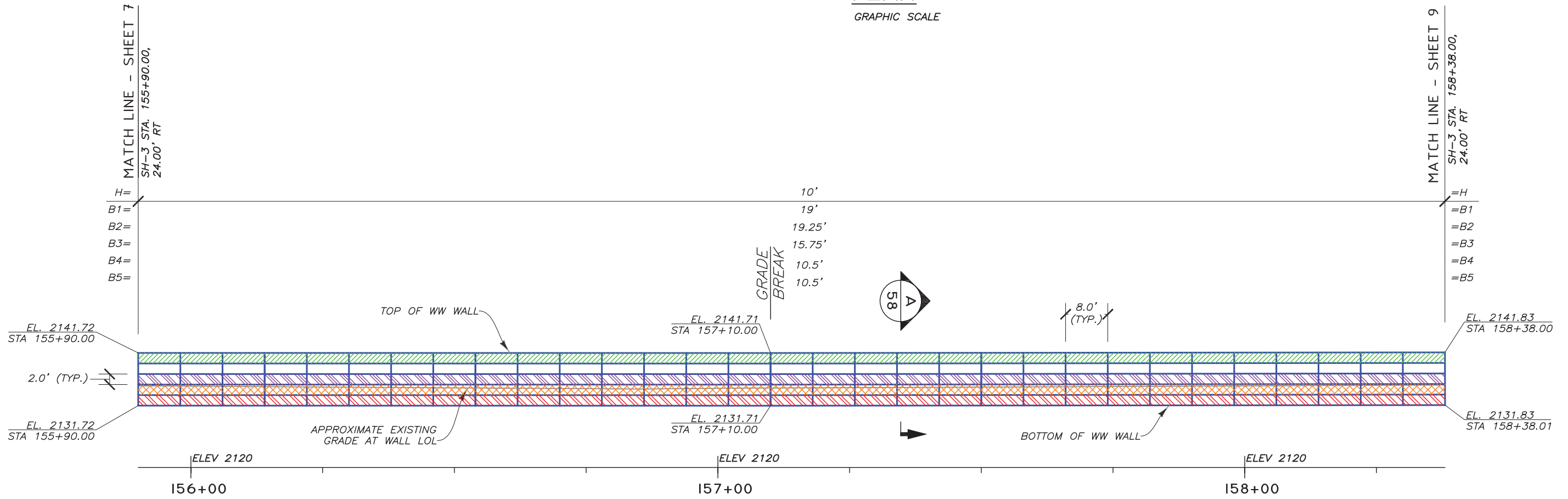

**DEVELOPED ELEVATION - (FRONT FACE)**  
GRAPHIC SCALE

**LEGEND**

	B1	8"x12", W7xW3.5-HDG	LOL	LAYOUT LINE
	B2	8"x21", W4.5xW4-HDG	H	WALL HEIGHT (BOTTOM MAT TO CAP MAT)
	B3	8"x21", W4.5xW4-HDG (W/GEOFOAM)	B	MAT LENGTH
	B4	8"x21", W4.5xW4-HDG (W/GEOFOAM)	WW	WELDED WIRE
	B5	8"x21", W4.5xW4-HDG		

THE DESIGN CONTAINED ON THESE DRAWINGS IS BASED ON INFORMATION PROVIDED BY THE OWNER. ON THE BASIS OF THIS INFORMATION, THE HILFIKER COMPANY HAS DESIGNED, AND IS RESPONSIBLE FOR THE INTERNAL STABILITY OF THE STRUCTURE ONLY. EXTERNAL STABILITY, INCLUDING FOUNDATION AND SLOPE STABILITY, IS THE RESPONSIBILITY OF THE OWNER.

REV.	DATE	BY	DESCRIPTION
0	12/30/2021	RGV	ISSUED FOR OWNER REVIEW
1	2/4/2022	RGV	ISSUED FOR OWNER REVIEW IN RESPONSE TO COMMENTS

CADD:	RGV
DESIGNED:	RGV
CHECKED:	SGC

**HILFIKER RETAINING WALLS**

1902 HilfiKER Lane  
Eureka, CA 95503-5711  
TOLL-FREE 800.752.8962  
PH 707.443.5093 FAX 707.443.2891  
WEB SITE www.hilfiKER.com E-MAIL info@hilfiKER.com

**AMERICAN GEOTECHNICS**

American Geotechnics  
5260 Chinden Blvd.  
Boise, ID 83714  
(208) 658-8700  
Fax: (208) 658-8703

PLAN & ELEVATION	
WW WALL	
SH-3, GOOSEHAVEN RD. TO ROUND LAKE RD.	
ITD	BENEWAH COUNTY, ID

DWG DATE:	4 FEB 2022
HRW NO.:	210714AW
SHEET	8
OF	61

PROFESSIONAL ENGINEER  
2/4/2022  
15993  
AN G. VAN LEUVEN  
STATE OF IDAHO

03584-SH-3\_Goosehaven\_Rd\_ID\_PREP 2-4-2022.dwg  
2/4/2022 10:54 AM  
RVanLeuven



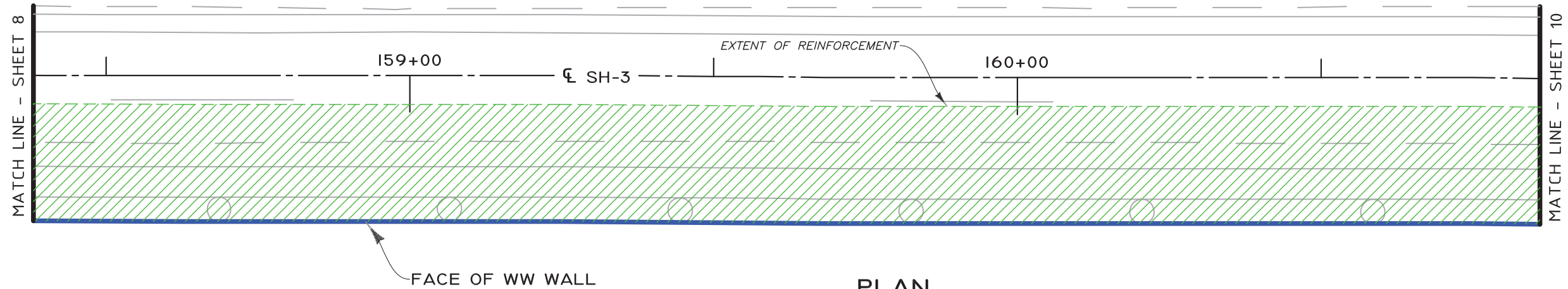
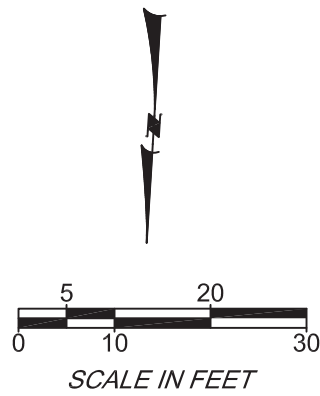

**PLAN**  
GRAPHIC SCALE

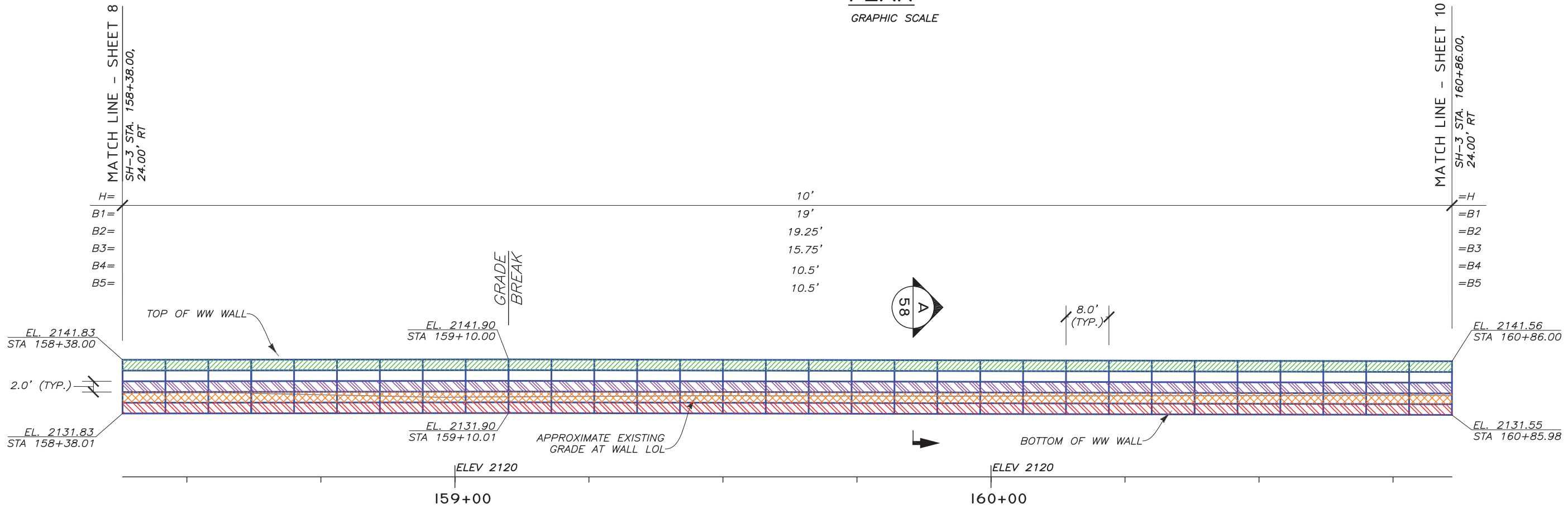

**DEVELOPED ELEVATION - (FRONT FACE)**  
GRAPHIC SCALE

**LEGEND**

	B1	8"x12", W7xW3.5-HDG	LOL	LAYOUT LINE
	B2	8"x21", W4.5xW4-HDG	H	WALL HEIGHT (BOTTOM MAT TO CAP MAT)
	B3	8"x21", W4.5xW4-HDG (W/GEOFOAM)	B	MAT LENGTH
	B4	8"x21", W4.5xW4-HDG (W/GEOFOAM)	WW	WELDED WIRE
	B5	8"x21", W4.5xW4-HDG		

03584-SH-3, Goosehaven Rd., I PREP 2-4-2022.dwg  
2/4/2022 10:54 AM  
RVanLeuven

REV.	DATE	BY	DESCRIPTION	CADD:
0	12/30/2021	RGV	ISSUED FOR OWNER REVIEW	RGV
1	2/4/2022	RGV	ISSUED FOR OWNER REVIEW IN RESPONSE TO COMMENTS	DESIGNED: RGV CHECKED: SGC

**HILFIKER RETAINING WALLS**

1902 Hilfiker Lane  
Eureka, CA 95503-5711  
TOLL-FREE 800.752.8962  
PH 707.443.5093 FAX 707.443.2891  
WEB SITE www.hilfiker.com EMAIL info@hilfiker.com

**AMERICAN GEOTECHNICS**

American Geotechnics  
5260 Chinden Blvd.  
Boise, ID 83714  
(208) 658-8700  
Fax: (208) 658-8703

PLAN & ELEVATION	DWG DATE: 4 FEB 2022
WW WALL	HRW NO.:
SH-3, GOOSEHAVEN RD. TO ROUND LAKE RD.	210714AW
ITD	SHEET 9
BENEWAH COUNTY, ID	OF 61

PROFESSIONAL ENGINEER  
2/4/2022  
15993  
AN G. VAN LEUVEN  
STATE OF IDAHO

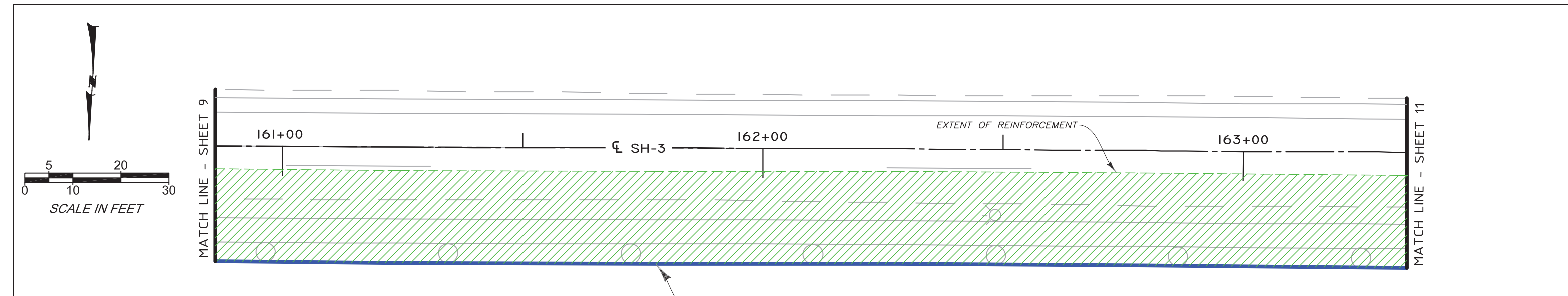

PLAN  
GRAPHIC SCALE

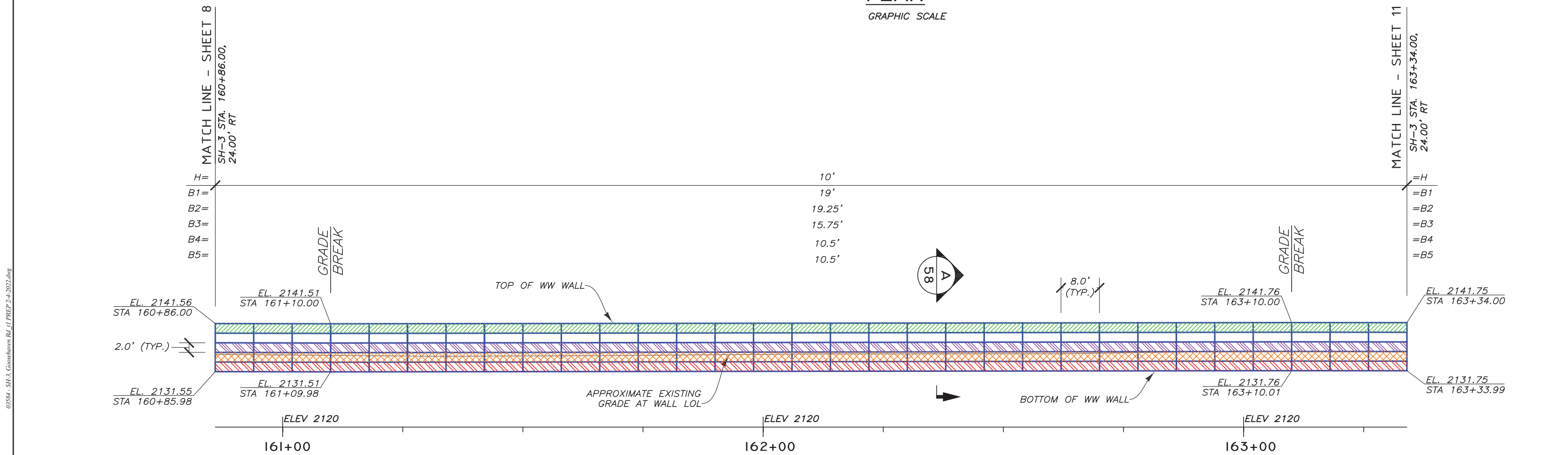

DEVELOPED ELEVATION - (FRONT FACE)  
GRAPHIC SCALE

**LEGEND**

	B1	8"X12", W7xW3.5-HDG	LOL	LAYOUT LINE
	B2	8"X21", W4.5xW4-HDG	H	WALL HEIGHT (BOTTOM MAT TO CAP MAT)
	B3	8"X21", W4.5xW4-HDG (W/GEOFOAM)	B	MAT LENGTH
	B4	8"X21", W4.5xW4-HDG (W/GEOFOAM)	WW	WELDED WIRE
	B5	8"X21", W4.5xW4-HDG		

REV.	DATE	BY	DESCRIPTION	CADD:
0	12/30/2021	RGV	ISSUED FOR OWNER REVIEW	RGV
1	2/4/2022	RGV	ISSUED FOR OWNER REVIEW IN RESPONSE TO COMMENTS	RGV
				CHECKED: SGC

**HILFIKER RETAINING WALLS**

1902 Hilfiker Lane  
Eureka, CA 95503-5711  
TOLL-FREE 800.752.8962  
PH 707.443.5093 FAX 707.443.2891  
WEB SITE www.hilfiker.com E-MAIL info@hilfiker.com

**AMERICAN GEOTECHNICS**

American Geotechnics  
5260 Chinden Blvd.  
Boise, ID 83714  
(208) 658-8700  
Fax: (208) 658-8703

PLAN & ELEVATION	DWG DATE: 4 FEB 2022
WW WALL	HRW NO.: 210714AW
SH-3, GOOSEHAVEN RD. TO ROUND LAKE RD.	SHEET 10 OF 61
ITD BENEWAH COUNTY, ID	

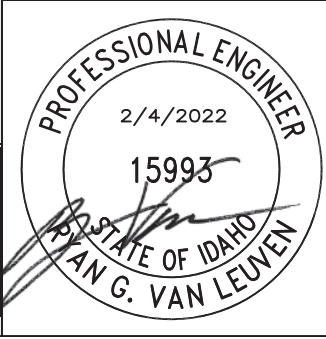

03584-SH-3\_Goosehaven\_Rd\_ID\_PREP 2-4-2022.dwg  
2/4/2022 10:54 AM  
RVanLeuven

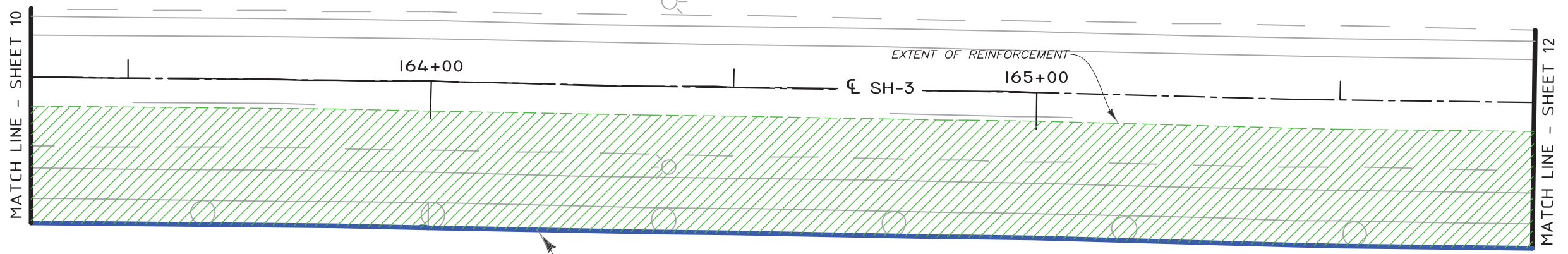
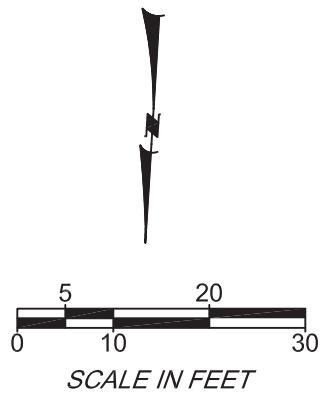

**PLAN**  
GRAPHIC SCALE

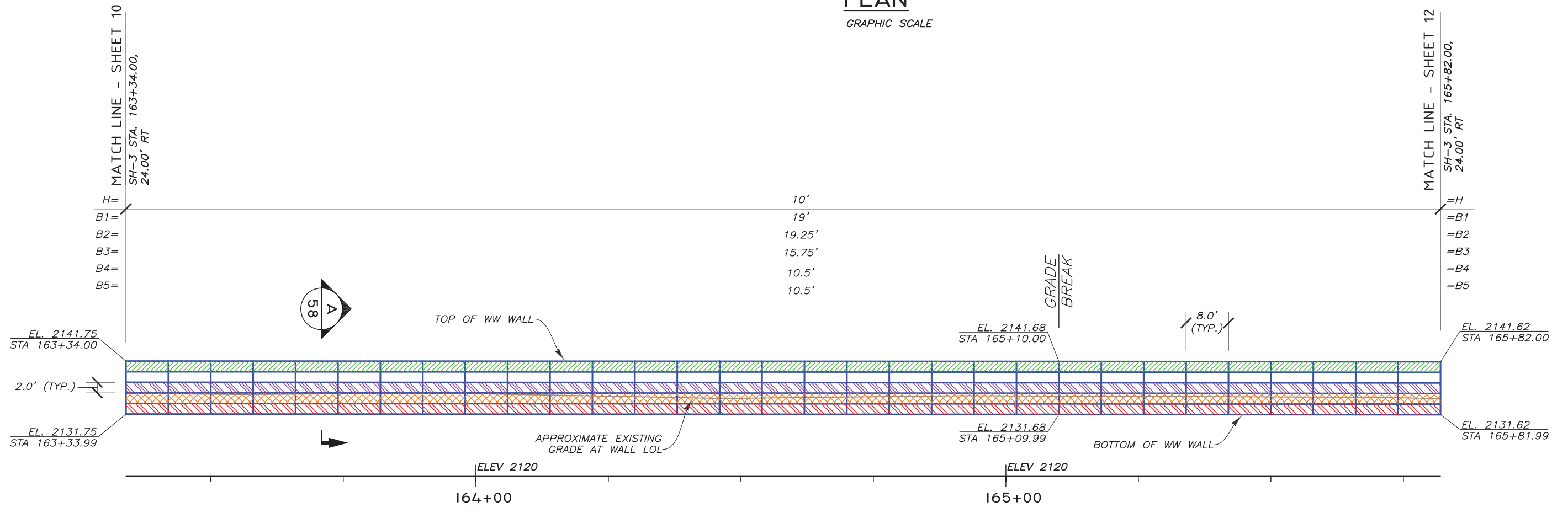

**DEVELOPED ELEVATION - (FRONT FACE)**  
GRAPHIC SCALE

**LEGEND**

	B1	8"X12", W7xW3.5-HDG	LOL	LAYOUT LINE
	B2	8"X21", W4.5xW4-HDG	H	WALL HEIGHT (BOTTOM MAT TO CAP MAT)
	B3	8"X21", W4.5xW4-HDG (W/GEOFOAM)	B	MAT LENGTH
	B4	8"X21", W4.5xW4-HDG (W/GEOFOAM)	WW	WELDED WIRE
	B5	8"X21", W4.5xW4-HDG		

03584-SH-3\_Goosehaven\_Rd\_I1\_PREP 2-4-2022.dwg  
2/4/2022 10:54 AM  
RVanLeuven

REV.	DATE	BY	DESCRIPTION	CADD:
0	12/30/2021	RGV	ISSUED FOR OWNER REVIEW	RGV
1	2/4/2022	RGV	ISSUED FOR OWNER REVIEW IN RESPONSE TO COMMENTS	DESIGNED: RGV CHECKED: SGC

**HILFIKER RETAINING WALLS**

1902 Hilfiker Lane  
Eureka, CA 95503-5711  
TOLL-FREE 800.762.8962  
PH 707.443.5093 FAX 707.443.2891  
WEB SITE www.hilfiker.com E-MAIL info@hilfiker.com

**AMERICAN GEOTECHNICS**

American Geotechnics  
5260 Chinden Blvd.  
Boise, ID 83714  
(208) 658-8700  
Fax: (208) 658-8703

PLAN & ELEVATION	DWG DATE: 4 FEB 2022
WW WALL	HRW NO.:
SH-3, GOOSEHAVEN RD. TO ROUND LAKE RD.	210714AW
ITD	SHEET
BENEWAH COUNTY, ID	11
	OF 61

PROFESSIONAL ENGINEER

2/4/2022

15993

MAN G. VAN LEUVEN

STATE OF IDAHO

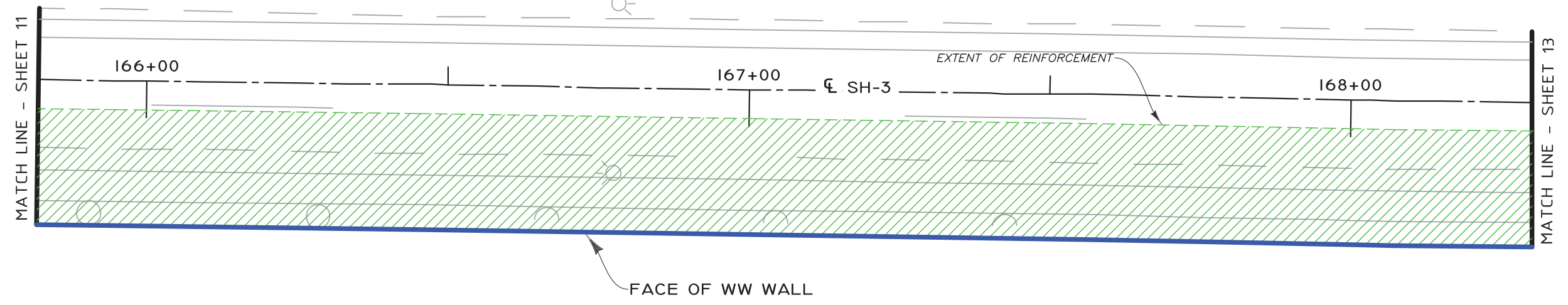
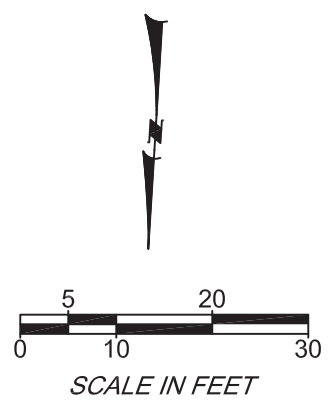

**PLAN**  
GRAPHIC SCALE

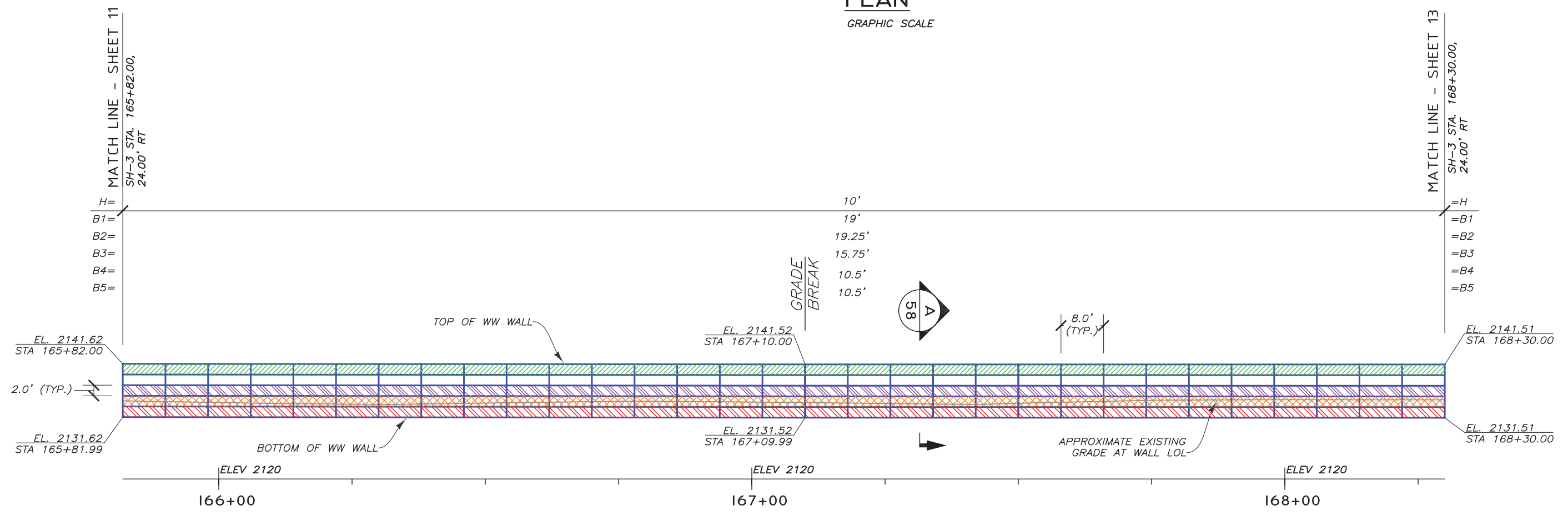

**DEVELOPED ELEVATION - (FRONT FACE)**  
GRAPHIC SCALE

**LEGEND**

	B1	8"x12", W7xW3.5-HDG	LOL	LAYOUT LINE
	B2	8"x21", W4.5xW4-HDG	H	WALL HEIGHT (BOTTOM MAT TO CAP MAT)
	B3	8"x21", W4.5xW4-HDG (W/GEOFOAM)	B	MAT LENGTH
	B4	8"x21", W4.5xW4-HDG (W/GEOFOAM)	WW	WELDED WIRE
	B5	8"x21", W4.5xW4-HDG		

03584-SH-3\_Goosehaven\_Rd\_I1\_PREP 2-4-2022.dwg  
2/4/2022 10:54 AM  
RVanLeuven

REV.	DATE	BY	DESCRIPTION	CADD:
0	12/30/2021	RGV	ISSUED FOR OWNER REVIEW	RGV
1	2/4/2022	RGV	ISSUED FOR OWNER REVIEW IN RESPONSE TO COMMENTS	DESIGNED: RGV CHECKED: SGC

**HILFIKER RETAINING WALLS**

1902 HilfiKER Lane  
Eureka, CA 95503-5711  
TOLL-FREE 800.762.8962  
PH 707.443.5093 FAX 707.443.2891  
WEB SITE www.hilfiKER.com EMAIL info@hilfiKER.com

**AMERICAN GEOTECHNICS**

American Geotechnics  
5260 Chinden Blvd.  
Boise, ID 83714  
(208) 658-8700  
Fax: (208) 658-8703

PLAN & ELEVATION	DWG DATE: 4 FEB 2022
WW WALL	HRW NO.: 210714AW
SH-3, GOOSEHAVEN RD. TO ROUND LAKE RD.	SHEET 12
ITD BENEWAH COUNTY, ID	OF 61

PROFESSIONAL ENGINEER  
2/4/2022  
15993  
RYAN G. VAN LEUVEN  
STATE OF IDAHO

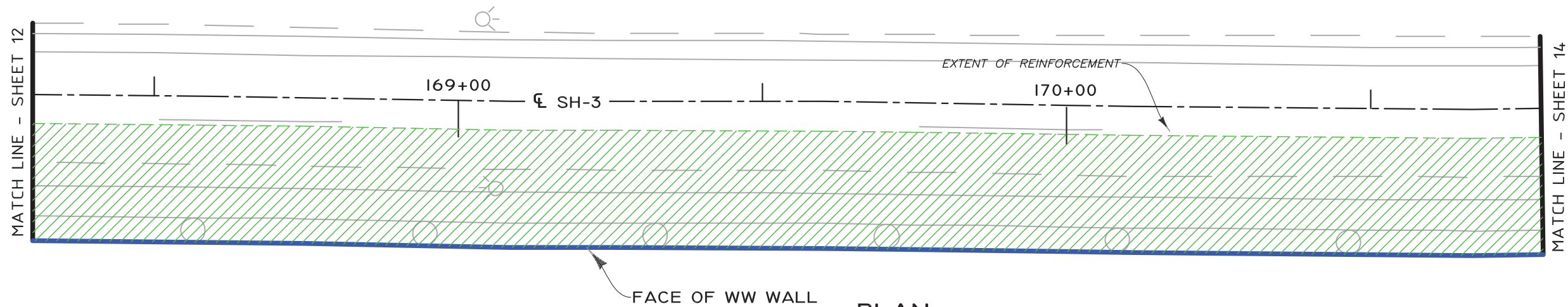
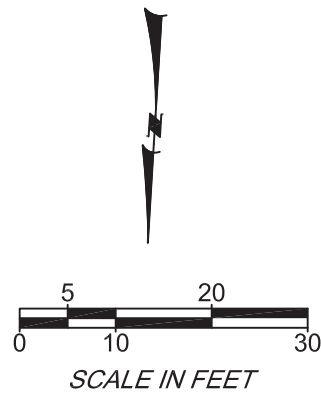

**PLAN**  
GRAPHIC SCALE

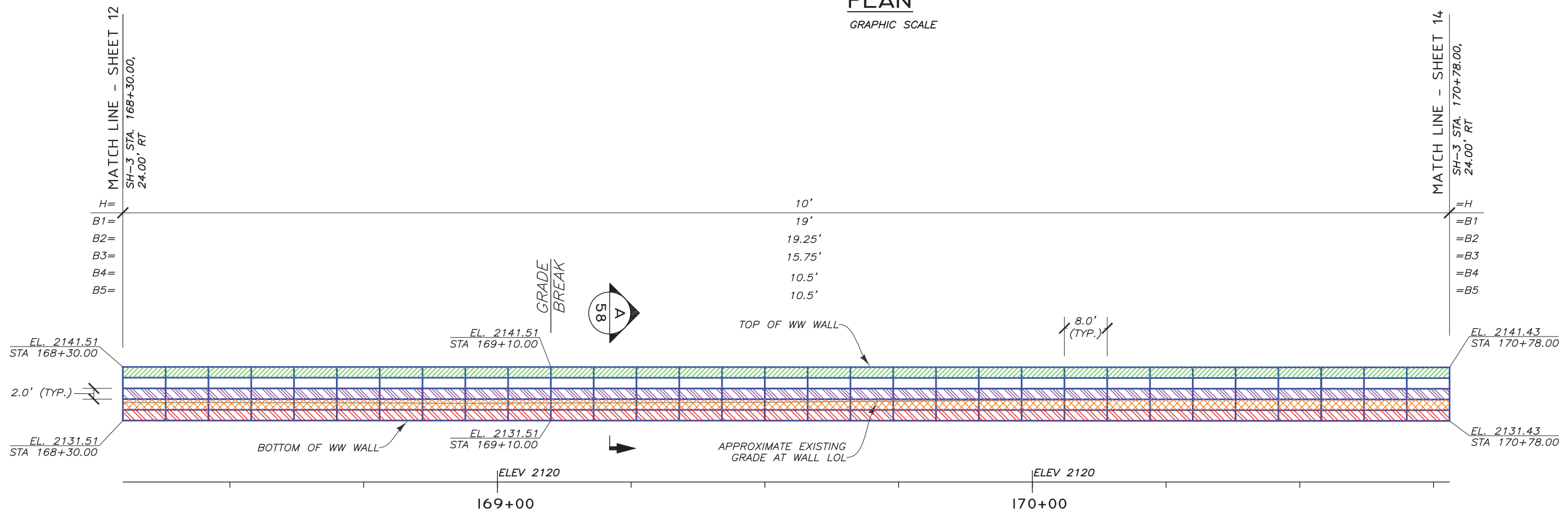

**DEVELOPED ELEVATION - (FRONT FACE)**

GRAPHIC SCALE

**LEGEND**

	B1	8"x12", W7xW3.5-HDG	LOL	LAYOUT LINE
	B2	8"x21", W4.5xW4-HDG	H	WALL HEIGHT (BOTTOM MAT TO CAP MAT)
	B3	8"x21", W4.5xW4-HDG (W/GEOFOAM)	B	MAT LENGTH
	B4	8"x21", W4.5xW4-HDG (W/GEOFOAM)	WW	WELDED WIRE
	B5	8"x21", W4.5xW4-HDG		

03584-SH-3\_Goosehaven\_Rd\_11 PREP 2-4-2022.dwg

2/4/2022 10:54 AM

THE DESIGN CONTAINED ON THESE DRAWINGS IS BASED ON INFORMATION PROVIDED BY THE OWNER. ON THE BASIS OF THIS INFORMATION, THE HILFIKER COMPANY HAS DESIGNED, AND IS RESPONSIBLE FOR THE INTERNAL STABILITY OF THE STRUCTURE ONLY. EXTERNAL STABILITY, INCLUDING FOUNDATION AND SLOPE STABILITY, IS THE RESPONSIBILITY OF THE OWNER.

REV.	DATE	BY	DESCRIPTION
0	12/30/2021	RGV	ISSUED FOR OWNER REVIEW
1	2/4/2022	RGV	ISSUED FOR OWNER REVIEW IN RESPONSE TO COMMENTS

CADD:	RGV
DESIGNED:	RGV
CHECKED:	SGC

**HILFIKER RETAINING WALLS**

1902 HilfiKER Lane  
Eureka, CA 95503-5711  
TOLL-FREE 800.752.8962  
PH 707.443.5093 FAX 707.443.2891  
WEB SITE www.hilfiKER.com EMAIL info@hilfiKER.com

**AMERICAN GEOTECHNICS**

American Geotechnics  
5260 Chinden Blvd.  
Boise, ID 83714  
(208) 658-8700  
Fax: (208) 658-8703

PLAN & ELEVATION	
WW WALL	
SH-3, GOOSEHAVEN RD. TO ROUND LAKE RD.	
ITD	BENEWAH COUNTY, ID

DWG DATE:	4 FEB 2022
HRW NO.:	210714AW
SHEET	13
OF	61

PROFESSIONAL ENGINEER

2/4/2022

15993

STATE OF IDAHO

AN G. VAN LEUVEN

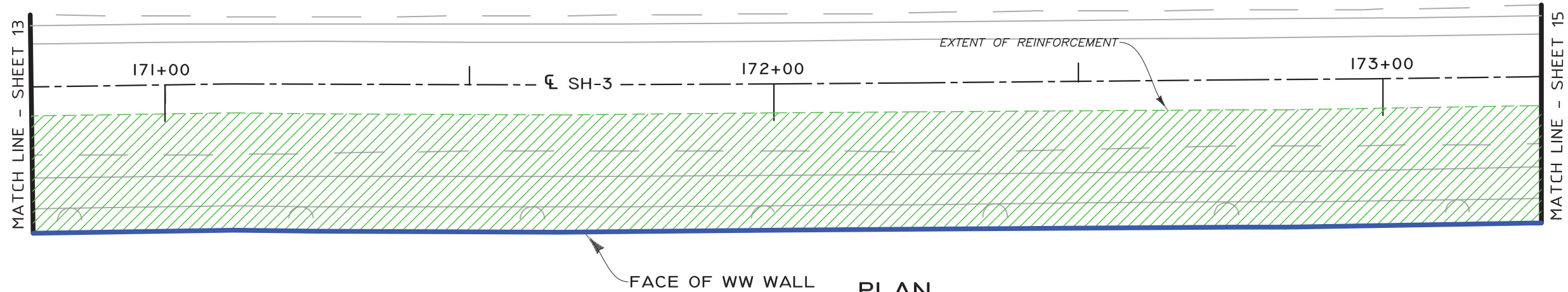
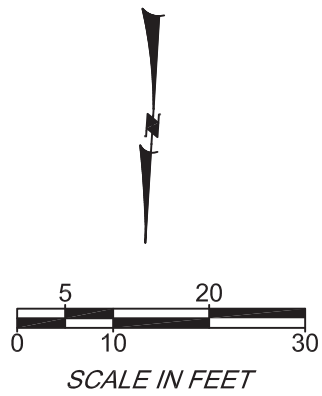

**PLAN**  
GRAPHIC SCALE

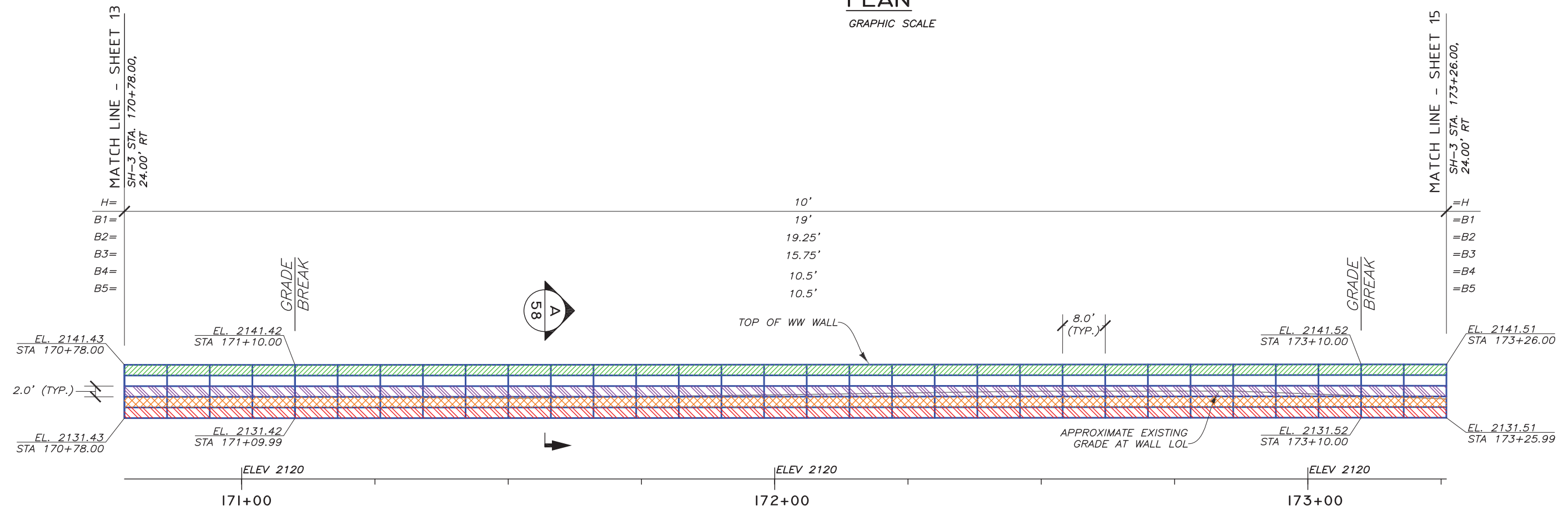

**DEVELOPED ELEVATION - (FRONT FACE)**  
GRAPHIC SCALE

**LEGEND**

	B1	8"x12", W7xW3.5-HDG	LOL	LAYOUT LINE
	B2	8"x21", W4.5xW4-HDG	H	WALL HEIGHT (BOTTOM MAT TO CAP MAT)
	B3	8"x21", W4.5xW4-HDG (W/GEOFOAM)	B	MAT LENGTH
	B4	8"x21", W4.5xW4-HDG (W/GEOFOAM)	WW	WELDED WIRE
	B5	8"x21", W4.5xW4-HDG		

03584-SH-3\_Goosehaven\_Rd\_I\_PREP 2-4-2022.dwg  
2/4/2022 10:54 AM  
RVanLeuven

REV.	DATE	BY	DESCRIPTION	CADD:
0	12/30/2021	RGV	ISSUED FOR OWNER REVIEW	RGV
1	2/4/2022	RGV	ISSUED FOR OWNER REVIEW IN RESPONSE TO COMMENTS	RGV
				CHECKED: SGC

**HILFIKER RETAINING WALLS**

1902 Hilfiker Lane  
Eureka, CA 95503-5711  
TOLL-FREE 800.752.8962  
PH 707.443.5093 FAX 707.443.2891  
WEB SITE www.hilfiker.com E-MAIL info@hilfiker.com

**AMERICAN GEOTECHNICS**

American Geotechnics  
5260 Chinden Blvd.  
Boise, ID 83714  
(208) 658-8700  
Fax: (208) 658-8703

PLAN & ELEVATION	DWG DATE: 4 FEB 2022
WW WALL	HRW NO.: 210714AW
SH-3, GOOSEHAVEN RD. TO ROUND LAKE RD.	SHEET 14 OF 61
ITD	BENEWAH COUNTY, ID

PROFESSIONAL ENGINEER

2/4/2022

15993

STATE OF IDAHO

G. VAN LEUVEN

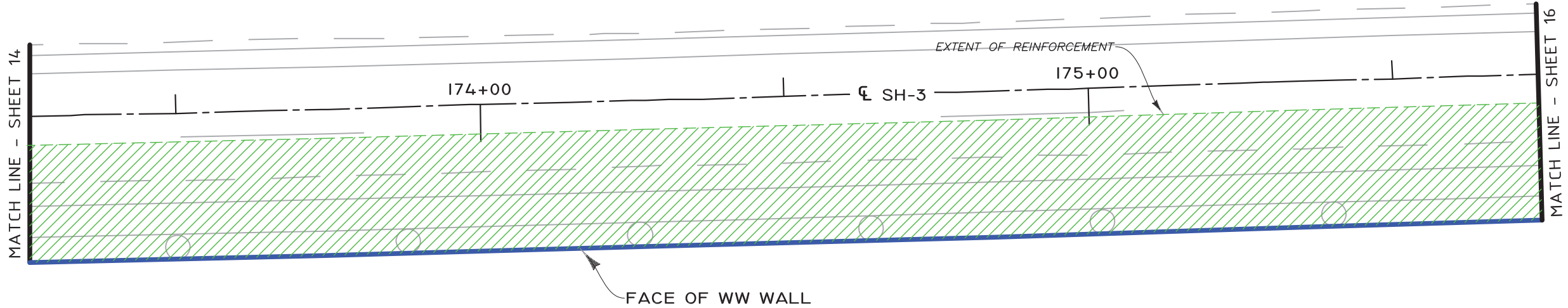
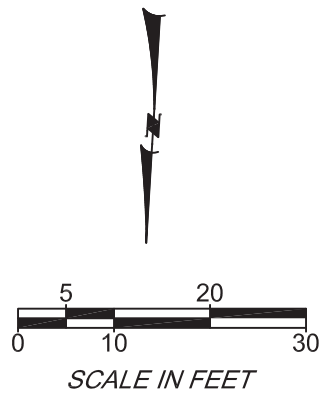

**PLAN**  
GRAPHIC SCALE

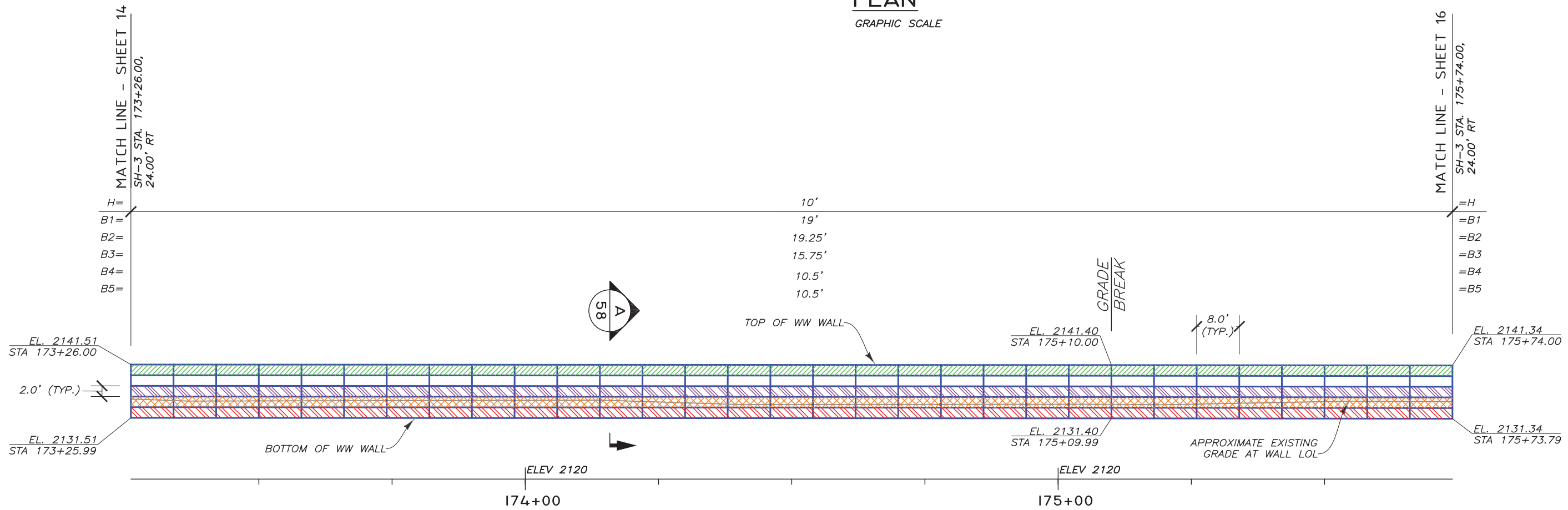

**DEVELOPED ELEVATION - (FRONT FACE)**

GRAPHIC SCALE

**LEGEND**

	B1	8"X12", W7xW3.5-HDG	LOL	LAYOUT LINE
	B2	8"X21", W4.5xW4-HDG	H	WALL HEIGHT (BOTTOM MAT TO CAP MAT)
	B3	8"X21", W4.5xW4-HDG (W/GEOFOAM)	B	MAT LENGTH
	B4	8"X21", W4.5xW4-HDG (W/GEOFOAM)	WW	WELDED WIRE
	B5	8"X21", W4.5xW4-HDG		

THE DESIGN CONTAINED ON THESE DRAWINGS IS BASED ON INFORMATION PROVIDED BY THE OWNER. ON THE BASIS OF THIS INFORMATION, THE HILFIKER COMPANY HAS DESIGNED, AND IS RESPONSIBLE FOR THE INTERNAL STABILITY OF THE STRUCTURE ONLY. EXTERNAL STABILITY, INCLUDING FOUNDATION AND SLOPE STABILITY, IS THE RESPONSIBILITY OF THE OWNER.

REV.	DATE	BY	DESCRIPTION
0	12/30/2021	RGV	ISSUED FOR OWNER REVIEW
1	2/4/2022	RGV	ISSUED FOR OWNER REVIEW IN RESPONSE TO COMMENTS

CADD:	RGV
DESIGNED:	RGV
CHECKED:	SGC

**HILFIKER RETAINING WALLS**

1902 HilfiKER Lane  
Eureka, CA 95503-5711  
TOLL-FREE 800.752.8962  
PH 707.443.5093 FAX 707.443.2891  
WEB SITE www.hilfiKER.com EMAIL info@hilfiKER.com

**AMERICAN GEOTECHNICS**

American Geotechnics  
5260 Chinden Blvd.  
Boise, ID 83714  
(208) 658-8700  
Fax: (208) 658-8703

PLAN & ELEVATION	DWG DATE: 4 FEB 2022
WW WALL	HRW NO.:
SH-3, GOOSEHAVEN RD. TO ROUND LAKE RD.	210714AW
ITD	SHEET 15
BENEWAH COUNTY, ID	OF 61

PROFESSIONAL ENGINEER

2/4/2022

15993

RYAN G. VAN LEUVEN

STATE OF IDAHO

03584-SH-3\_Goosehaven\_Rd\_ID\_PREP 2-4-2022.dwg  
2/4/2022 10:54 AM  
RVanLeuven

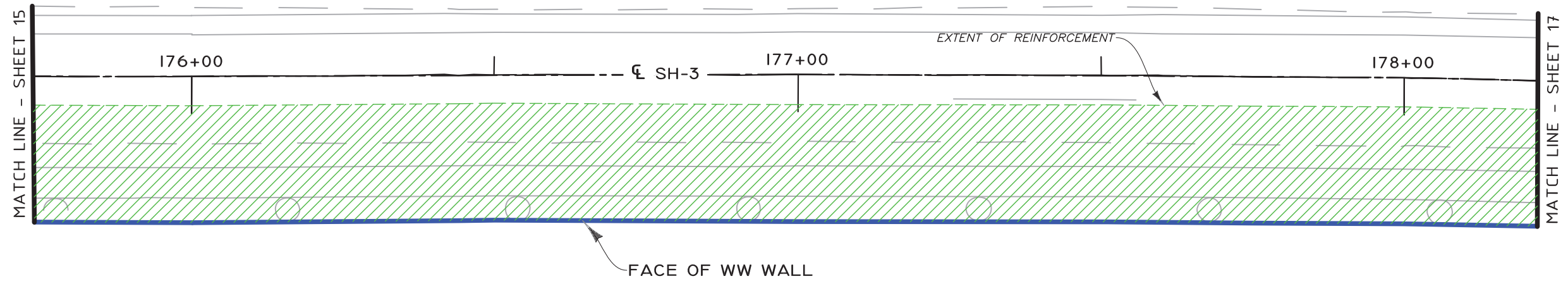
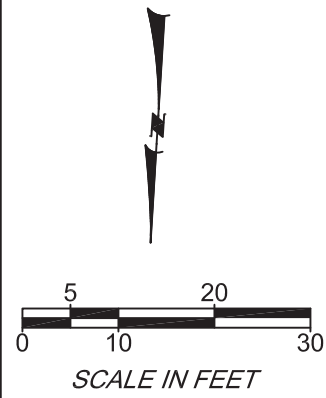

**PLAN**  
GRAPHIC SCALE

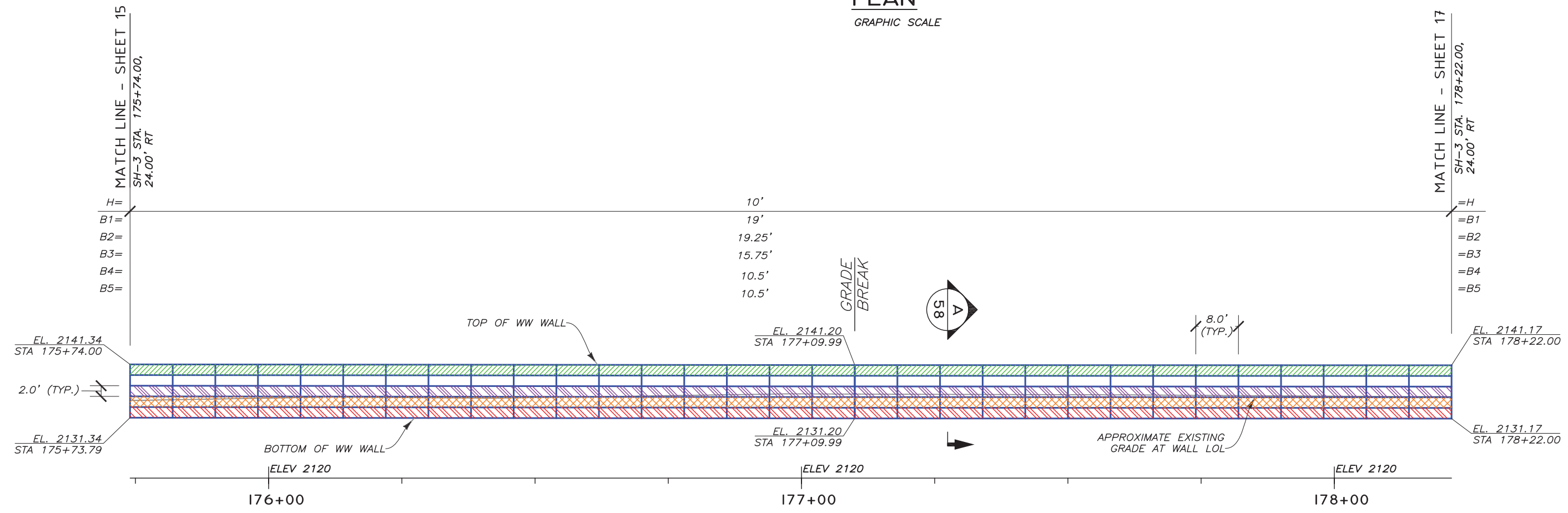

**DEVELOPED ELEVATION - (FRONT FACE)**  
GRAPHIC SCALE

**LEGEND**

	B1	8"X12", W7xW3.5-HDG	LOL	LAYOUT LINE
	B2	8"X21", W4.5xW4-HDG	H	WALL HEIGHT (BOTTOM MAT TO CAP MAT)
	B3	8"X21", W4.5xW4-HDG (W/GEOFOAM)	B	MAT LENGTH
	B4	8"X21", W4.5xW4-HDG (W/GEOFOAM)	WW	WELDED WIRE
	B5	8"X21", W4.5xW4-HDG		

03584-SH-3\_Goosehaven\_Rd\_ID PREP 2-4-2022.dwg  
2/4/2022 10:54 AM  
RVanLeuven

THE DESIGN CONTAINED ON THESE DRAWINGS IS BASED ON INFORMATION PROVIDED BY THE OWNER. ON THE BASIS OF THIS INFORMATION, THE HILFIKER COMPANY HAS DESIGNED, AND IS RESPONSIBLE FOR THE INTERNAL STABILITY OF THE STRUCTURE ONLY. EXTERNAL STABILITY, INCLUDING FOUNDATION AND SLOPE STABILITY, IS THE RESPONSIBILITY OF THE OWNER.

REV.	DATE	BY	DESCRIPTION	CADD:
0	12/30/2021	RGV	ISSUED FOR OWNER REVIEW	RGV
1	2/4/2022	RGV	ISSUED FOR OWNER REVIEW IN RESPONSE TO COMMENTS	DESIGNED: RGV
				CHECKED: SGC

**HILFIKER RETAINING WALLS**

1902 Hilfiker Lane  
Eureka, CA 95503-5711  
TOLL-FREE 800.752.8962  
PH 707.443.5093 FAX 707.443.2891  
WEB SITE www.hilfiker.com EMAIL info@hilfiker.com

**AMERICAN GEOTECHNICS**

American Geotechnics  
5260 Chinden Blvd.  
Boise, ID 83714  
(208) 658-8700  
Fax: (208) 658-8703

PLAN & ELEVATION	DWG DATE: 4 FEB 2022
WW WALL	HRW NO.: 210714AW
SH-3, GOOSEHAVEN RD. TO ROUND LAKE RD.	SHEET 16 OF 61
ITD BENEWAH COUNTY, ID	

PROFESSIONAL ENGINEER  
2/4/2022  
15993  
AN G. VAN LEUVEN  
STATE OF IDAHO



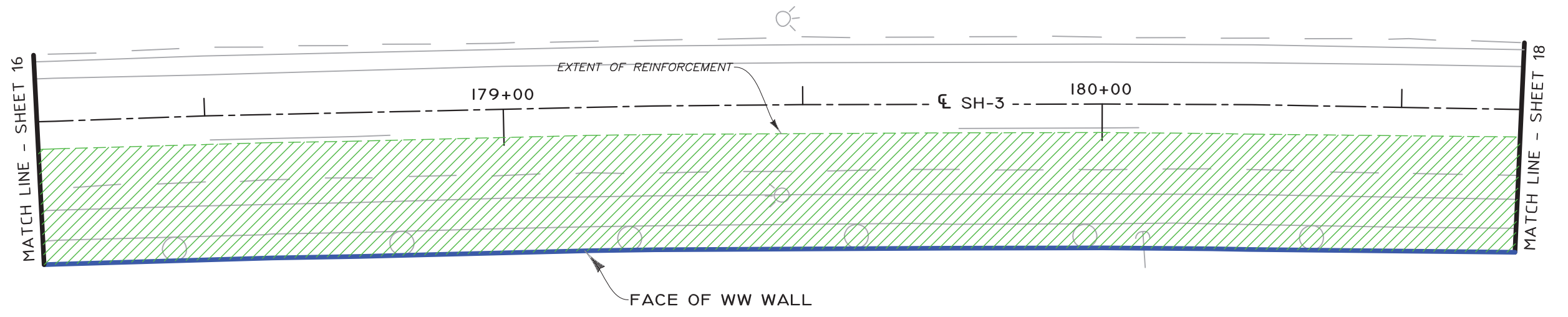
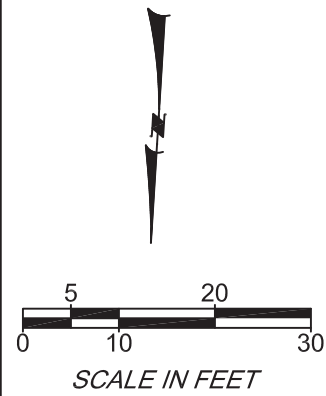

**PLAN**  
GRAPHIC SCALE

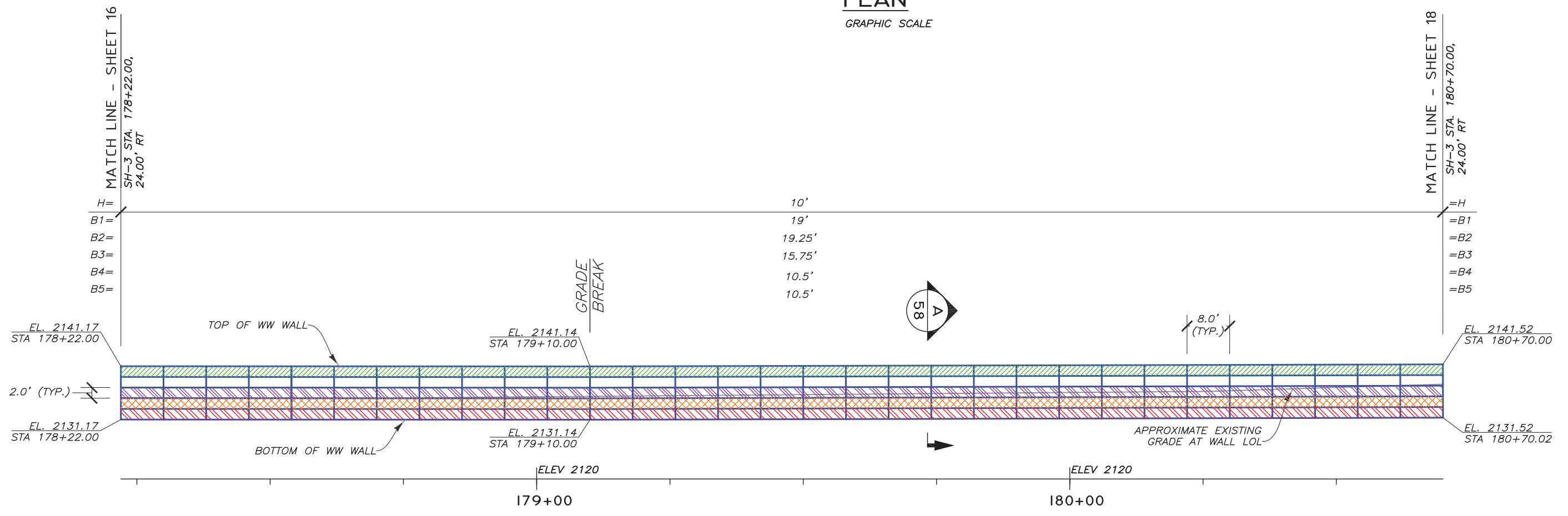

**DEVELOPED ELEVATION - (FRONT FACE)**  
GRAPHIC SCALE

**LEGEND**

	B1	8"x12", W7xW3.5-HDG	LOL	LAYOUT LINE
	B2	8"x21", W4.5xW4-HDG	H	WALL HEIGHT (BOTTOM MAT TO CAP MAT)
	B3	8"x21", W4.5xW4-HDG (W/GEOFOAM)	B	MAT LENGTH
	B4	8"x21", W4.5xW4-HDG (W/GEOFOAM)	WW	WELDED WIRE
	B5	8"x21", W4.5xW4-HDG		

03584-SH-3\_Goosehaven\_Rd\_ID PREP 2-4-2022.dwg  
2/4/2022 10:54 AM  
RVanLeuven

REV.	DATE	BY	DESCRIPTION	CADD:
0	12/30/2021	RGV	ISSUED FOR OWNER REVIEW	RGV
1	2/4/2022	RGV	ISSUED FOR OWNER REVIEW IN RESPONSE TO COMMENTS	RGV
				CHECKED: SGC

**HILFIKER RETAINING WALLS**

1902 Hilfiker Lane  
Eureka, CA 95503-5711  
TOLL-FREE 800.752.8962  
PH 707.443.5093 FAX 707.443.2891  
WEB SITE www.hilfiker.com E-MAIL info@hilfiker.com

**AMERICAN GEOTECHNICS**

American Geotechnics  
5260 Chinden Blvd.  
Boise, ID 83714  
(208) 658-8700  
Fax: (208) 658-8703

PLAN & ELEVATION	DWG DATE: 4 FEB 2022
WW WALL	HRW NO.: 210714AW
SH-3, GOOSEHAVEN RD. TO ROUND LAKE RD.	SHEET 17 OF 61
ITD BENEWAH COUNTY, ID	

PROFESSIONAL ENGINEER  
2/4/2022  
15993  
STATE OF IDAHO  
G. VAN LEUVEN

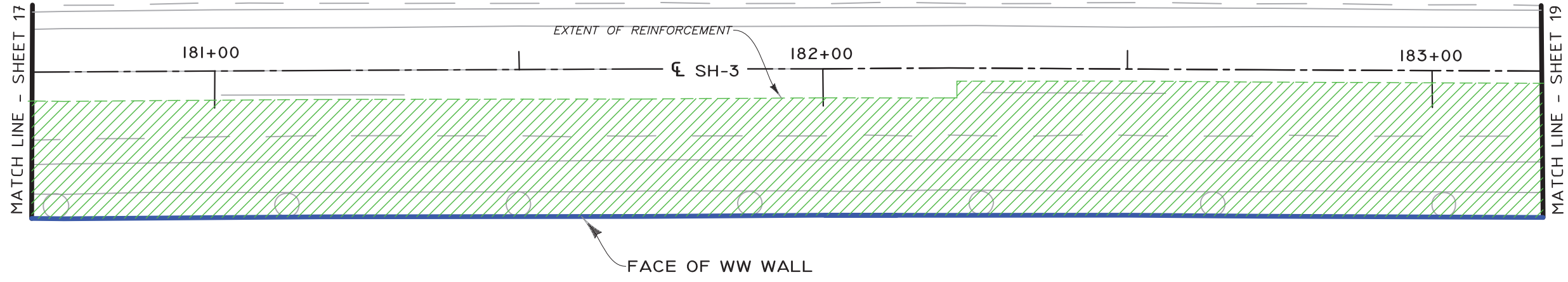
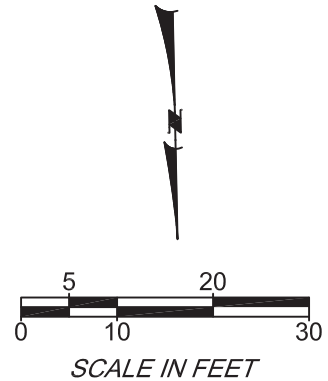

**PLAN**  
GRAPHIC SCALE

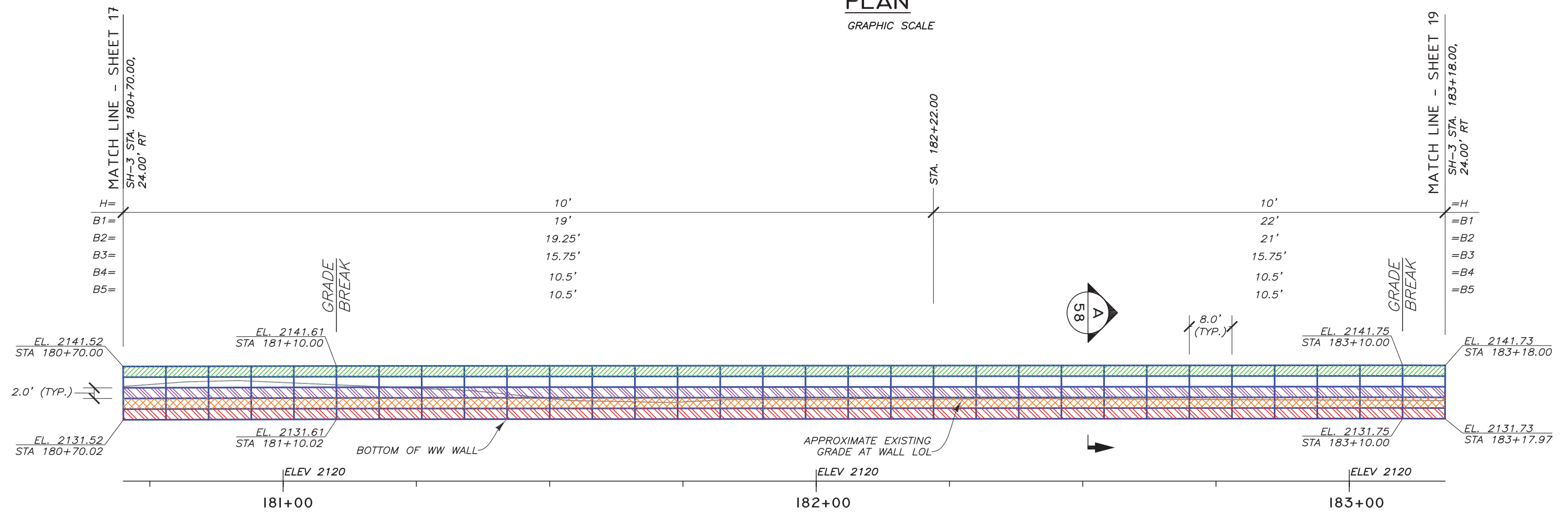

**DEVELOPED ELEVATION - (FRONT FACE)**  
GRAPHIC SCALE

LEGEND			
	B1 8"x12", W7xW3.5-HDG	LOL	LAYOUT LINE
	B2 8"x21", W4.5xW4-HDG	H	WALL HEIGHT (BOTTOM MAT TO CAP MAT)
	B3 8"x21", W4.5xW4-HDG (W/GEOFOAM)	B	MAT LENGTH
	B4 8"x21", W4.5xW4-HDG (W/GEOFOAM)	WW	WELDED WIRE
	B5 8"x21", W4.5xW4-HDG		

THE DESIGN CONTAINED ON THESE DRAWINGS IS BASED ON INFORMATION PROVIDED BY THE OWNER. ON THE BASIS OF THIS INFORMATION, THE HILFIKER COMPANY HAS DESIGNED, AND IS RESPONSIBLE FOR THE INTERNAL STABILITY OF THE STRUCTURE ONLY. EXTERNAL STABILITY, INCLUDING FOUNDATION AND SLOPE STABILITY, IS THE RESPONSIBILITY OF THE OWNER.

REV.	DATE	BY	DESCRIPTION
0	12/30/2021	RGV	ISSUED FOR OWNER REVIEW
1	2/4/2022	RGV	ISSUED FOR OWNER REVIEW IN RESPONSE TO COMMENTS

CADD:	RGV
DESIGNED:	RGV
CHECKED:	SGC

**HILFIKER RETAINING WALLS**

1902 Hilfiker Lane  
Eureka, CA 95503-5711  
TOLL-FREE 800.752.8962  
PH 707.443.5093 FAX 707.443.2891  
WEB SITE www.hilfiker.com E-MAIL info@hilfiker.com

**AMERICAN GEOTECHNICS**

American Geotechnics  
5260 Chinden Blvd.  
Boise, ID 83714  
(208) 658-8700  
Fax: (208) 658-8703

PLAN & ELEVATION	DWG DATE: 4 FEB 2022
WW WALL	HRW NO.:
SH-3, GOOSEHAVEN RD. TO ROUND LAKE RD.	210714AW
ITD	SHEET
BENEWAH COUNTY, ID	18
	OF 61

PROFESSIONAL ENGINEER

2/4/2022

15993

STATE OF IDAHO

G. VAN LEUVEN

03584-SH-3\_Goosehaven\_Rd\_I1\_PREP 2-4-2022.dwg  
2/4/2022 10:54 AM  
RVanLeuven

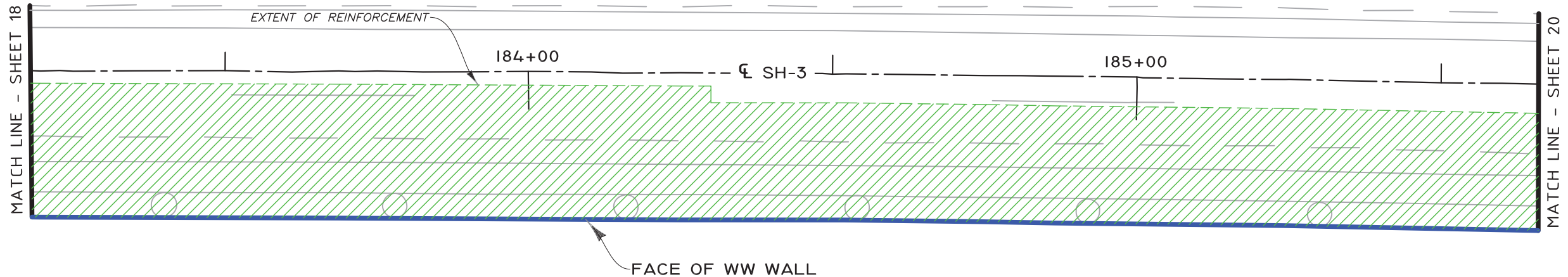
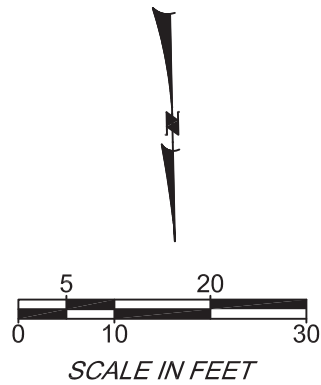

**PLAN**  
GRAPHIC SCALE

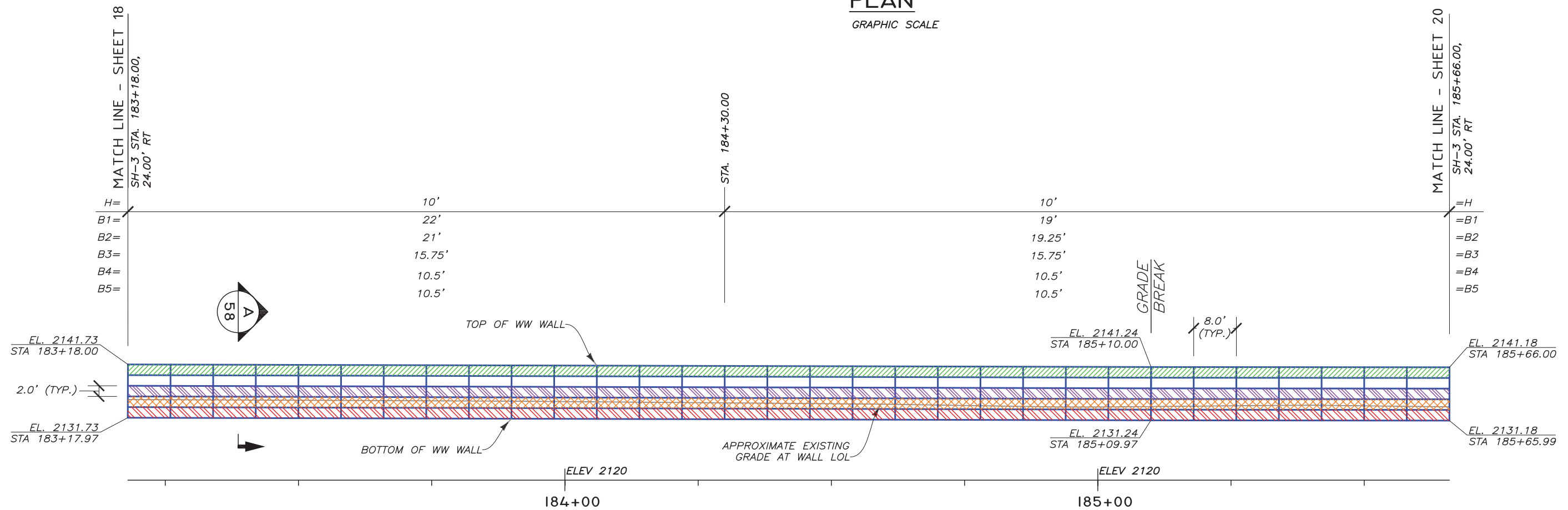

**DEVELOPED ELEVATION - (FRONT FACE)**

GRAPHIC SCALE

**LEGEND**

	B1	8"x12", W7xW3.5-HDG	LOL	LAYOUT LINE
	B2	8"x21", W4.5xW4-HDG	H	WALL HEIGHT (BOTTOM MAT TO CAP MAT)
	B3	8"x21", W4.5xW4-HDG (W/GEOFOAM)	B	MAT LENGTH
	B4	8"x21", W4.5xW4-HDG (W/GEOFOAM)	WW	WELDED WIRE
	B5	8"x21", W4.5xW4-HDG		

03584-SH-3\_Goosehaven\_Rd\_11\_PREP 2-4-2022.dwg

2/4/2022 10:54 AM

REV.	DATE	BY	DESCRIPTION	CADD:
0	12/30/2021	RGV	ISSUED FOR OWNER REVIEW	RGV
1	2/4/2022	RGV	ISSUED FOR OWNER REVIEW IN RESPONSE TO COMMENTS	RGV
				CHECKED: SGC

**HILFIKER RETAINING WALLS**

1902 Hilfiker Lane  
Eureka, CA 95503-5711  
TOLL-FREE 800.752.8962  
PH 707.443.5093 FAX 707.443.2891  
WEB SITE www.hilfiker.com E-MAIL info@hilfiker.com

**AMERICAN GEOTECHNICS**

American Geotechnics  
5260 Chinden Blvd.  
Boise, ID 83714  
(208) 658-8700  
Fax: (208) 658-8703

PLAN & ELEVATION  
WW WALL  
SH-3, GOOSEHAVEN RD.  
TO ROUND LAKE RD.  
ITD BENEWAH COUNTY, ID

DWG DATE:	4 FEB 2022
HRW NO.:	210714AW
SHEET	19
OF	61

PROFESSIONAL ENGINEER  
2/4/2022  
15993  
BY:   
RYAN G. VAN LEUVEN  
STATE OF IDAHO

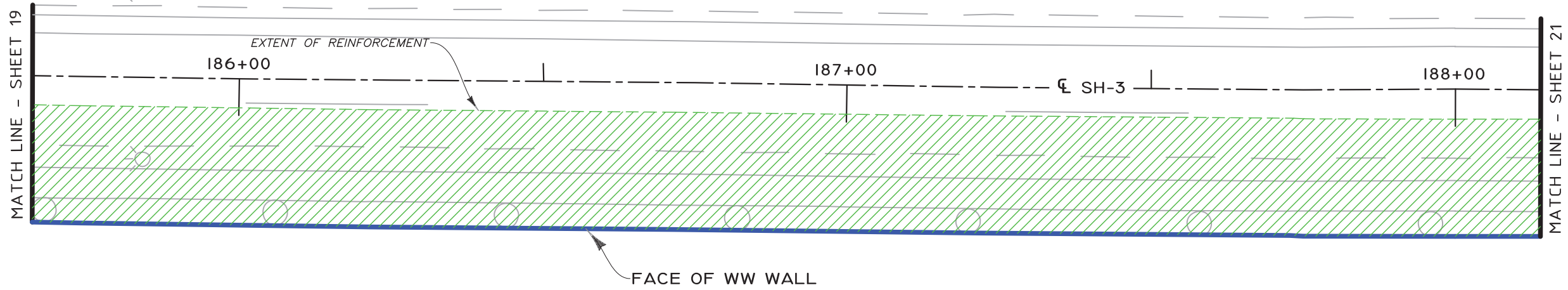
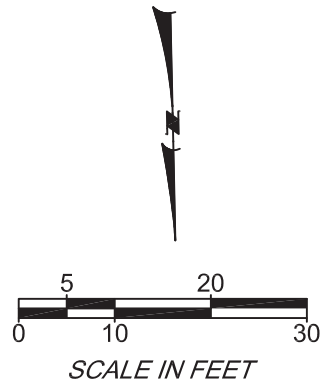

**PLAN**  
GRAPHIC SCALE

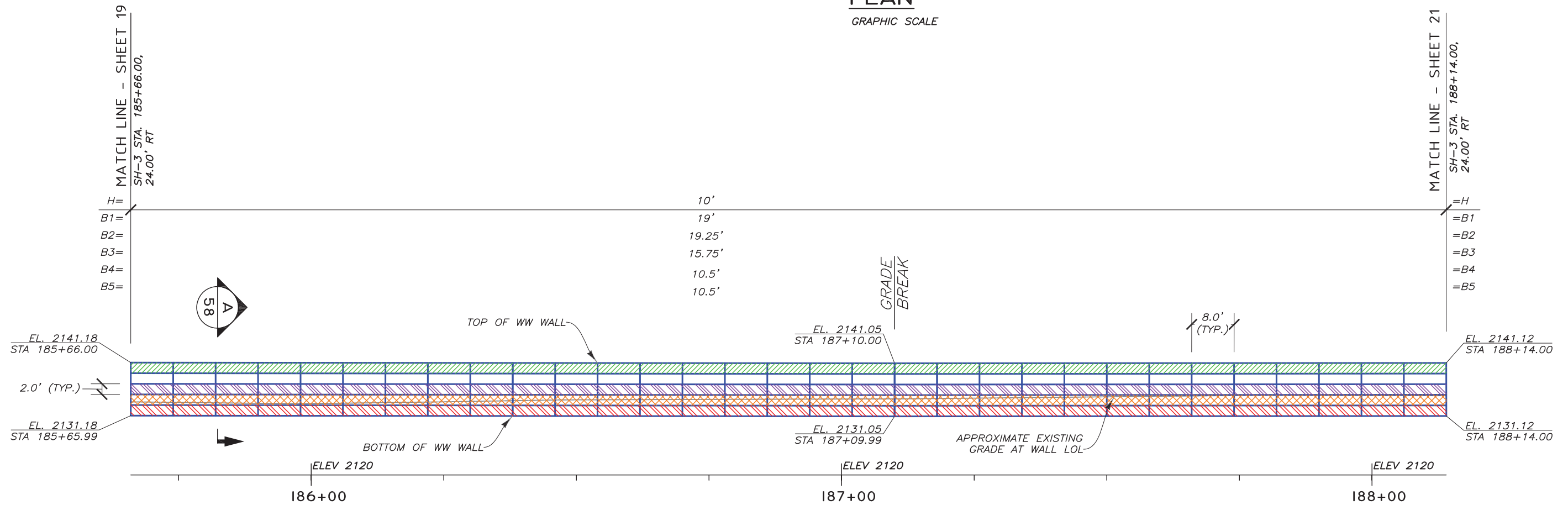

**DEVELOPED ELEVATION - (FRONT FACE)**  
GRAPHIC SCALE

**LEGEND**

	B1	8"x12", W7xW3.5-HDG	LOL	LAYOUT LINE
	B2	8"x21", W4.5xW4-HDG	H	WALL HEIGHT (BOTTOM MAT TO CAP MAT)
	B3	8"x21", W4.5xW4-HDG (W/GEOFOAM)	B	MAT LENGTH
	B4	8"x21", W4.5xW4-HDG (W/GEOFOAM)	WW	WELDED WIRE
	B5	8"x21", W4.5xW4-HDG		

03584-SH-3\_Goosehaven\_Rd\_I\_PREP 2-4-2022.dwg

2/4/2022 10:54 AM

REV.	DATE	BY	DESCRIPTION	CADD:
0	12/30/2021	RGV	ISSUED FOR OWNER REVIEW	RGV
1	2/4/2022	RGV	ISSUED FOR OWNER REVIEW IN RESPONSE TO COMMENTS	RGV
				SGC

**HILFIKER RETAINING WALLS**

1902 Hilfiker Lane  
Eureka, CA 95503-5711  
TOLL-FREE 800.762.8962  
PH 707.443.5093 FAX 707.443.2891  
WEB SITE www.hilfiker.com EMAIL info@hilfiker.com

**AMERICAN GEOTECHNICS**

American Geotechnics  
5260 Chinden Blvd.  
Boise, ID 83714  
(208) 658-8700  
Fax: (208) 658-8703

PLAN & ELEVATION  
WW WALL  
SH-3, GOOSEHAVEN RD.  
TO ROUND LAKE RD.  
ITD BENEWAH COUNTY, ID

DWG DATE:	4 FEB 2022
HRW NO.:	210714AW
SHEET	20
OF	61

PROFESSIONAL ENGINEER  
2/4/2022  
15993  
  
STATE OF IDAHO  
VAN G. VAN LEUVEN

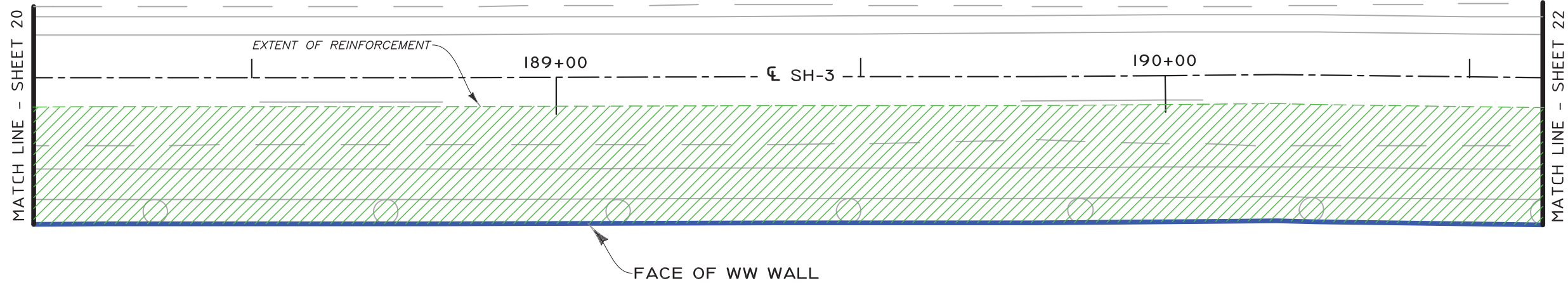
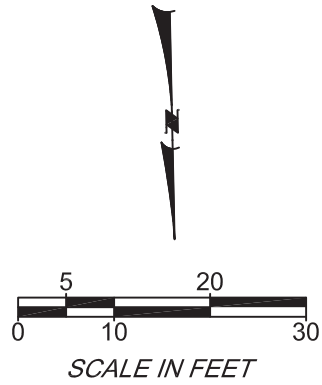

**PLAN**  
GRAPHIC SCALE

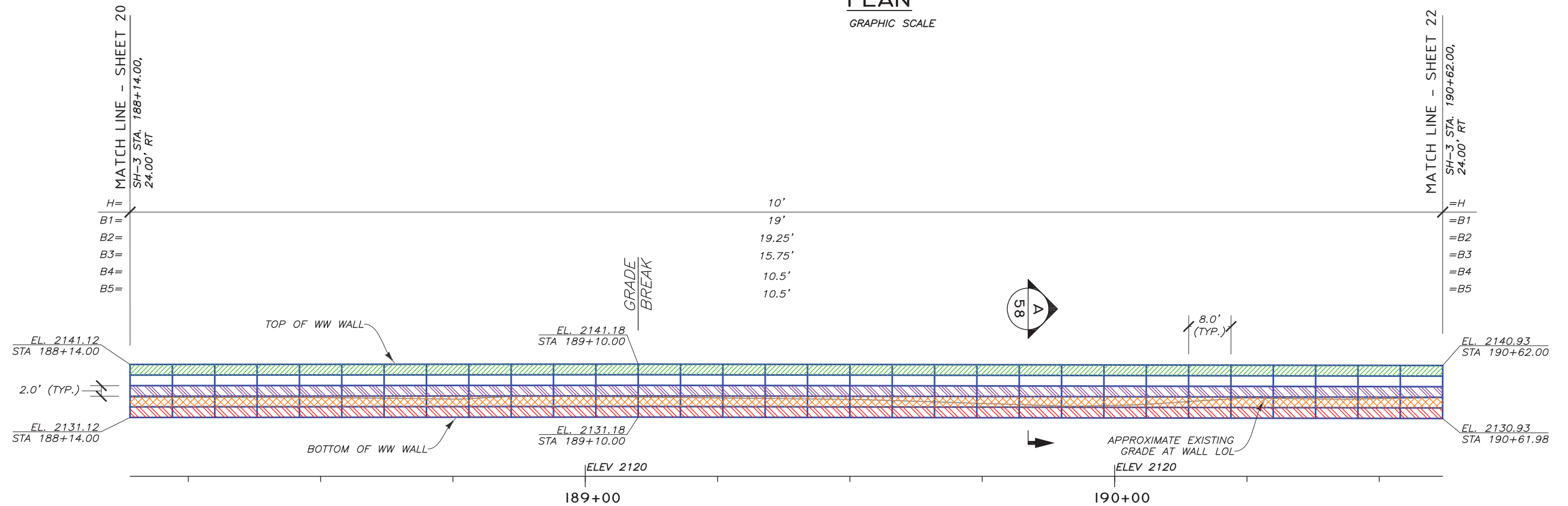

**DEVELOPED ELEVATION - (FRONT FACE)**

GRAPHIC SCALE

**LEGEND**

	B1	8"x12", W7xW3.5-HDG	LOL	LAYOUT LINE
	B2	8"x21", W4.5xW4-HDG	H	WALL HEIGHT (BOTTOM MAT TO CAP MAT)
	B3	8"x21", W4.5xW4-HDG (W/GEOFOAM)	B	MAT LENGTH
	B4	8"x21", W4.5xW4-HDG (W/GEOFOAM)	WW	WELDED WIRE
	B5	8"x21", W4.5xW4-HDG		

03584-SH-3\_Goosehaven\_Rd\_I1\_PREP 2-4-2022.dwg

R:\VanLeuven

REV.	DATE	BY	DESCRIPTION	CADD:
0	12/30/2021	RGV	ISSUED FOR OWNER REVIEW	RGV
1	2/4/2022	RGV	ISSUED FOR OWNER REVIEW IN RESPONSE TO COMMENTS	RGV
				CHECKED: SGC

**HILFIKER RETAINING WALLS**

1902 Hilfiker Lane  
Eureka, CA 95503-5711  
TOLL-FREE 800.762.8962  
PH 707.443.5093 FAX 707.443.2891  
WEB SITE www.hilfiker.com E-MAIL info@hilfiker.com

**AMERICAN GEOTECHNICS**

American Geotechnics  
5260 Chinden Blvd.  
Boise, ID 83714  
(208) 658-8700  
Fax: (208) 658-8703

PLAN & ELEVATION	
WW WALL	
SH-3, GOOSEHAVEN RD. TO ROUND LAKE RD.	
ITD	BENEWAH COUNTY, ID

DWG DATE:	4 FEB 2022
HRW NO.:	210714AW
SHEET	21
OF	61

PROFESSIONAL ENGINEER

2/4/2022

15993

STATE OF IDAHO

PHILIP G. VAN LEUVEN

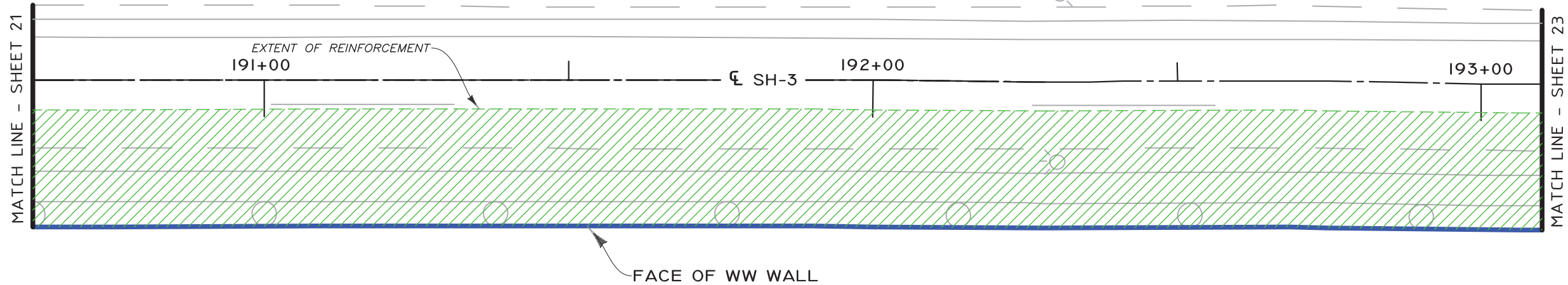
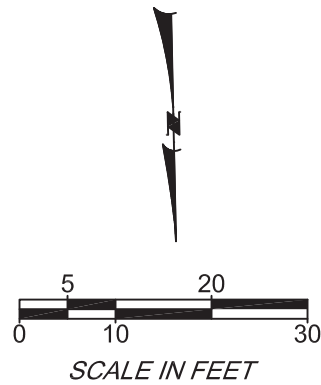

**PLAN**  
GRAPHIC SCALE

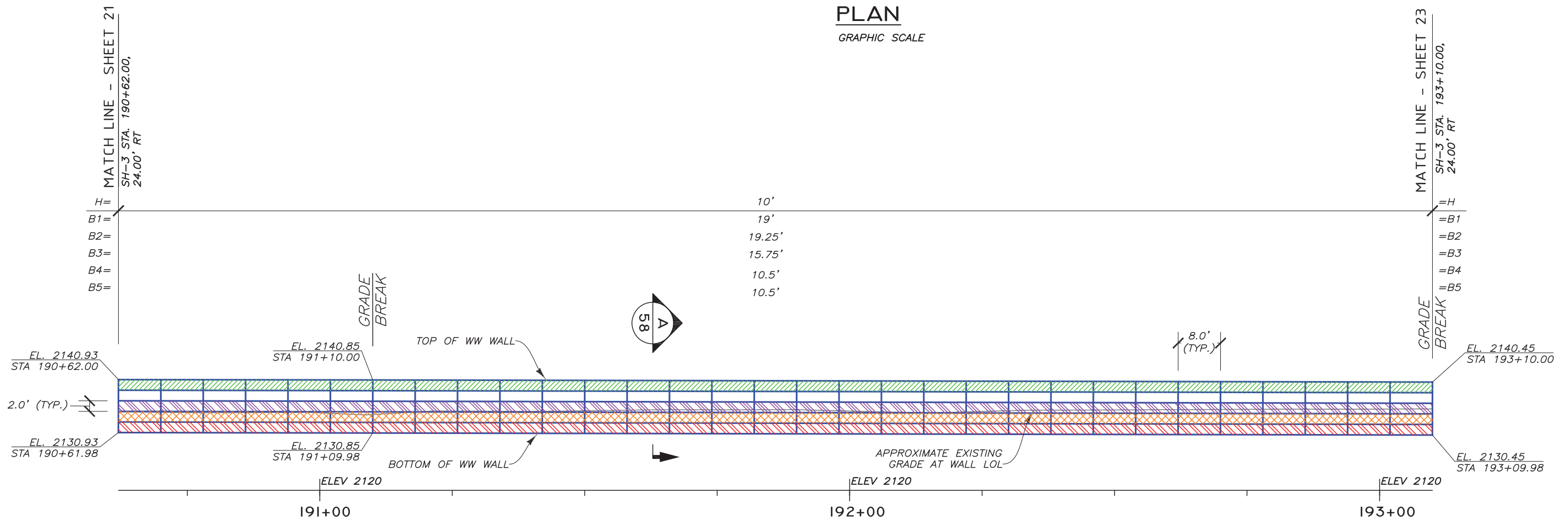

**DEVELOPED ELEVATION - (FRONT FACE)**

GRAPHIC SCALE

**LEGEND**

	B1	8"x12", W7xW3.5-HDG	LOL	LAYOUT LINE
	B2	8"x21", W4.5xW4-HDG	H	WALL HEIGHT (BOTTOM MAT TO CAP MAT)
	B3	8"x21", W4.5xW4-HDG (W/GEOFOAM)	B	MAT LENGTH
	B4	8"x21", W4.5xW4-HDG (W/GEOFOAM)	WW	WELDED WIRE
	B5	8"x21", W4.5xW4-HDG		

03584-SH-3\_Goosehaven\_Rd\_ID\_PREP 2-4-2022.dwg  
2/4/2022 10:54 AM  
RVanLeuven

REV.	DATE	BY	DESCRIPTION	CADD:
0	12/30/2021	RGV	ISSUED FOR OWNER REVIEW	RGV
1	2/4/2022	RGV	ISSUED FOR OWNER REVIEW IN RESPONSE TO COMMENTS	RGV
				CHECKED: SGC

**HILFIKER RETAINING WALLS**

1902 Hilfiker Lane  
Eureka, CA 95503-5711  
TOLL-FREE 800.762.8962  
PH 707.443.5093 FAX 707.443.2891  
WEB SITE www.hilfiker.com EMAIL info@hilfiker.com

**AMERICAN GEOTECHNICS**

American Geotechnics  
5260 Chinden Blvd.  
Boise, ID 83714  
(208) 658-8700  
Fax: (208) 658-8703

PLAN & ELEVATION	
WW WALL	
SH-3, GOOSEHAVEN RD. TO ROUND LAKE RD.	
ITD	BENEWAH COUNTY, ID

DWG DATE:	4 FEB 2022
HRW NO.:	210714AW
SHEET	22
OF	61

PROFESSIONAL ENGINEER

2/4/2022

15993

STATE OF IDAHO

AN G. VAN LEUVEN

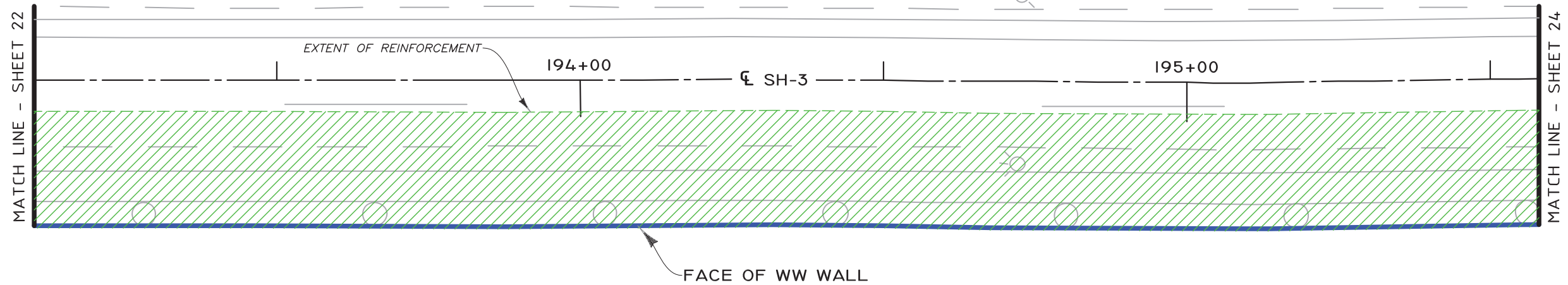
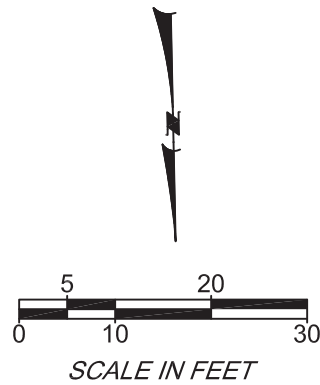

**PLAN**  
GRAPHIC SCALE

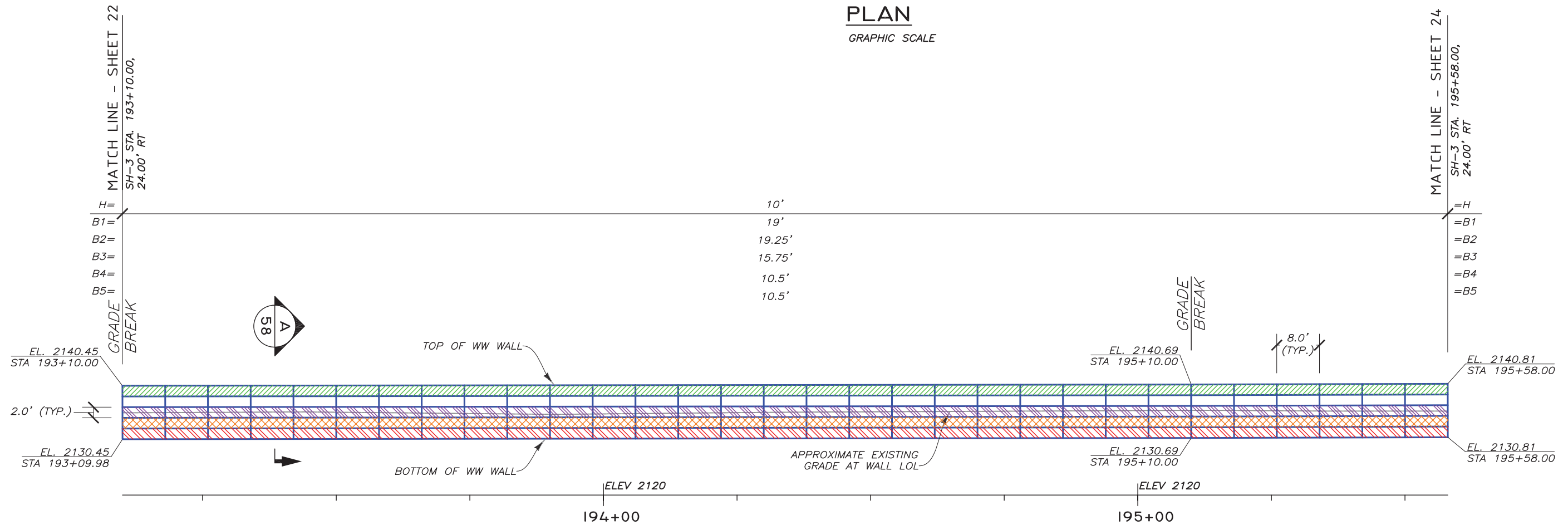

**DEVELOPED ELEVATION - (FRONT FACE)**

GRAPHIC SCALE

**LEGEND**

	B1	8"x12", W7xW3.5-HDG	LOL	LAYOUT LINE
	B2	8"x21", W4.5xW4-HDG	H	WALL HEIGHT (BOTTOM MAT TO CAP MAT)
	B3	8"x21", W4.5xW4-HDG (W/GEOFOAM)	B	MAT LENGTH
	B4	8"x21", W4.5xW4-HDG (W/GEOFOAM)	WW	WELDED WIRE
	B5	8"x21", W4.5xW4-HDG		

03584-SH-3\_Goosehaven\_Rd\_I\_PREP 2-4-2022.dwg  
2/4/2022 10:54 AM  
RVanLeuven

THE DESIGN CONTAINED ON THESE DRAWINGS IS BASED ON INFORMATION PROVIDED BY THE OWNER. ON THE BASIS OF THIS INFORMATION, THE HILFIKER COMPANY HAS DESIGNED, AND IS RESPONSIBLE FOR THE INTERNAL STABILITY OF THE STRUCTURE ONLY. EXTERNAL STABILITY, INCLUDING FOUNDATION AND SLOPE STABILITY, IS THE RESPONSIBILITY OF THE OWNER.

REV.	DATE	BY	DESCRIPTION	CADD:
0	12/30/2021	RGV	ISSUED FOR OWNER REVIEW	RGV
1	2/4/2022	RGV	ISSUED FOR OWNER REVIEW IN RESPONSE TO COMMENTS	DESIGNED: RGV CHECKED: SGC

**HILFIKER RETAINING WALLS**

1902 Hilfiker Lane  
Eureka, CA 95503-5711  
TOLL-FREE 800.762.8962  
PH 707.443.5093 FAX 707.443.2891  
WEB SITE www.hilfiker.com E-MAIL info@hilfiker.com

**AMERICAN GEOTECHNICS**

American Geotechnics  
5260 Chinden Blvd.  
Boise, ID 83714  
(208) 658-8700  
Fax: (208) 658-8703

PLAN & ELEVATION	
WW WALL	
SH-3, GOOSEHAVEN RD. TO ROUND LAKE RD.	
ITD	BENEWAH COUNTY, ID

DWG DATE:	4 FEB 2022
HRW NO.:	210714AW
SHEET	23
OF	61

PROFESSIONAL ENGINEER

2/4/2022

15993

STATE OF IDAHO

RYAN G. VAN LEUVEN

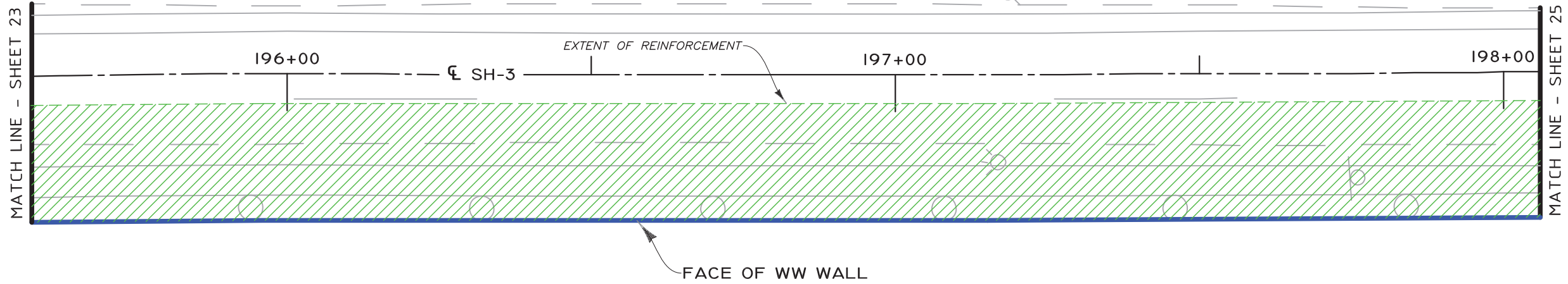
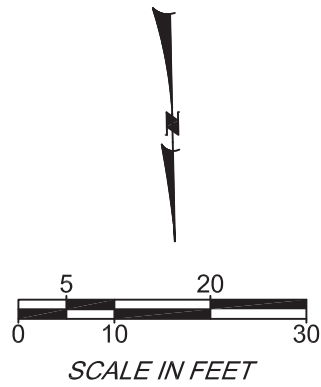

**PLAN**  
GRAPHIC SCALE

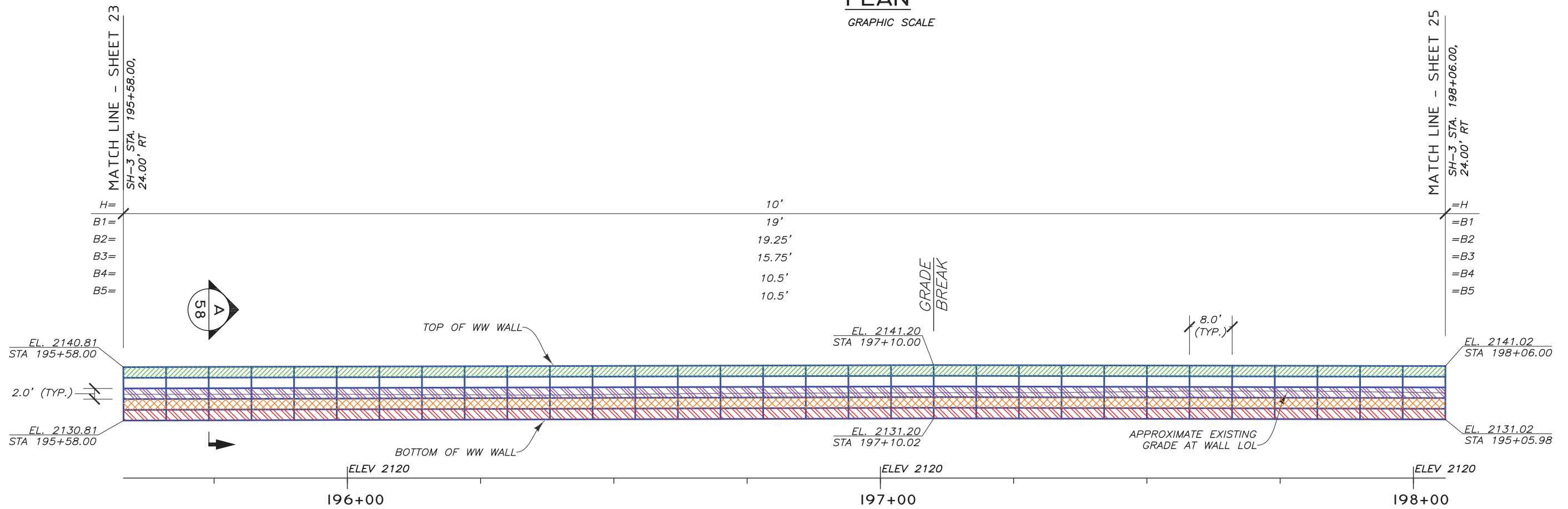

**DEVELOPED ELEVATION - (FRONT FACE)**

GRAPHIC SCALE

**LEGEND**

	B1	8"x12", W7xW3.5-HDG	LOL	LAYOUT LINE
	B2	8"x21", W4.5xW4-HDG	H	WALL HEIGHT (BOTTOM MAT TO CAP MAT)
	B3	8"x21", W4.5xW4-HDG (W/GEOFOAM)	B	MAT LENGTH
	B4	8"x21", W4.5xW4-HDG (W/GEOFOAM)	WW	WELDED WIRE
	B5	8"x21", W4.5xW4-HDG		

03584-SH-3\_Goosehaven\_Rd\_I\_PREP 2-4-2022.dwg

2/4/2022 10:54 AM

REV.	DATE	BY	DESCRIPTION	CADD:
0	12/30/2021	RGV	ISSUED FOR OWNER REVIEW	RGV
1	2/4/2022	RGV	ISSUED FOR OWNER REVIEW IN RESPONSE TO COMMENTS	RGV
				CHECKED: SGC

**HILFIKER RETAINING WALLS**

1902 Hilfiker Lane  
Eureka, CA 95503-5711  
TOLL-FREE 800.752.8962  
PH 707.443.5093 FAX 707.443.2891  
WEB SITE www.hilfiker.com E-MAIL info@hilfiker.com

**AMERICAN GEOTECHNICS**

American Geotechnics  
5260 Chinden Blvd.  
Boise, ID 83714  
(208) 658-8700  
Fax: (208) 658-8703

PLAN & ELEVATION	
WW WALL	
SH-3, GOOSEHAVEN RD. TO ROUND LAKE RD.	
ITD	BENEWAH COUNTY, ID

DWG DATE:	4 FEB 2022
HRW NO.:	210714AW
SHEET	24
OF	61

PROFESSIONAL ENGINEER

2/4/2022

15993

RYAN G. VAN LEUVEN



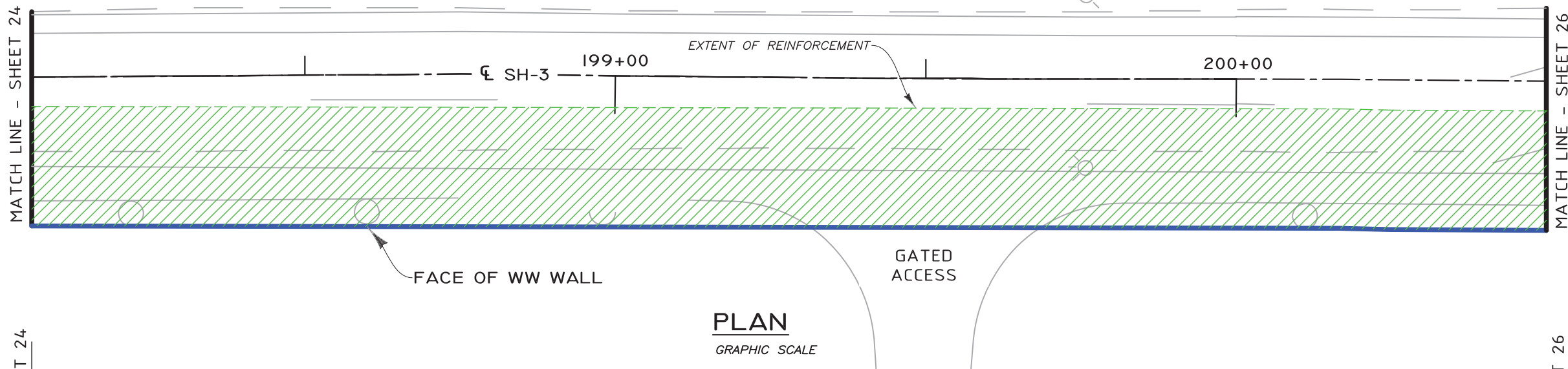
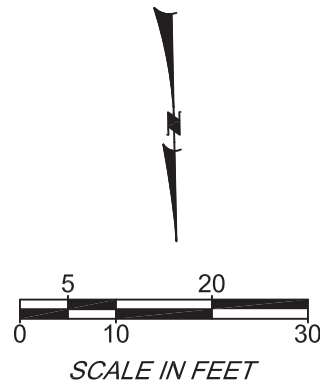

**PLAN**  
GRAPHIC SCALE

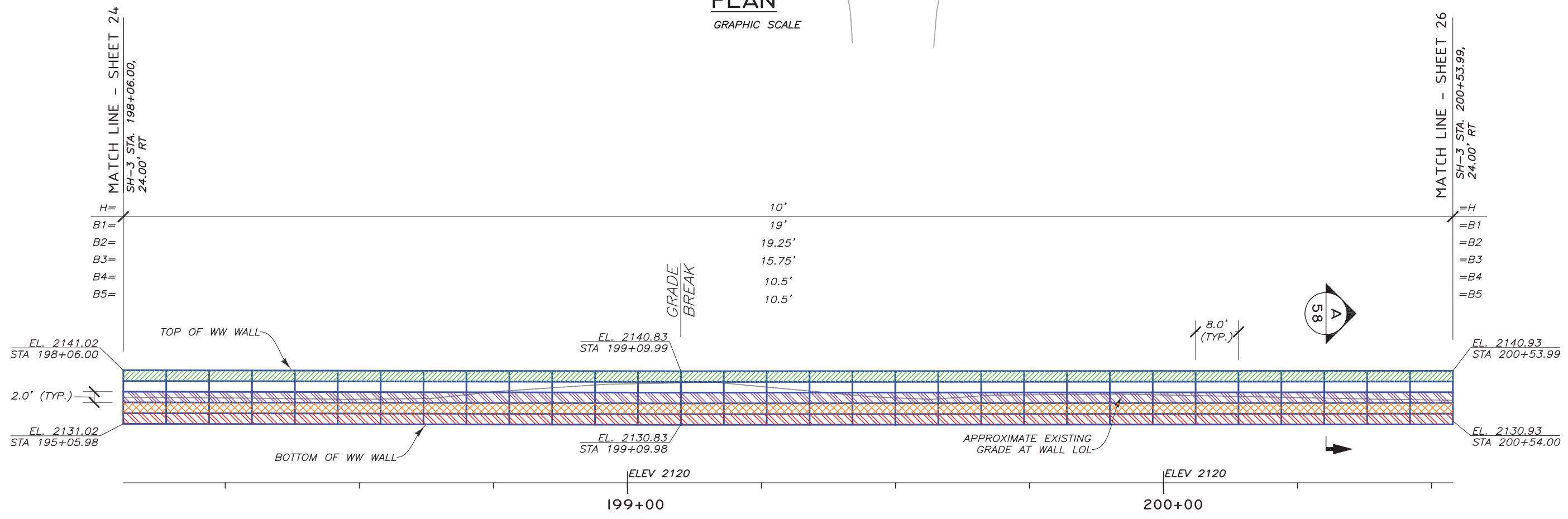

**DEVELOPED ELEVATION - (FRONT FACE)**  
GRAPHIC SCALE

**LEGEND**

	B1	8"x12", W7xW3.5-HDG	LOL	LAYOUT LINE
	B2	8"x21", W4.5xW4-HDG	H	WALL HEIGHT (BOTTOM MAT TO CAP MAT)
	B3	8"x21", W4.5xW4-HDG (W/GEOFOAM)	B	MAT LENGTH
	B4	8"x21", W4.5xW4-HDG (W/GEOFOAM)	WW	WELDED WIRE
	B5	8"x21", W4.5xW4-HDG		

03584-SH-3\_Goosehaven\_Rd\_I1\_PREP\_2-4-2022.dwg

2/4/2022 10:54 AM

REV.	DATE	BY	DESCRIPTION	CADD:
0	12/30/2021	RGV	ISSUED FOR OWNER REVIEW	RGV
1	2/4/2022	RGV	ISSUED FOR OWNER REVIEW IN RESPONSE TO COMMENTS	DESIGNED: RGV CHECKED: SGC

**HILFIKER RETAINING WALLS**

1902 Hilfiker Lane  
Eureka, CA 95503-5711  
TOLL-FREE 800.762.8962  
PH 707.443.5093 FAX 707.443.2891  
WEB SITE www.hilfiker.com E-MAIL info@hilfiker.com

**AMERICAN GEOTECHNICS**

American Geotechnics  
5260 Chinden Blvd.  
Boise, ID 83714  
(208) 658-8700  
Fax: (208) 658-8703

PLAN & ELEVATION  
WW WALL  
SH-3, GOOSEHAVEN RD.  
TO ROUND LAKE RD.  
ITD BENEWAH COUNTY, ID

DWG DATE:  
4 FEB 2022  
HRW NO.:  
210714AW  
SHEET  
25  
OF 61

PROFESSIONAL ENGINEER  
2/4/2022  
15993  
  
ALAN G. VAN LEUVEN  
STATE OF IDAHO

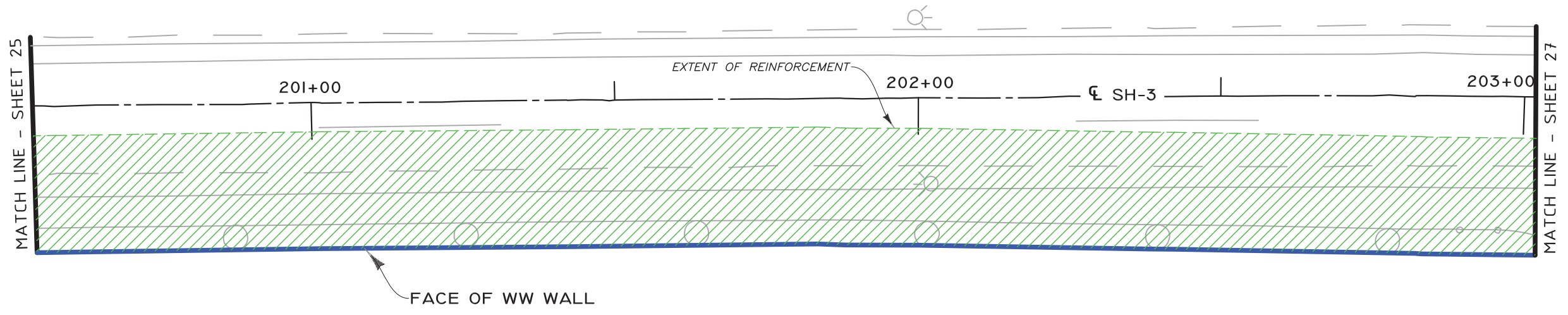
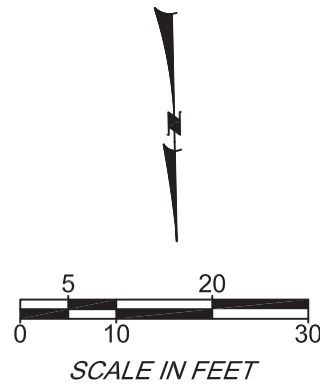

**PLAN**  
GRAPHIC SCALE

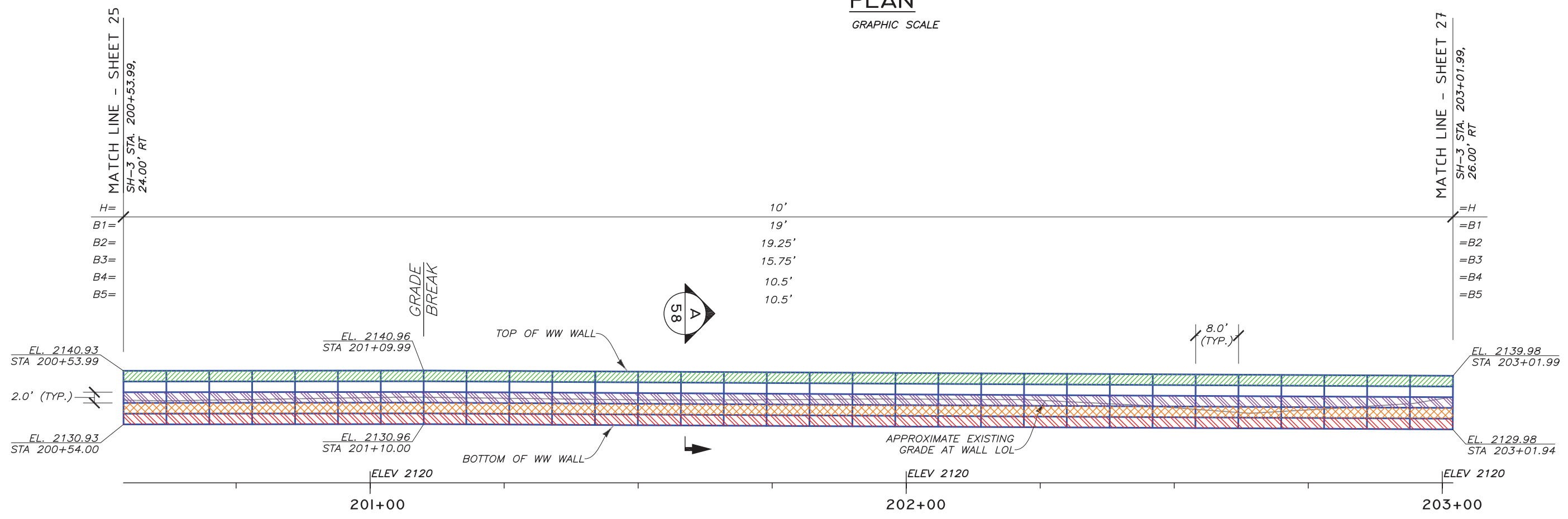

**DEVELOPED ELEVATION - (FRONT FACE)**  
GRAPHIC SCALE

**LEGEND**

	B1	8"x12", W7xW3.5-HDG	LOL	LAYOUT LINE
	B2	8"x21", W4.5xW4-HDG	H	WALL HEIGHT (BOTTOM MAT TO CAP MAT)
	B3	8"x21", W4.5xW4-HDG (W/GEOFOAM)	B	MAT LENGTH
	B4	8"x21", W4.5xW4-HDG (W/GEOFOAM)	WW	WELDED WIRE
	B5	8"x21", W4.5xW4-HDG		

03584-SH-3\_Goosehaven\_Rd\_I\_PREP\_2-4-2022.dwg  
2/4/2022 10:54 AM  
RVanLeuven

REV.	DATE	BY	DESCRIPTION	CADD:
0	12/30/2021	RGV	ISSUED FOR OWNER REVIEW	RGV
1	2/4/2022	RGV	ISSUED FOR OWNER REVIEW IN RESPONSE TO COMMENTS	DESIGNED: RGV
				CHECKED: SGC

**HILFIKER RETAINING WALLS**

1902 Hilfiker Lane  
Eureka, CA 95503-5711  
TOLL-FREE 800.752.8962  
PH 707.443.5093 FAX 707.443.2891  
WEB SITE www.hilfiker.com E-MAIL info@hilfiker.com

**AMERICAN GEOTECHNICS**

American Geotechnics  
5260 Chinden Blvd.  
Boise, ID 83714  
(208) 658-8700  
Fax: (208) 658-8703

PLAN & ELEVATION  
WW WALL  
SH-3, GOOSEHAVEN RD.  
TO ROUND LAKE RD.  
ITD BENEWAH COUNTY, ID

DWG DATE:	4 FEB 2022
HRW NO.:	210714AW
SHEET	26
OF	61

PROFESSIONAL ENGINEER  
2/4/2022  
15993  
R. VAN LEUVEN  
STATE OF IDAHO

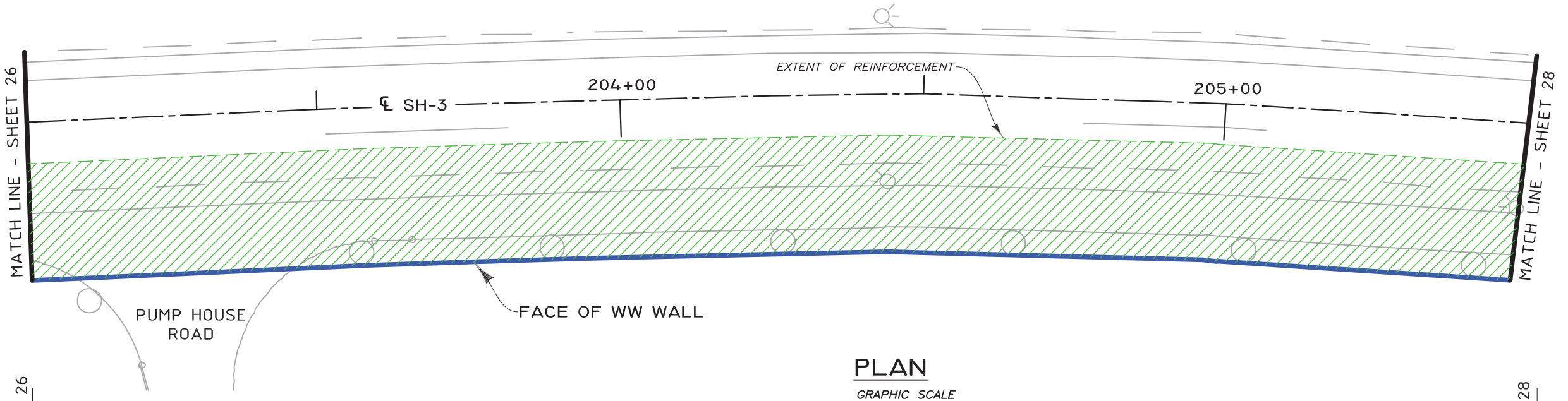
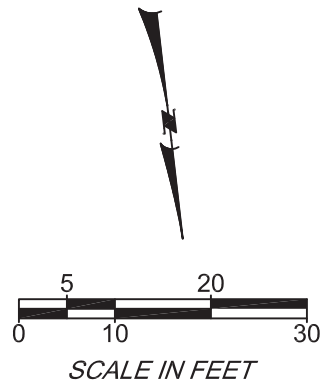

**PLAN**  
GRAPHIC SCALE

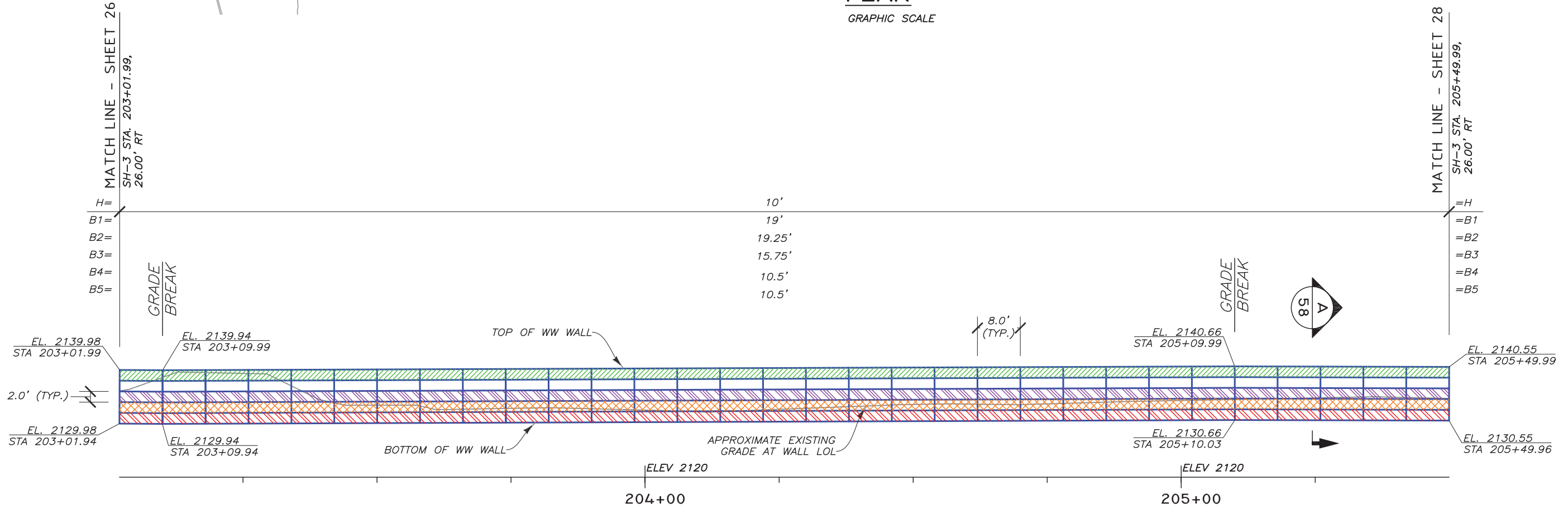

**DEVELOPED ELEVATION - (FRONT FACE)**  
GRAPHIC SCALE

LEGEND			
	B1	8"X12", W7xW3.5-HDG	LOL LAYOUT LINE
	B2	8"X21", W4.5xW4-HDG	H WALL HEIGHT (BOTTOM MAT TO CAP MAT)
	B3	8"X21", W4.5xW4-HDG (W/GEOFOAM)	B MAT LENGTH
	B4	8"X21", W4.5xW4-HDG (W/GEOFOAM)	WW WELDED WIRE
	B5	8"X21", W4.5xW4-HDG	

THE DESIGN CONTAINED ON THESE DRAWINGS IS BASED ON INFORMATION PROVIDED BY THE OWNER. ON THE BASIS OF THIS INFORMATION, THE HILFIKER COMPANY HAS DESIGNED, AND IS RESPONSIBLE FOR THE INTERNAL STABILITY OF THE STRUCTURE ONLY. EXTERNAL STABILITY, INCLUDING FOUNDATION AND SLOPE STABILITY, IS THE RESPONSIBILITY OF THE OWNER.

REV.	DATE	BY	DESCRIPTION
0	12/30/2021	RGV	ISSUED FOR OWNER REVIEW
1	2/4/2022	RGV	ISSUED FOR OWNER REVIEW IN RESPONSE TO COMMENTS
2	2/28/2022	RGV	ISSUED FOR OWNER REVIEW IN RESPONSE TO COMMENTS

CADD: RGV  
DESIGNED: RGV  
CHECKED: SGC

**HILFIKER RETAINING WALLS**  
  
 1902 Hilfiker Lane  
 Eureka, CA 95503-5711  
 TOLL FREE 800.762.8962  
 PH 707.443.5093 FAX 707.443.2891  
 WEBSITE www.hilfiker.com E-MAIL info@hilfiker.com

**AMERICAN GEO TECHNICS**  
  
 American Geotechnics  
 5260 Chinden Blvd.  
 Boise, ID 83714  
 (208) 658-8700  
 Fax: (208) 658-8703

PLAN & ELEVATION  
 WW WALL  
 SH-3, GOOSEHAVEN RD.  
 TO ROUND LAKE RD.  
 ITD BENEWAH COUNTY, ID

DWG DATE: 28 FEB 2022  
 HRW NO.: 210714AW  
 SHEET 27 OF 61

**PROFESSIONAL ENGINEER**  
 2/28/2022  
 15993  
  
 MAN G. VAN LEUVEN  
 STATE OF IDAHO

03584 - SH-3, Goosehaven Rd., ITD PREP 2-28-2022.dwg  
2/28/2022 11:11 AM  
RVanLeuven

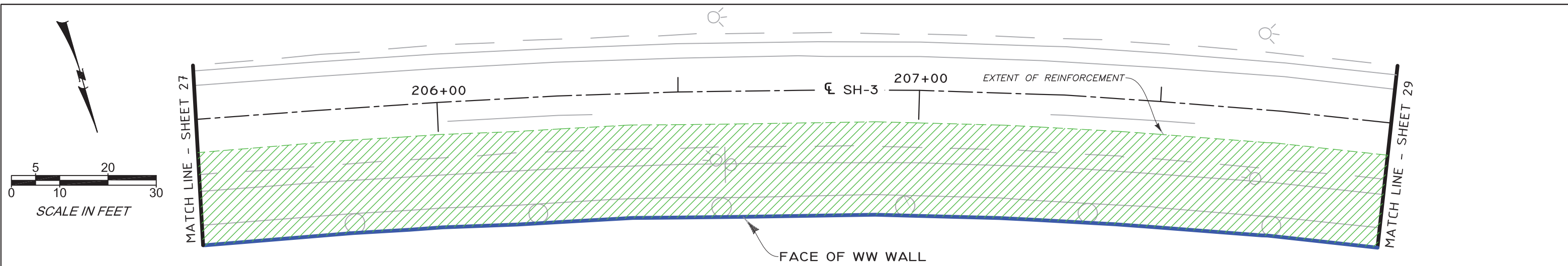

**PLAN**  
GRAPHIC SCALE

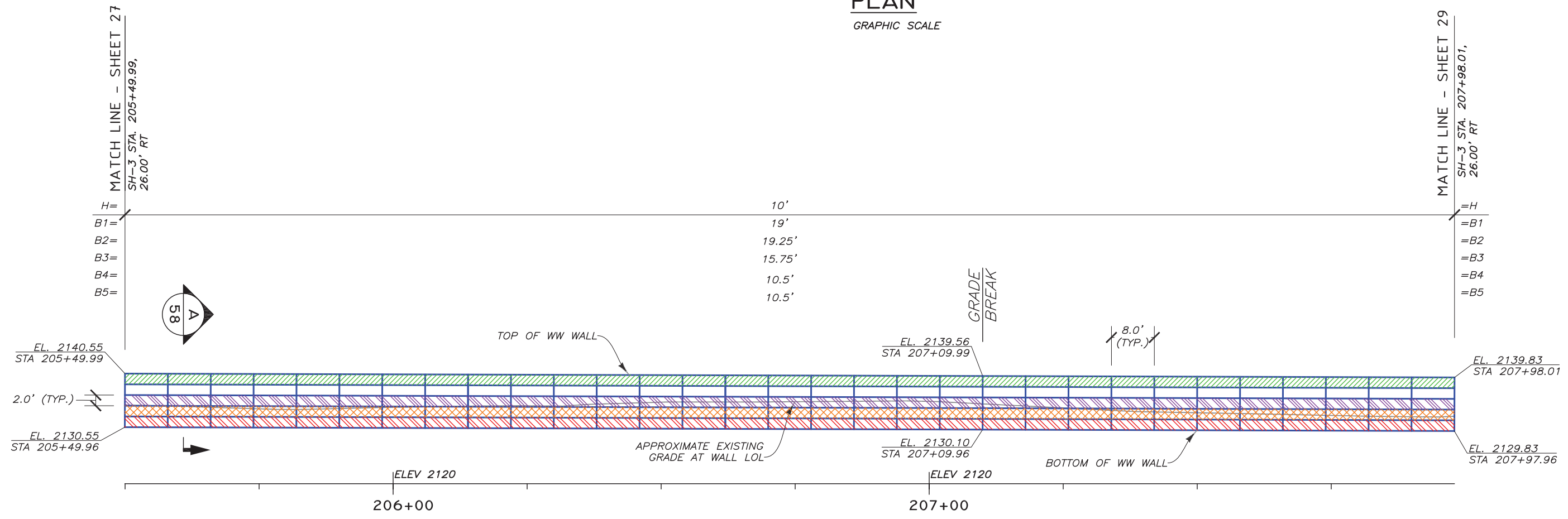

**DEVELOPED ELEVATION - (FRONT FACE)**  
GRAPHIC SCALE

**LEGEND**

	B1	8"X12", W7xW3.5-HDG	LOL	LAYOUT LINE
	B2	8"X21", W4.5xW4-HDG	H	WALL HEIGHT (BOTTOM MAT TO CAP MAT)
	B3	8"X21", W4.5xW4-HDG (W/GEOFOAM)	B	MAT LENGTH
	B4	8"X21", W4.5xW4-HDG (W/GEOFOAM)	WW	WELDED WIRE
	B5	8"X21", W4.5xW4-HDG		

03584 - SH-3, Goosehaven Rd. JT PREP 2-28-2022.dwg  
2/28/2022 11:11 AM  
Ryan G. Van Leuven

REV.	DATE	BY	DESCRIPTION	CADD:
0	12/30/2021	RGV	ISSUED FOR OWNER REVIEW	RGV
1	2/4/2022	RGV	ISSUED FOR OWNER REVIEW IN RESPONSE TO COMMENTS	DESIGNED: RGV
2	2/28/2022	RGV	ISSUED FOR OWNER REVIEW IN RESPONSE TO COMMENTS	CHECKED: SGC

**HILFIKER RETAINING WALLS**

1902 Hilfiker Lane  
Eureka, CA 95503-5711  
TOLL FREE 800.762.8962  
PH 707.443.5093 FAX 707.443.2891  
WEBSITE www.hilfiker.com E-MAIL info@hilfiker.com

**AMERICAN GEOTECHNICS**

American Geotechnics  
5260 Chinden Blvd.  
Boise, ID 83714  
(208) 658-8700  
Fax: (208) 658-8703

PLAN & ELEVATION	DWG DATE: 28 FEB 2022
WW WALL	HRW NO.:
SH-3, GOOSEHAVEN RD. TO ROUND LAKE RD.	210714AW
ITD	SHEET 28 OF 61
BENEWAH COUNTY, ID	

**PROFESSIONAL ENGINEER**

2/28/2022

15993

RYAN G. VAN LEUVEN

STATE OF IDAHO

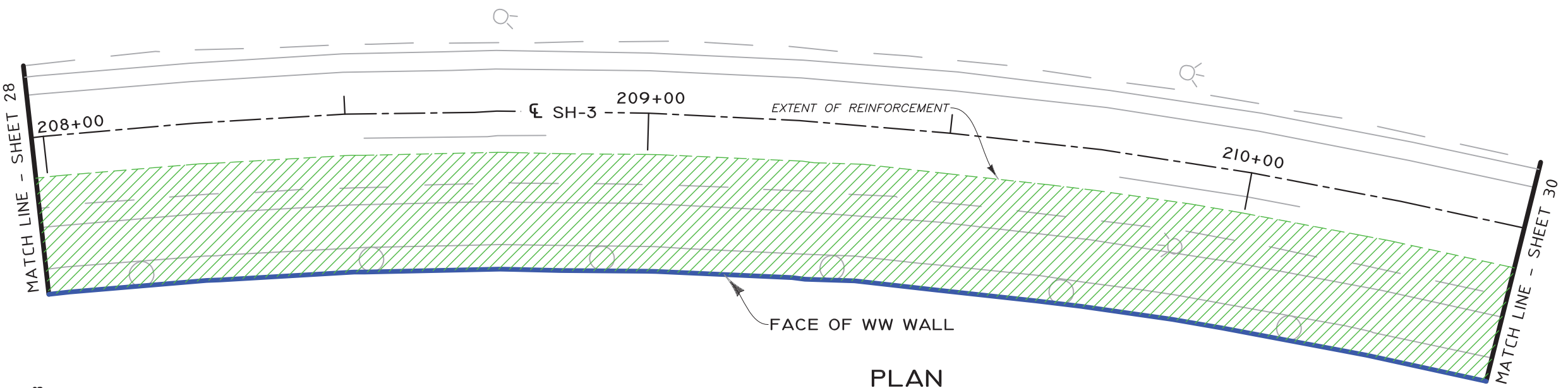
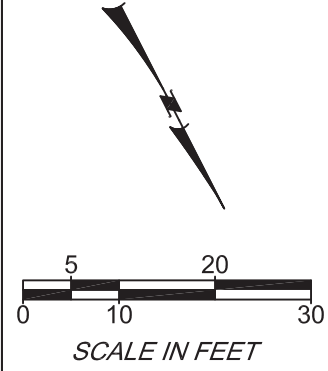

**PLAN**  
GRAPHIC SCALE

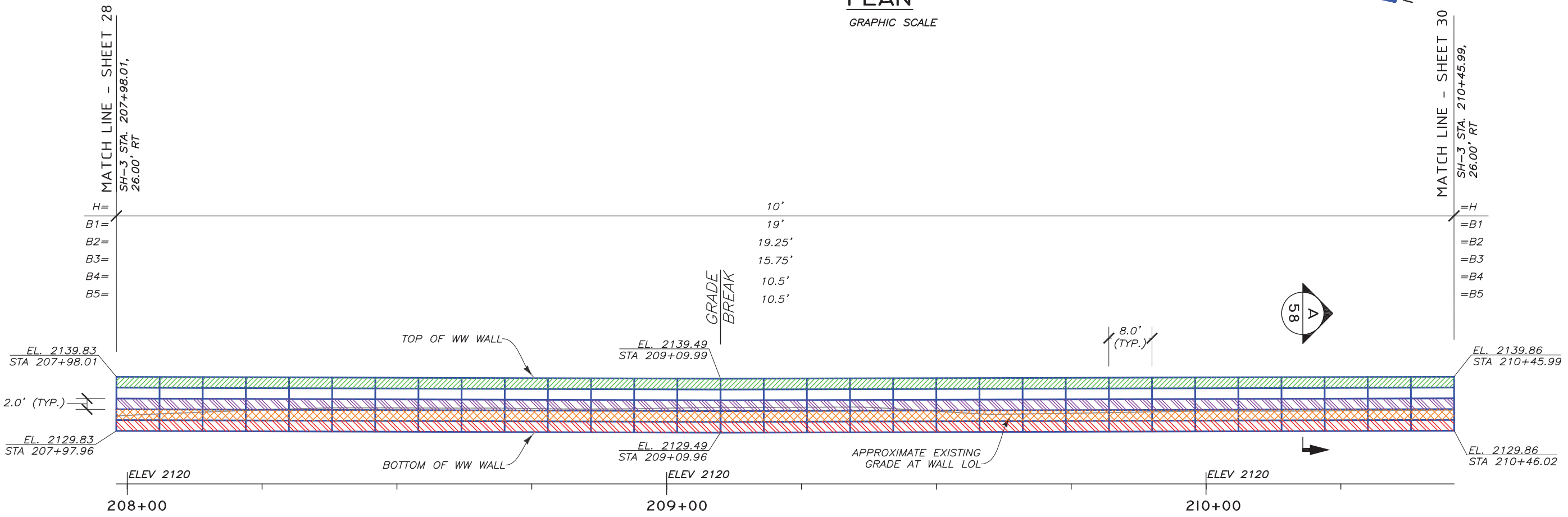

**DEVELOPED ELEVATION - (FRONT FACE)**  
GRAPHIC SCALE

LEGEND			
	B1 8"x12", W7xW3.5-HDG	LOL	LAYOUT LINE
	B2 8"x21", W4.5xW4-HDG	H	WALL HEIGHT (BOTTOM MAT TO CAP MAT)
	B3 8"x21", W4.5xW4-HDG (W/GEOFOAM)	B	MAT LENGTH
	B4 8"x21", W4.5xW4-HDG (W/GEOFOAM)	WW	WELDED WIRE
	B5 8"x21", W4.5xW4-HDG		

03584 - SHEET 3 - Goosehaven Rd. JT PREP 2-28-2022.dwg  
2/28/2022 11:11 AM  
Ryan Leuven

THE DESIGN CONTAINED ON THESE DRAWINGS IS BASED ON INFORMATION PROVIDED BY THE OWNER. ON THE BASIS OF THIS INFORMATION, THE HILFIKER COMPANY HAS DESIGNED, AND IS RESPONSIBLE FOR THE INTERNAL STABILITY OF THE STRUCTURE ONLY. EXTERNAL STABILITY, INCLUDING FOUNDATION AND SLOPE STABILITY, IS THE RESPONSIBILITY OF THE OWNER.

REV.	DATE	BY	DESCRIPTION
0	12/30/2021	RGV	ISSUED FOR OWNER REVIEW
1	2/4/2022	RGV	ISSUED FOR OWNER REVIEW IN RESPONSE TO COMMENTS
2	2/28/2022	RGV	ISSUED FOR OWNER REVIEW IN RESPONSE TO COMMENTS

CADD: RGV  
DESIGNED: RGV  
CHECKED: SGC

**HILFIKER RETAINING WALLS**  
  
 1902 Hilfiker Lane  
 Eureka, CA 95503-5711  
 TOLL FREE 800.762.8962  
 PH 707.443.5093 FAX 707.443.2891  
 WEBSITE www.hilfiker.com E-MAIL info@hilfiker.com

**AMERICAN GEOTECHNICS**  
  
 American Geotechnics  
 5260 Chinden Blvd.  
 Boise, ID 83714  
 (208) 658-8700  
 Fax: (208) 658-8703

PLAN & ELEVATION	DWG DATE: 28 FEB 2022
WW WALL	HRW NO.: 210714AW
SH-3, GOOSEHAVEN RD. TO ROUND LAKE RD.	SHEET 29 OF 61
ITD	BENEWAH COUNTY, ID

**PROFESSIONAL ENGINEER**  
 2/28/2022  
 15993  
  
 RYAN G. VAN LEUVEN

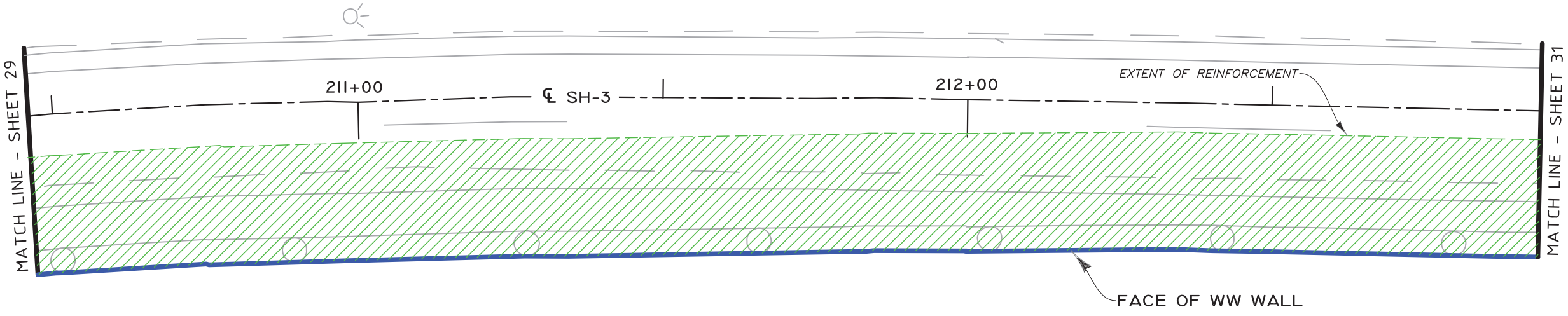
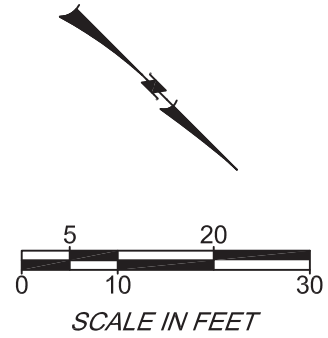

**PLAN**  
GRAPHIC SCALE

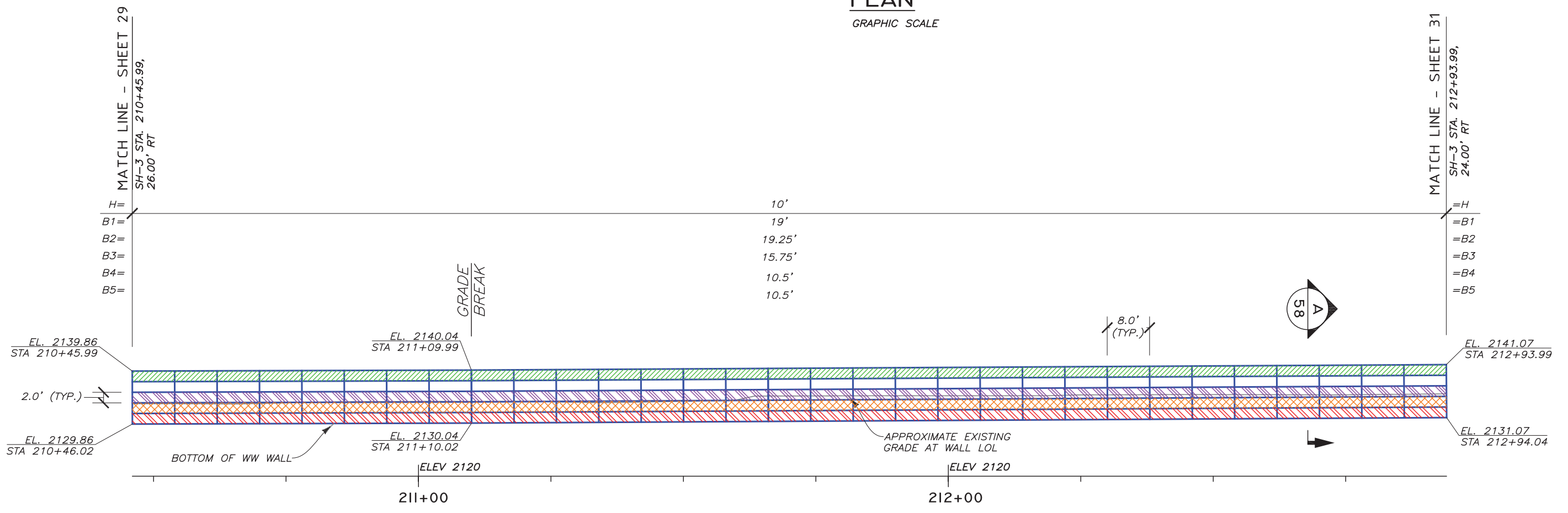

**DEVELOPED ELEVATION - (FRONT FACE)**  
GRAPHIC SCALE

**LEGEND**

	B1	8"x12", W7xW3.5-HDG	LOL	LAYOUT LINE
	B2	8"x21", W4.5xW4-HDG	H	WALL HEIGHT (BOTTOM MAT TO CAP MAT)
	B3	8"x21", W4.5xW4-HDG (W/GEOFOAM)	B	MAT LENGTH
	B4	8"x21", W4.5xW4-HDG (W/GEOFOAM)	WW	WELDED WIRE
	B5	8"x21", W4.5xW4-HDG		

THE DESIGN CONTAINED ON THESE DRAWINGS IS BASED ON INFORMATION PROVIDED BY THE OWNER. ON THE BASIS OF THIS INFORMATION, THE HILFIKER COMPANY HAS DESIGNED, AND IS RESPONSIBLE FOR THE INTERNAL STABILITY OF THE STRUCTURE ONLY. EXTERNAL STABILITY, INCLUDING FOUNDATION AND SLOPE STABILITY, IS THE RESPONSIBILITY OF THE OWNER.

REV.	DATE	BY	DESCRIPTION
0	12/30/2021	RGV	ISSUED FOR OWNER REVIEW
1	2/4/2022	RGV	ISSUED FOR OWNER REVIEW IN RESPONSE TO COMMENTS

CADD: RGV  
DESIGNED: RGV  
CHECKED: SGC

**HILFIKER RETAINING WALLS**

1902 Hilfiker Lane  
Eureka, CA 95503-5711  
TOLL-FREE 800.752.8962  
PH 707.443.5093 FAX 707.443.2891  
WEB SITE www.hilfiker.com E-MAIL info@hilfiker.com

**AMERICAN GEOTECHNICS**

American Geotechnics  
5260 Chinden Blvd.  
Boise, ID 83714  
(208) 658-8700  
Fax: (208) 658-8703

PLAN & ELEVATION	DWG DATE: 4 FEB 2022
WW WALL	HRW NO.: 210714AW
SH-3, GOOSEHAVEN RD. TO ROUND LAKE RD.	SHEET 30 OF 61
ITD BENEWAH COUNTY, ID	

PROFESSIONAL ENGINEER  
2/4/2022  
15993  
N. G. VAN LEUVEN  
STATE OF IDAHO

03584-SH-3\_Goosehaven\_Rd\_ID\_PREP\_2-4-2022.dwg  
2/4/2022 10:54 AM  
RVanLeuven

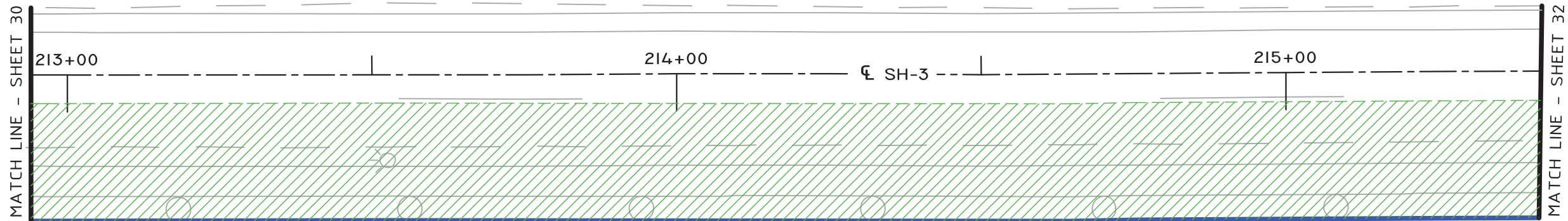
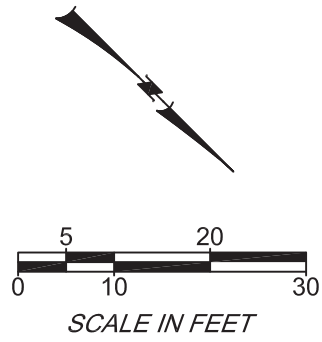

**PLAN**  
GRAPHIC SCALE

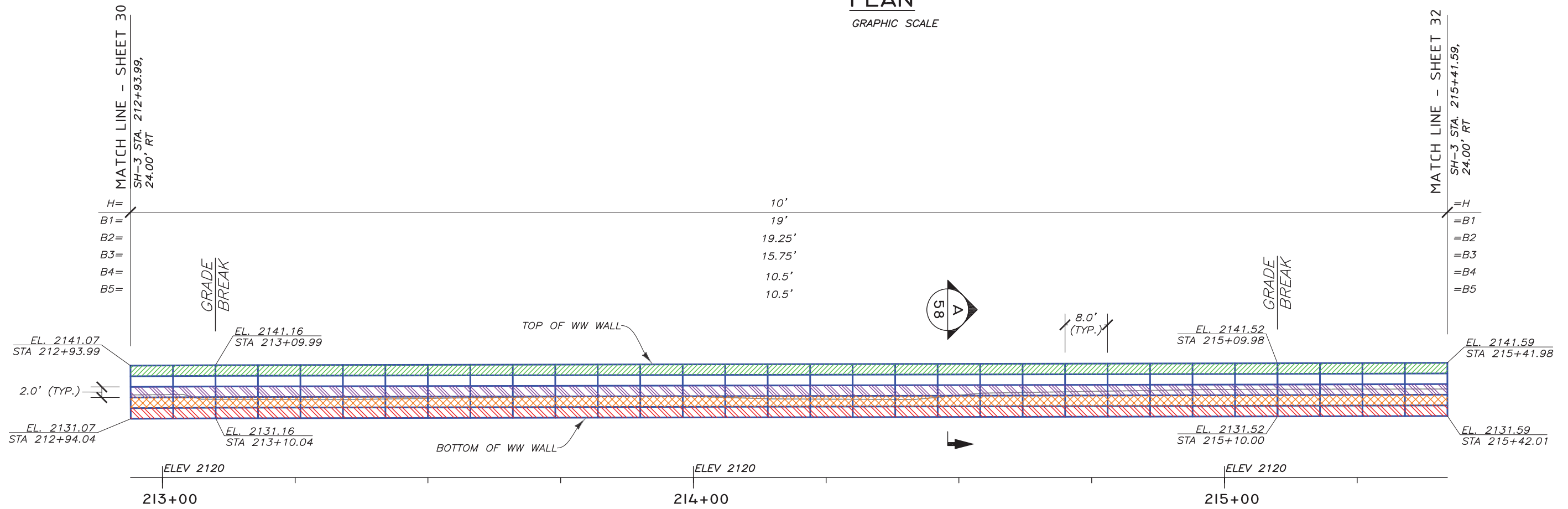

**DEVELOPED ELEVATION - (FRONT FACE)**

GRAPHIC SCALE

**LEGEND**

	B1	8"X12", W7xW3.5-HDG	LOL	LAYOUT LINE
	B2	8"X21", W4.5xW4-HDG	H	WALL HEIGHT (BOTTOM MAT TO CAP MAT)
	B3	8"X21", W4.5xW4-HDG (W/GEOFOAM)	B	MAT LENGTH
	B4	8"X21", W4.5xW4-HDG (W/GEOFOAM)	WW	WELDED WIRE
	B5	8"X21", W4.5xW4-HDG		

03584-SH-3\_Goosehaven\_Rd\_11\_PREP 2-4-2022.dwg

2/4/2022 10:54 AM

THE DESIGN CONTAINED ON THESE DRAWINGS IS BASED ON INFORMATION PROVIDED BY THE OWNER. ON THE BASIS OF THIS INFORMATION, THE HILFIKER COMPANY HAS DESIGNED, AND IS RESPONSIBLE FOR THE INTERNAL STABILITY OF THE STRUCTURE ONLY. EXTERNAL STABILITY, INCLUDING FOUNDATION AND SLOPE STABILITY, IS THE RESPONSIBILITY OF THE OWNER.

REV.	DATE	BY	DESCRIPTION
0	12/30/2021	RGV	ISSUED FOR OWNER REVIEW
1	2/4/2022	RGV	ISSUED FOR OWNER REVIEW IN RESPONSE TO COMMENTS

CADD:	RGV
DESIGNED:	RGV
CHECKED:	SGC

**HILFIKER RETAINING WALLS**

1902 Hilfiker Lane  
Eureka, CA 95503-5711  
TOLL-FREE 800.752.8962  
PH 707.443.5093 FAX 707.443.2891  
WEB SITE www.hilfiker.com EMAIL info@hilfiker.com

**AMERICAN GEOTECHNICS**

American Geotechnics  
5260 Chinden Blvd.  
Boise, ID 83714  
(208) 658-8700  
Fax: (208) 658-8703

PLAN & ELEVATION
WW WALL
SH-3, GOOSEHAVEN RD. TO ROUND LAKE RD.
ITD BENEWAH COUNTY, ID

DWG DATE:	4 FEB 2022
HRW NO.:	210714AW
SHEET	31
OF	61

PROFESSIONAL ENGINEER

2/4/2022

15993

STATE OF IDAHO

A. G. VAN LEUVEN

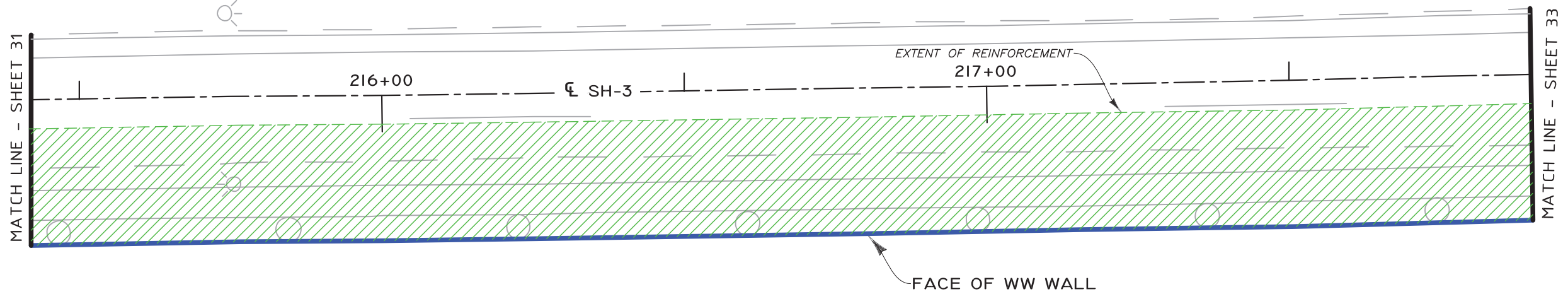
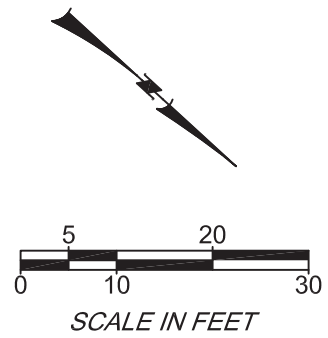

**PLAN**  
GRAPHIC SCALE

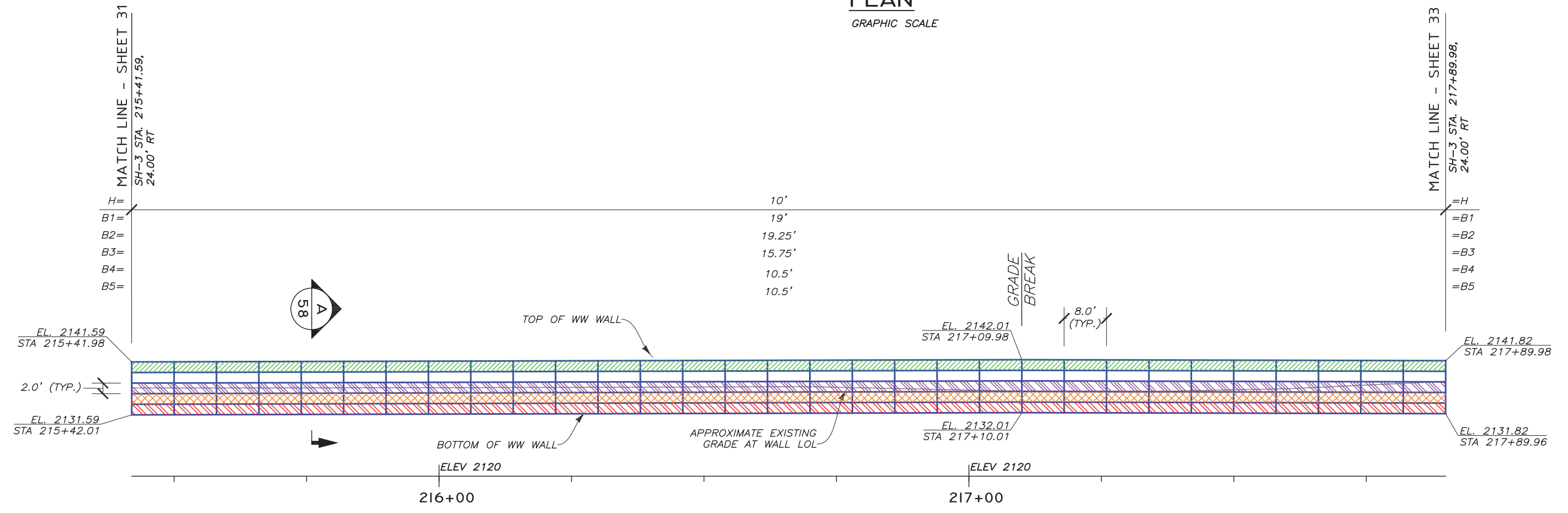

**DEVELOPED ELEVATION - (FRONT FACE)**  
GRAPHIC SCALE

**LEGEND**

	B1	8"x12", W7xW3.5-HDG	LOL	LAYOUT LINE
	B2	8"x21", W4.5xW4-HDG	H	WALL HEIGHT (BOTTOM MAT TO CAP MAT)
	B3	8"x21", W4.5xW4-HDG (W/GEOFOAM)	B	MAT LENGTH
	B4	8"x21", W4.5xW4-HDG (W/GEOFOAM)	WW	WELDED WIRE
	B5	8"x21", W4.5xW4-HDG		

THE DESIGN CONTAINED ON THESE DRAWINGS IS BASED ON INFORMATION PROVIDED BY THE OWNER. ON THE BASIS OF THIS INFORMATION, THE HILFIKER COMPANY HAS DESIGNED, AND IS RESPONSIBLE FOR THE INTERNAL STABILITY OF THE STRUCTURE ONLY. EXTERNAL STABILITY, INCLUDING FOUNDATION AND SLOPE STABILITY, IS THE RESPONSIBILITY OF THE OWNER.

REV.	DATE	BY	DESCRIPTION
0	12/30/2021	RGV	ISSUED FOR OWNER REVIEW
1	2/4/2022	RGV	ISSUED FOR OWNER REVIEW IN RESPONSE TO COMMENTS

CADD:	RGV
DESIGNED:	RGV
CHECKED:	SGC

**HILFIKER RETAINING WALLS**

1902 HilfiKER Lane  
Eureka, CA 95503-5711  
TOLL-FREE 800.752.8962  
PH 707.443.5093 FAX 707.443.2891  
WEB SITE www.hilfiKER.com E-MAIL info@hilfiKER.com

**AMERICAN GEOTECHNICS**

American Geotechnics  
5260 Chinden Blvd.  
Boise, ID 83714  
(208) 658-8700  
Fax: (208) 658-8703

PLAN & ELEVATION	
WW WALL	
SH-3, GOOSEHAVEN RD. TO ROUND LAKE RD.	
ITD	BENEWAH COUNTY, ID

DWG DATE:	4 FEB 2022
HRW NO.:	210714AW
SHEET	32
OF	61

PROFESSIONAL ENGINEER  
2/4/2022  
15993  
  
ALAN G. VAN LEUVEN  
STATE OF IDAHO

03584-SH-3\_Goosehaven\_Rd\_ID\_PREP\_2-4-2022.dwg  
2/4/2022 10:54 AM  
RVanLeuven



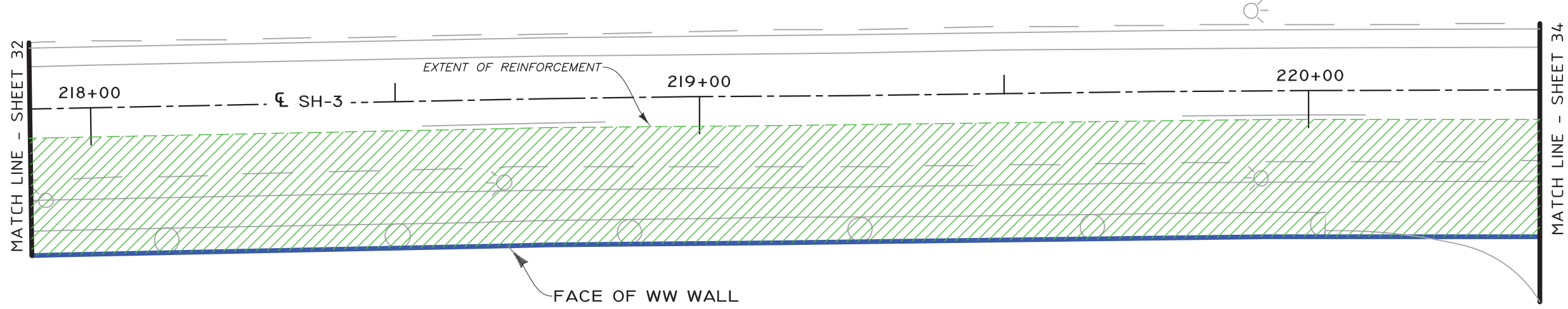
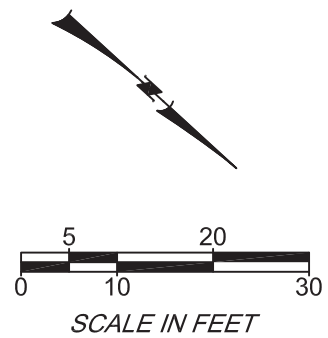

**PLAN**  
GRAPHIC SCALE

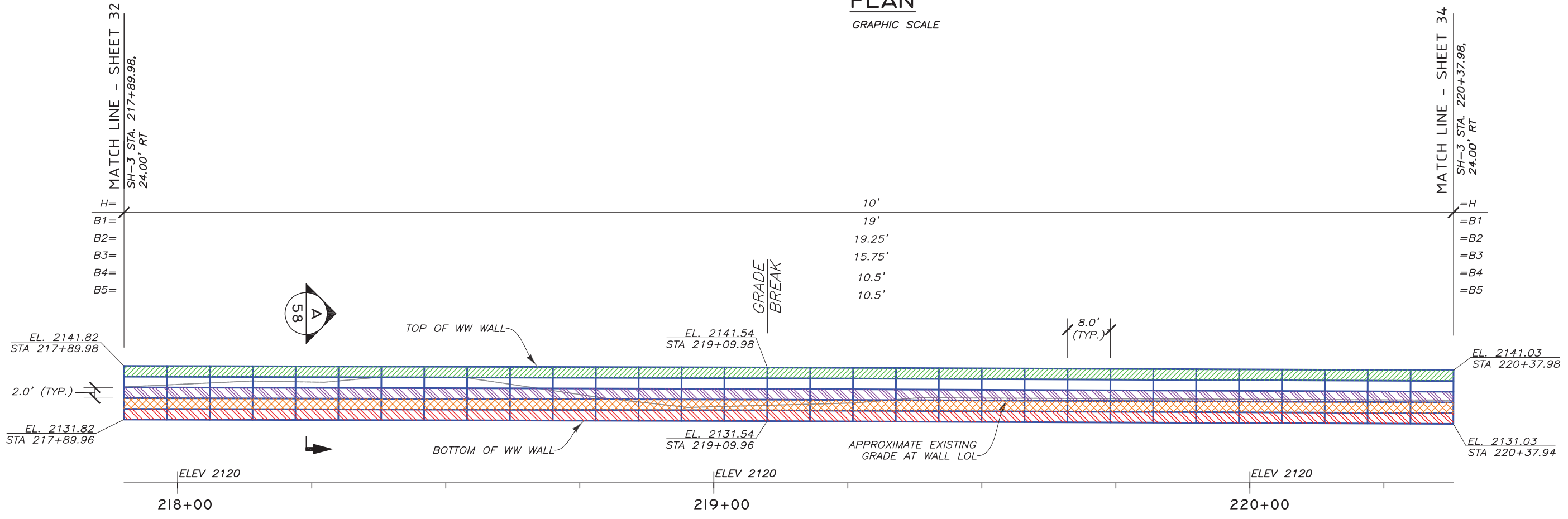

**DEVELOPED ELEVATION - (FRONT FACE)**  
GRAPHIC SCALE

**LEGEND**

	B1	8"x12", W7xW3.5-HDG	LOL	LAYOUT LINE
	B2	8"x21", W4.5xW4-HDG	H	WALL HEIGHT (BOTTOM MAT TO CAP MAT)
	B3	8"x21", W4.5xW4-HDG (W/GEOFOAM)	B	MAT LENGTH
	B4	8"x21", W4.5xW4-HDG (W/GEOFOAM)	WW	WELDED WIRE
	B5	8"x21", W4.5xW4-HDG		

03584-SH-3\_Goosehaven\_Rd\_I1\_PREP\_2-4-2022.dwg  
2/4/2022 10:54 AM  
RVanLeuven

REV.	DATE	BY	DESCRIPTION	CADD:
0	12/30/2021	RGV	ISSUED FOR OWNER REVIEW	RGV
1	2/4/2022	RGV	ISSUED FOR OWNER REVIEW IN RESPONSE TO COMMENTS	RGV
				CHECKED: SGC

**HILFIKER RETAINING WALLS**

1902 HilfiKER Lane  
Eureka, CA 95503-5711  
TOLL-FREE 800.752.8962  
PH 707.443.5093 FAX 707.443.2891  
WEB SITE www.hilfiKER.com E-MAIL info@hilfiKER.com

**AMERICAN GEOTECHNICS**

American Geotechnics  
5260 Chinden Blvd.  
Boise, ID 83714  
(208) 658-8700  
Fax: (208) 658-8703

PLAN & ELEVATION	DWG DATE: 4 FEB 2022
WW WALL	HRW NO.: 210714AW
SH-3, GOOSEHAVEN RD. TO ROUND LAKE RD.	SHEET 33 OF 61
ITD BENEWAH COUNTY, ID	

PROFESSIONAL ENGINEER  
2/4/2022  
15993  
STATE OF IDAHO  
AN G. VAN LEUVEN

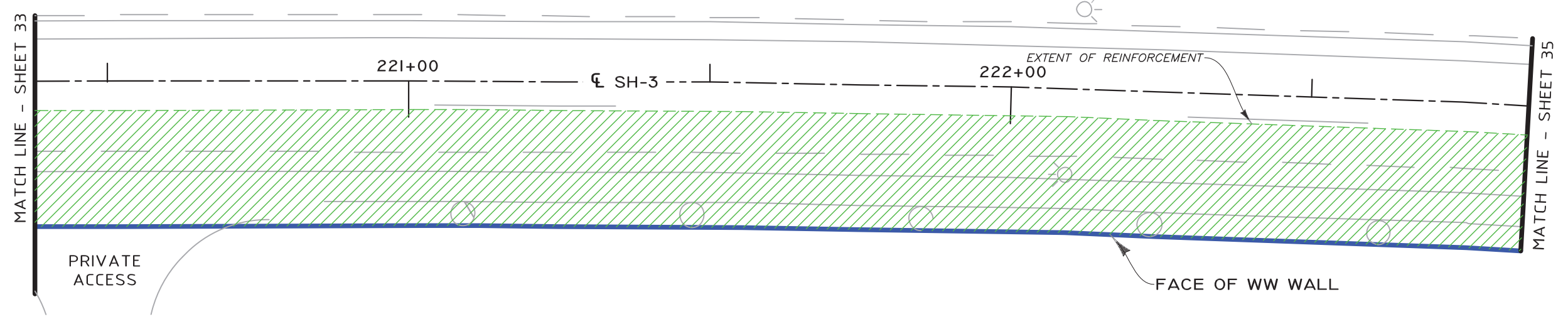
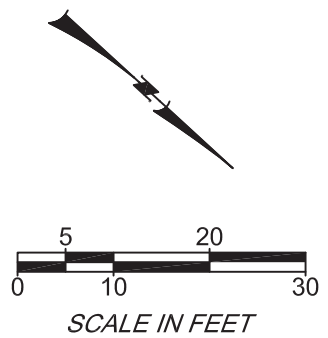

**PLAN**  
GRAPHIC SCALE

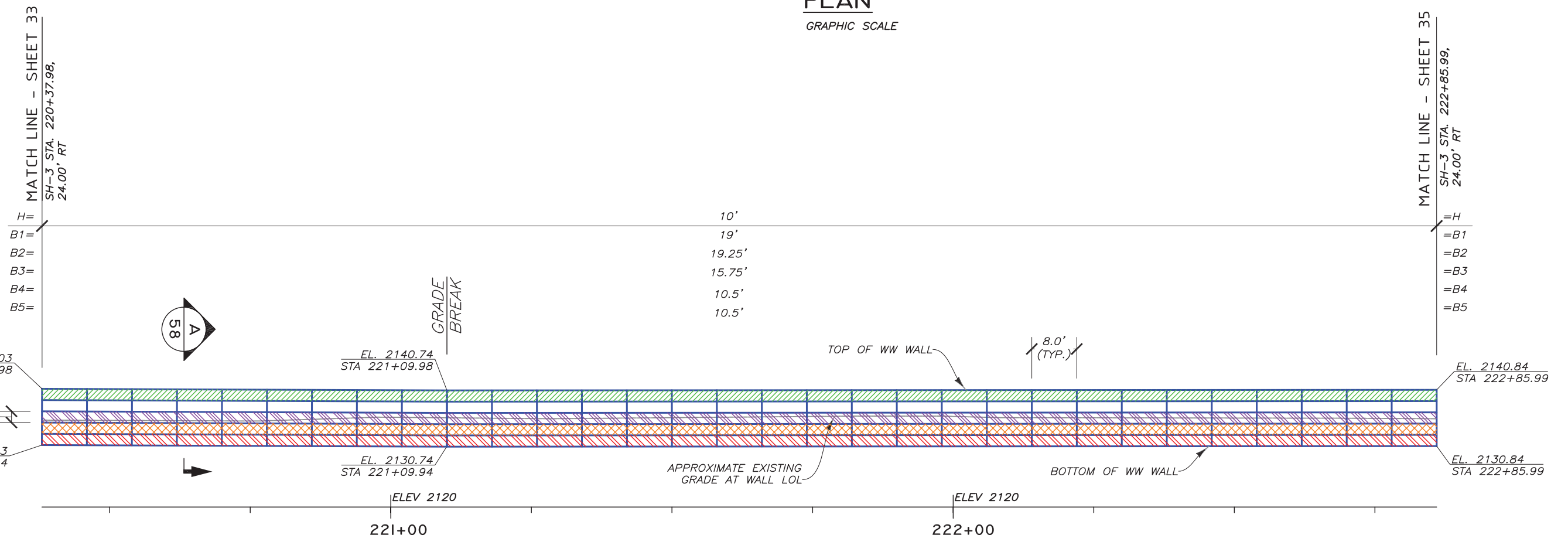

**DEVELOPED ELEVATION - (FRONT FACE)**  
GRAPHIC SCALE

**LEGEND**

	B1	8"x12", W7xW3.5-HDG	LOL	LAYOUT LINE
	B2	8"x21", W4.5xW4-HDG	H	WALL HEIGHT (BOTTOM MAT TO CAP MAT)
	B3	8"x21", W4.5xW4-HDG (W/GEOFOAM)	B	MAT LENGTH
	B4	8"x21", W4.5xW4-HDG (W/GEOFOAM)	WW	WELDED WIRE
	B5	8"x21", W4.5xW4-HDG		

03584-SH-3\_Goosehaven\_Rd\_I1\_PREP\_2-4-2022.dwg  
2/4/2022 10:54 AM  
RVanLeuven

REV.	DATE	BY	DESCRIPTION	CADD:
0	12/30/2021	RGV	ISSUED FOR OWNER REVIEW	RGV
1	2/4/2022	RGV	ISSUED FOR OWNER REVIEW IN RESPONSE TO COMMENTS	DESIGNED: RGV CHECKED: SGC

**HILFIKER RETAINING WALLS**

1902 Hilfiker Lane  
Eureka, CA 95503-5711  
TOLL-FREE 800.762.8962  
PH 707.443.5093 FAX 707.443.2891  
WEB SITE www.hilfiker.com E-MAIL info@hilfiker.com

**AMERICAN GEOTECHNICS**

American Geotechnics  
5260 Chinden Blvd.  
Boise, ID 83714  
(208) 658-8700  
Fax: (208) 658-8703

PLAN & ELEVATION	DWG DATE: 4 FEB 2022
WW WALL	HRW NO.:
SH-3, GOOSEHAVEN RD. TO ROUND LAKE RD.	210714AW
ITD	SHEET
BENEWAH COUNTY, ID	34
	OF 61

PROFESSIONAL ENGINEER

2/4/2022

15993

RYAN G. VAN LEUVEN

STATE OF IDAHO

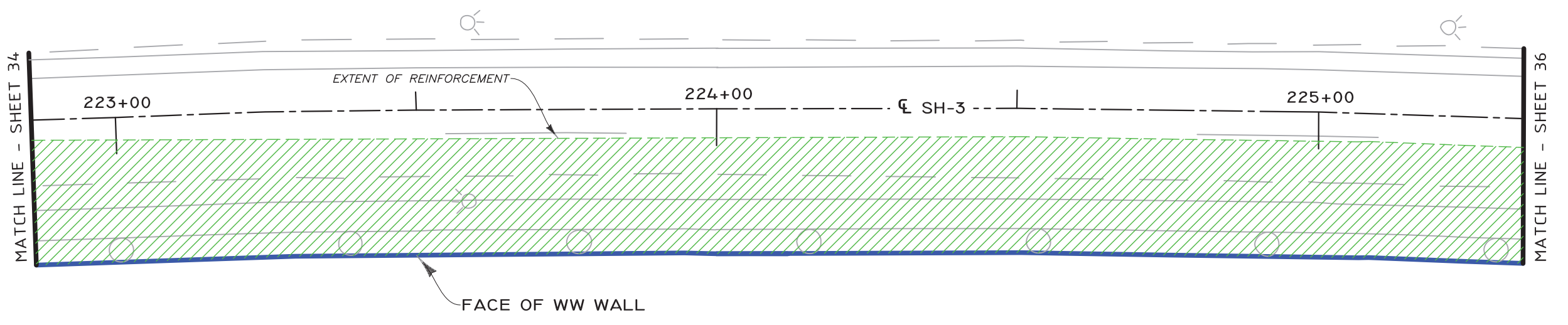
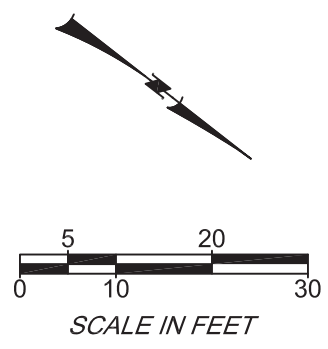

**PLAN**  
GRAPHIC SCALE

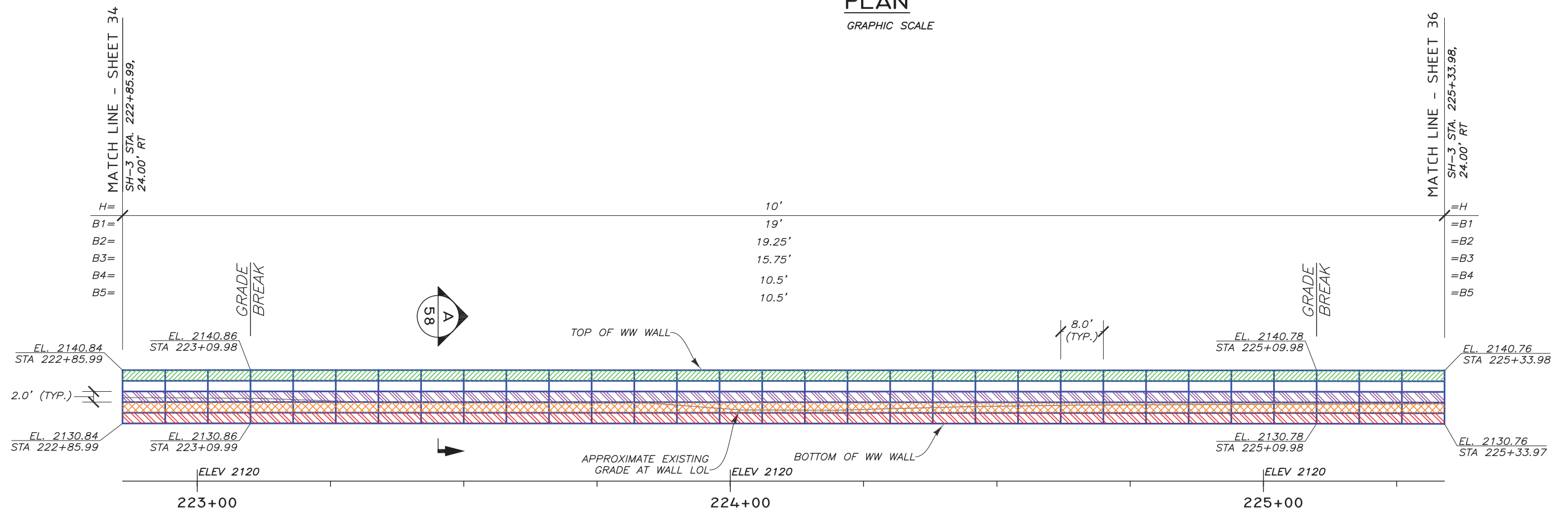

**DEVELOPED ELEVATION - (FRONT FACE)**  
GRAPHIC SCALE

**LEGEND**

	B1	8"x12", W7xW3.5-HDG	LOL	LAYOUT LINE
	B2	8"x21", W4.5xW4-HDG	H	WALL HEIGHT (BOTTOM MAT TO CAP MAT)
	B3	8"x21", W4.5xW4-HDG (W/GEOFOAM)	B	MAT LENGTH
	B4	8"x21", W4.5xW4-HDG (W/GEOFOAM)	WW	WELDED WIRE
	B5	8"x21", W4.5xW4-HDG		

03584-SH-3\_Goosehaven\_Rd\_ID PREP 2-4-2022.dwg  
2/4/2022 10:54 AM  
RVanLeuven

REV.	DATE	BY	DESCRIPTION	CADD:
0	12/30/2021	RGV	ISSUED FOR OWNER REVIEW	RGV
1	2/4/2022	RGV	ISSUED FOR OWNER REVIEW IN RESPONSE TO COMMENTS	DESIGNED: RGV
				CHECKED: SGC

**HILFIKER RETAINING WALLS**

1902 Hilfiker Lane  
Eureka, CA 95503-5711  
TOLL-FREE 800.762.8962  
PH 707.443.5093 FAX 707.443.2891  
WEB SITE www.hilfiker.com EMAIL info@hilfiker.com

**AMERICAN GEOTECHNICS**

American Geotechnics  
5260 Chinden Blvd.  
Boise, ID 83714  
(208) 658-8700  
Fax: (208) 658-8703

PLAN & ELEVATION	DWG DATE: 4 FEB 2022
WW WALL	HRW NO.: 210714AW
SH-3, GOOSEHAVEN RD. TO ROUND LAKE RD.	SHEET 35
ITD BENEWAH COUNTY, ID	OF 61

PROFESSIONAL ENGINEER  
2/4/2022  
15993  
STATE OF IDAHO  
G. VAN LEUVEN

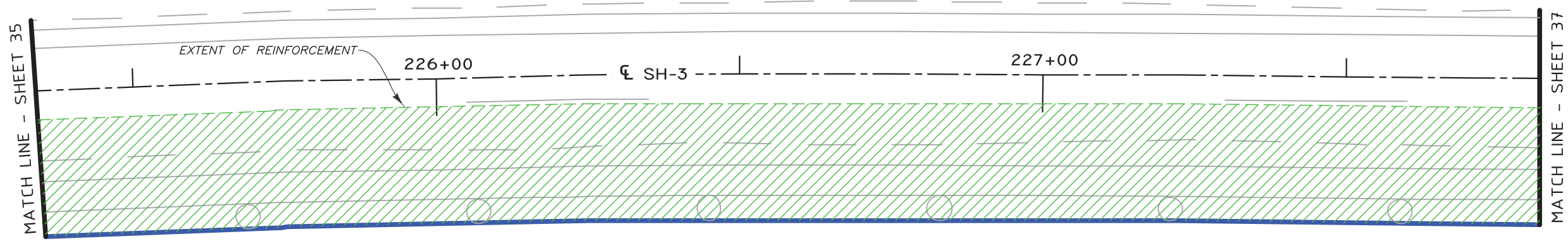
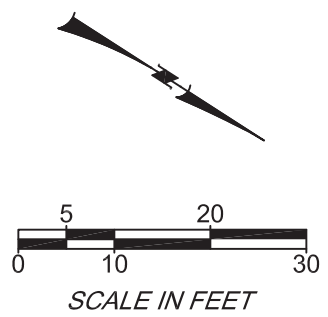

**PLAN**  
GRAPHIC SCALE

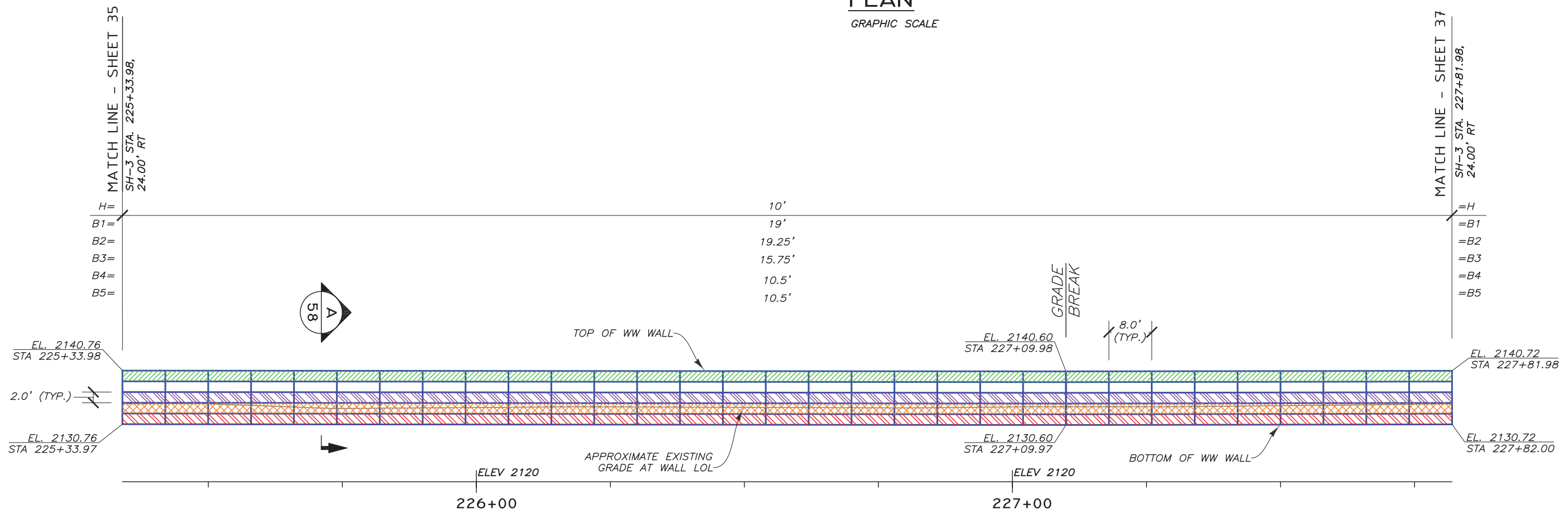

**DEVELOPED ELEVATION - (FRONT FACE)**  
GRAPHIC SCALE

**LEGEND**

	B1	8"x12", W7xW3.5-HDG	LOL	LAYOUT LINE
	B2	8"x21", W4.5xW4-HDG	H	WALL HEIGHT (BOTTOM MAT TO CAP MAT)
	B3	8"x21", W4.5xW4-HDG (W/GEOFOAM)	B	MAT LENGTH
	B4	8"x21", W4.5xW4-HDG (W/GEOFOAM)	WW	WELDED WIRE
	B5	8"x21", W4.5xW4-HDG		

03584-SH-3\_Goosehaven\_Rd\_I1\_PREP 2-4-2022.dwg  
2/4/2022 10:54 AM  
RVanLeuven

REV.	DATE	BY	DESCRIPTION	CADD:
0	12/30/2021	RGV	ISSUED FOR OWNER REVIEW	RGV
1	2/4/2022	RGV	ISSUED FOR OWNER REVIEW IN RESPONSE TO COMMENTS	DESIGNED: RGV CHECKED: SGC

**HILFIKER RETAINING WALLS**

1902 Hilfiker Lane  
Eureka, CA 95503-5711  
TOLL-FREE 800.762.8962  
PH 707.443.5093 FAX 707.443.2891  
WEB SITE www.hilfiker.com E-MAIL info@hilfiker.com

**AMERICAN GEOTECHNICS**

American Geotechnics  
5260 Chinden Blvd.  
Boise, ID 83714  
(208) 658-8700  
Fax: (208) 658-8703

PLAN & ELEVATION	DWG DATE: 4 FEB 2022
WW WALL	HRW NO.: 210714AW
SH-3, GOOSEHAVEN RD. TO ROUND LAKE RD.	SHEET 36
ITD BENEWAH COUNTY, ID	OF 61

PROFESSIONAL ENGINEER  
2/4/2022  
15993  
MAN G. VAN LEUVEN  
STATE OF IDAHO

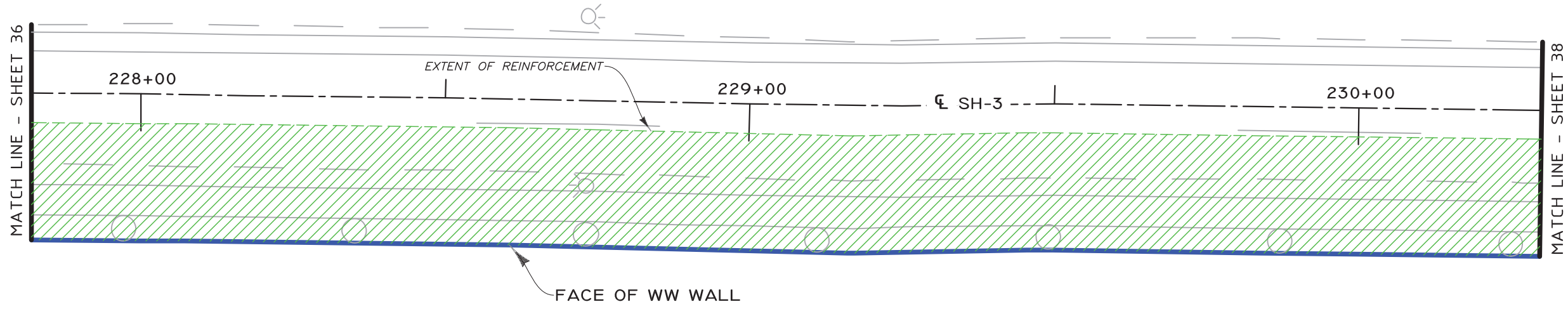

**PLAN**  
GRAPHIC SCALE

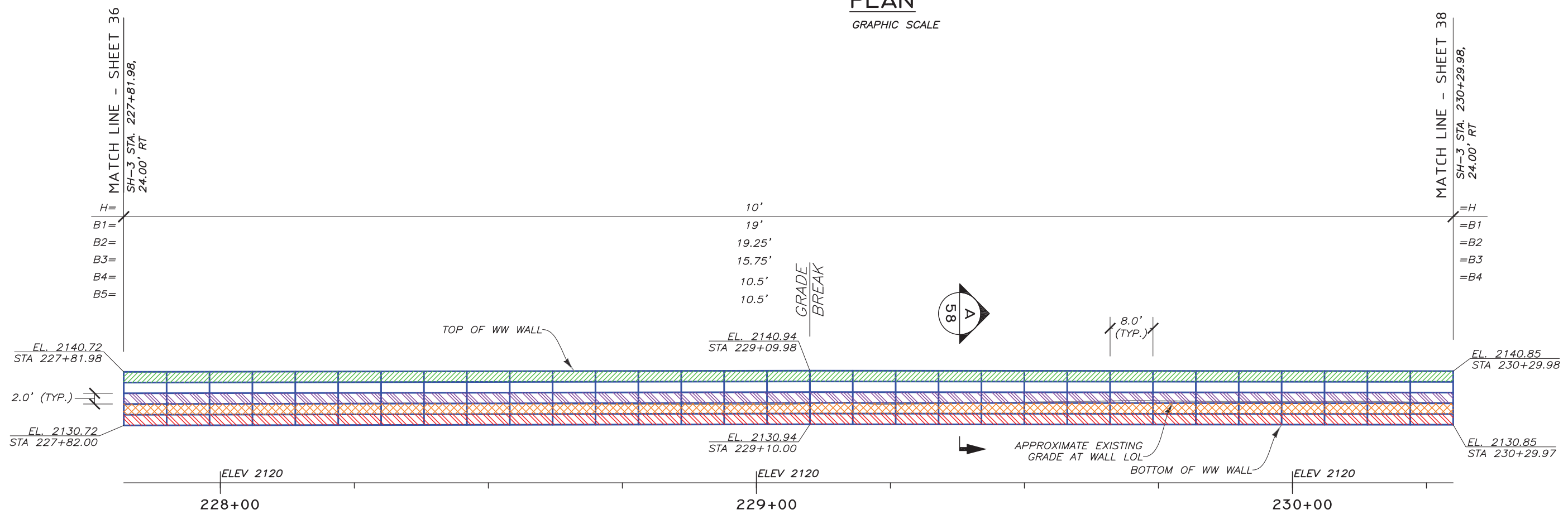

**DEVELOPED ELEVATION - (FRONT FACE)**  
GRAPHIC SCALE

**LEGEND**

	B1	8"x12", W7xW3.5-HDG	LOL	LAYOUT LINE
	B2	8"x21", W4.5xW4-HDG	H	WALL HEIGHT (BOTTOM MAT TO CAP MAT)
	B3	8"x21", W4.5xW4-HDG (W/GEOFOAM)	B	MAT LENGTH
	B4	8"x21", W4.5xW4-HDG (W/GEOFOAM)	WW	WELDED WIRE
	B5	8"x21", W4.5xW4-HDG		

03584-SH-3\_Goosehaven\_Rd\_I\_PREP\_2-4-2022.dwg  
2/4/2022 10:54 AM  
RVanLeuven

REV.	DATE	BY	DESCRIPTION	CADD:
0	12/30/2021	RGV	ISSUED FOR OWNER REVIEW	RGV
1	2/4/2022	RGV	ISSUED FOR OWNER REVIEW IN RESPONSE TO COMMENTS	RGV
				CHECKED: SGC

**HILFIKER RETAINING WALLS**

1902 Hilfiker Lane  
Eureka, CA 95503-5711  
TOLL-FREE 800.762.8962  
PH 707.443.5093 FAX 707.443.2891  
WEB SITE www.hilfiker.com E-MAIL info@hilfiker.com

**AMERICAN GEOTECHNICS**

American Geotechnics  
5260 Chinden Blvd.  
Boise, ID 83714  
(208) 658-8700  
Fax: (208) 658-8703

PLAN & ELEVATION	
WW WALL	
SH-3, GOOSEHAVEN RD. TO ROUND LAKE RD.	
ITD	BENEWAH COUNTY, ID

DWG DATE:	4 FEB 2022
HRW NO.:	210714AW
SHEET	37
OF	61

PROFESSIONAL ENGINEER  
2/4/2022  
15993  
AN G. VAN LEUVEN  
STATE OF IDAHO

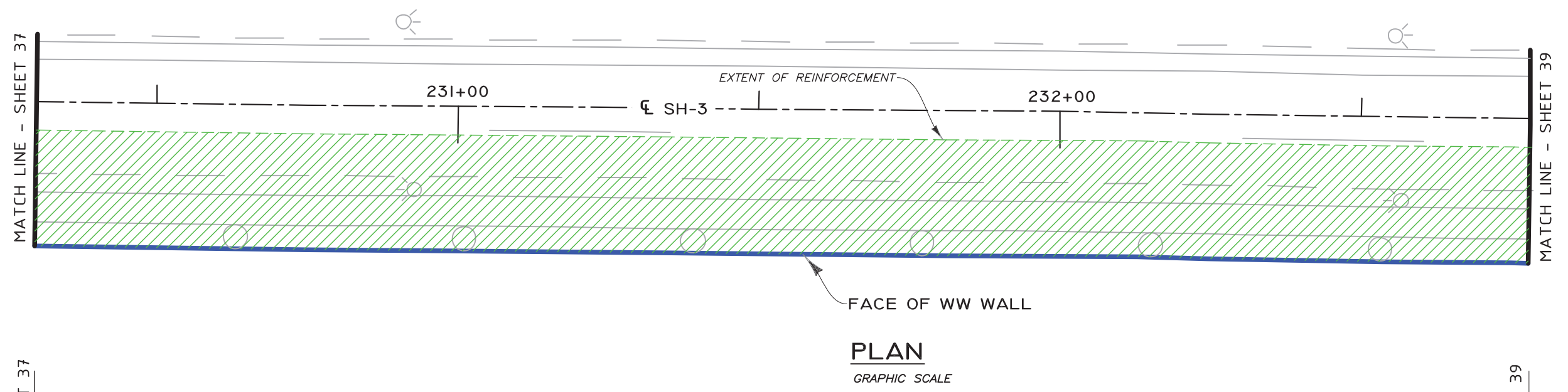
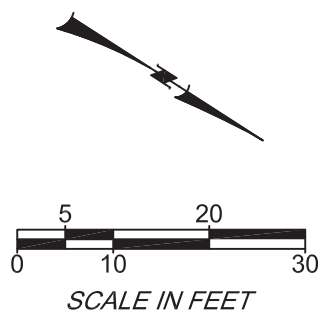

**PLAN**  
GRAPHIC SCALE

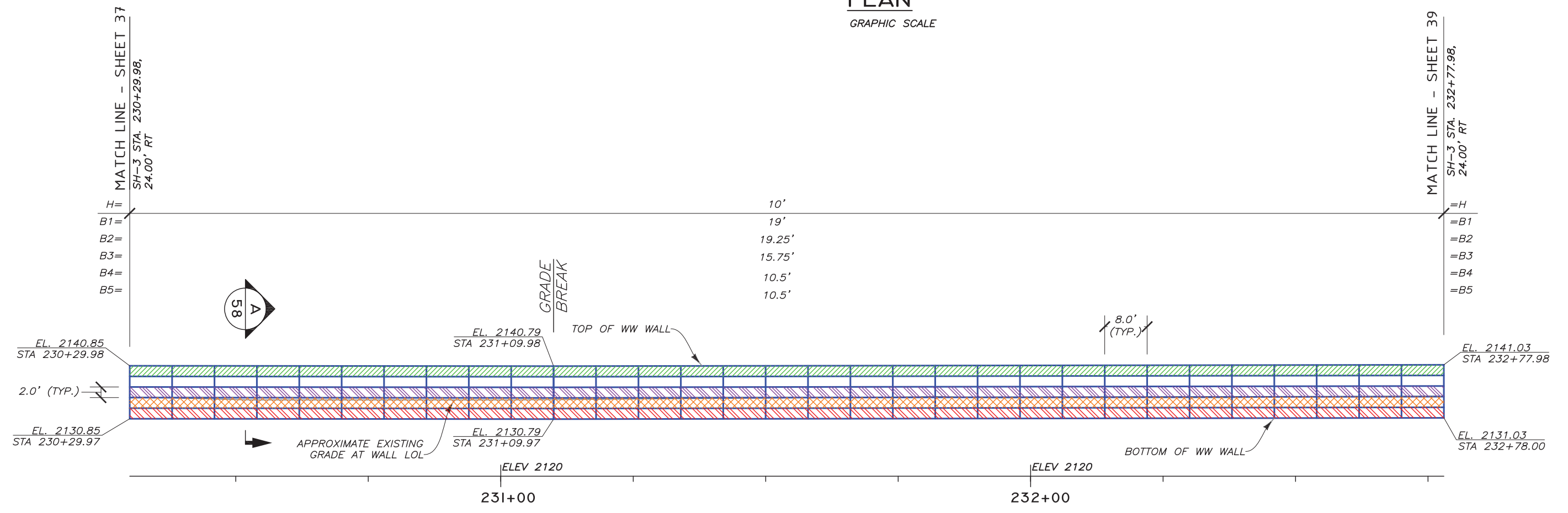

**DEVELOPED ELEVATION - (FRONT FACE)**  
GRAPHIC SCALE

**LEGEND**

	B1	8"X12", W7xW3.5-HDG	LOL	LAYOUT LINE
	B2	8"X21", W4.5xW4-HDG	H	WALL HEIGHT (BOTTOM MAT TO CAP MAT)
	B3	8"X21", W4.5xW4-HDG (W/GEOFOAM)	B	MAT LENGTH
	B4	8"X21", W4.5xW4-HDG (W/GEOFOAM)	WW	WELDED WIRE
	B5	8"X21", W4.5xW4-HDG		

03584-SH-3\_Goosehaven\_Rd\_I1\_PREP 2-4-2022.dwg  
2/4/2022 10:54 AM  
R:\ent\ent

REV.	DATE	BY	DESCRIPTION	CADD:
0	12/30/2021	RGV	ISSUED FOR OWNER REVIEW	RGV
1	2/4/2022	RGV	ISSUED FOR OWNER REVIEW IN RESPONSE TO COMMENTS	RGV
				SGC

**HILFIKER RETAINING WALLS**

1902 Hilfiker Lane  
Eureka, CA 95503-5711  
TOLL-FREE 800.762.8962  
PH 707.443.5093 FAX 707.443.2891  
WEB SITE www.hilfiker.com EMAIL info@hilfiker.com

**AMERICAN GEOTECHNICS**

American Geotechnics  
5260 Chinden Blvd.  
Boise, ID 83714  
(208) 658-8700  
Fax: (208) 658-8703

PLAN & ELEVATION	DWG DATE: 4 FEB 2022
WW WALL	HRW NO.:
SH-3, GOOSEHAVEN RD. TO ROUND LAKE RD.	210714AW
ITD	SHEET
BENEWAH COUNTY, ID	38
	OF 61

PROFESSIONAL ENGINEER  
2/4/2022  
15993  
STATE OF IDAHO  
G. VAN LEUVEN

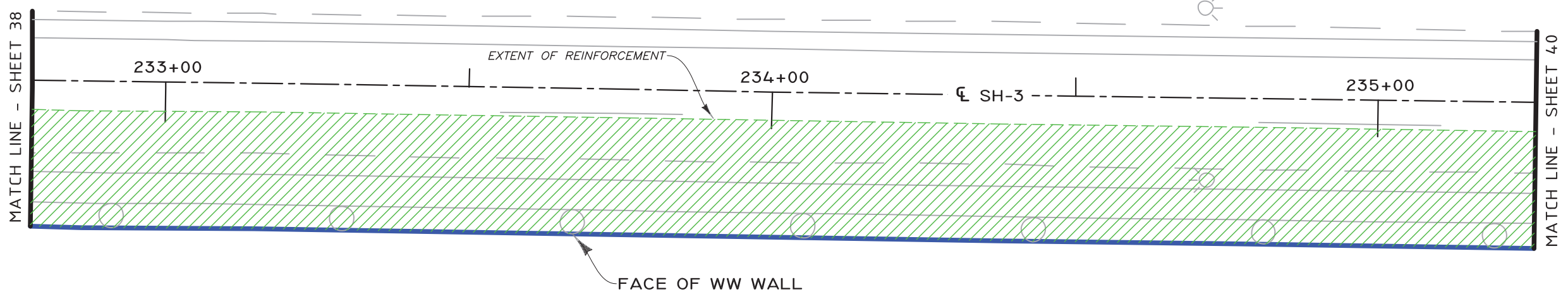
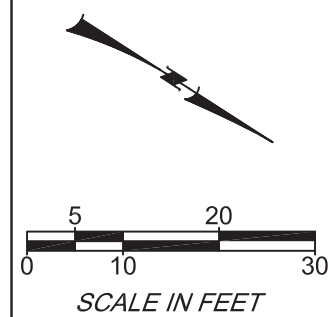

**PLAN**  
GRAPHIC SCALE

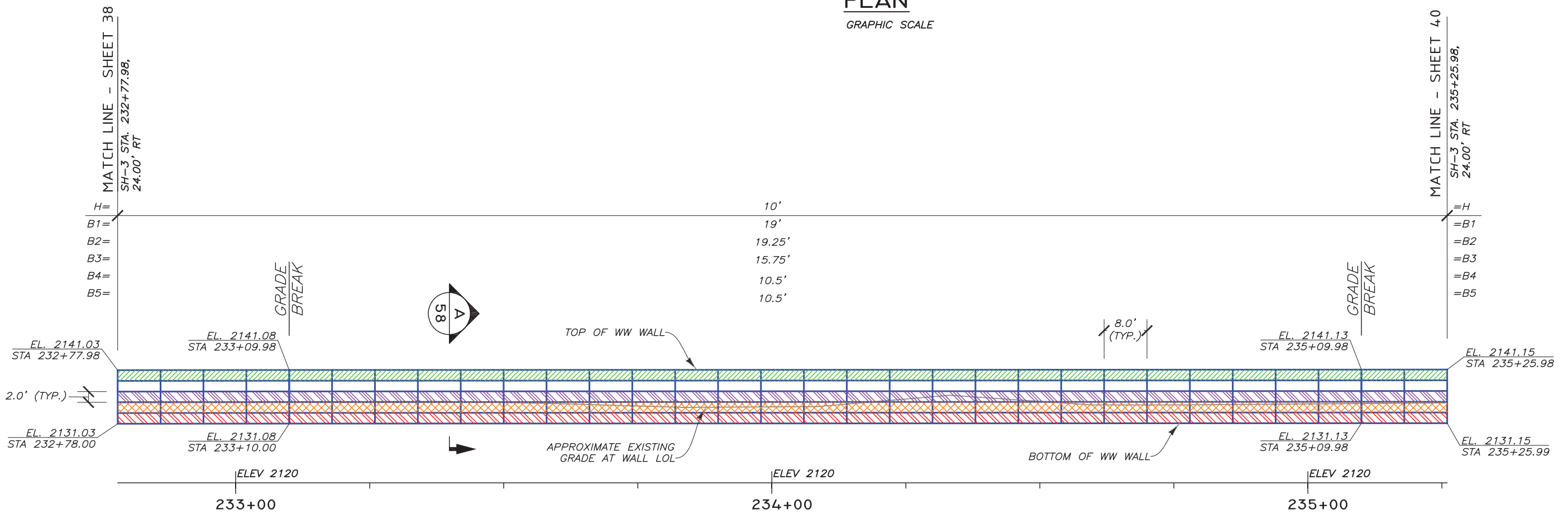

**DEVELOPED ELEVATION - (FRONT FACE)**  
GRAPHIC SCALE

**LEGEND**

	B1	8"x12", W7xW3.5-HDG	LOL	LAYOUT LINE
	B2	8"x21", W4.5xW4-HDG	H	WALL HEIGHT (BOTTOM MAT TO CAP MAT)
	B3	8"x21", W4.5xW4-HDG (W/GEOFOAM)	B	MAT LENGTH
	B4	8"x21", W4.5xW4-HDG (W/GEOFOAM)	WW	WELDED WIRE
	B5	8"x21", W4.5xW4-HDG		

REV.	DATE	BY	DESCRIPTION	CADD:
0	12/30/2021	RGV	ISSUED FOR OWNER REVIEW	RGV
1	2/4/2022	RGV	ISSUED FOR OWNER REVIEW IN RESPONSE TO COMMENTS	RGV
				CHECKED: SGC

**HILFIKER RETAINING WALLS**

1902 Hilfiker Lane  
Eureka, CA 95503-5711  
TOLL-FREE 800.752.8962  
PH 707.443.5093 FAX 707.443.2891  
WEB SITE www.hilfiker.com EMAIL info@hilfiker.com

**AMERICAN GEOTECHNICS**

American Geotechnics  
5260 Chinden Blvd.  
Boise, ID 83714  
(208) 658-8700  
Fax: (208) 658-8703

PLAN & ELEVATION  
WW WALL  
SH-3, GOOSEHAVEN RD.  
TO ROUND LAKE RD.  
ITD BENEWAH COUNTY, ID

DWG DATE: 4 FEB 2022
HRW NO.: 210714AW
SHEET 39 OF 61

PROFESSIONAL ENGINEER  
2/4/2022  
15993  
STATE OF IDAHO  
PIAN G. VAN LEUVEN

03584-SH-3\_Goosehaven\_Rd\_ID\_PREP 2-4-2022.dwg  
2/4/2022 10:54 AM  
RVanLeuven

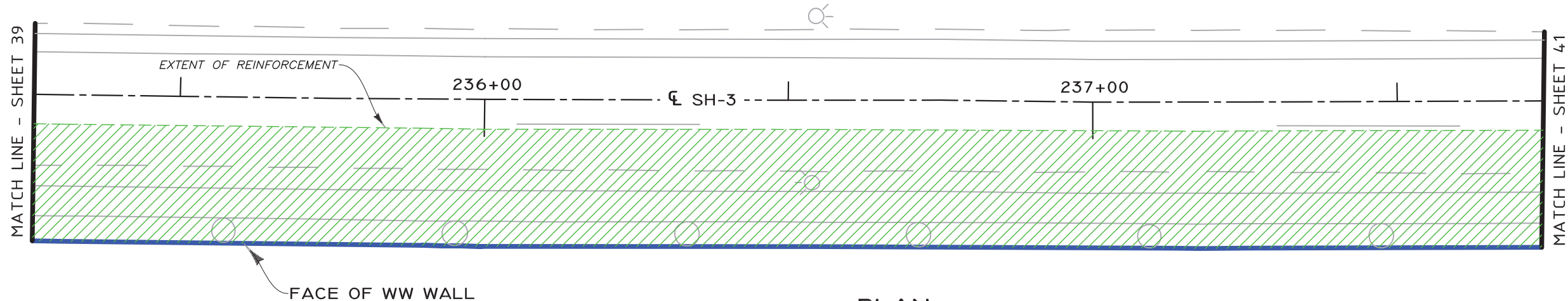
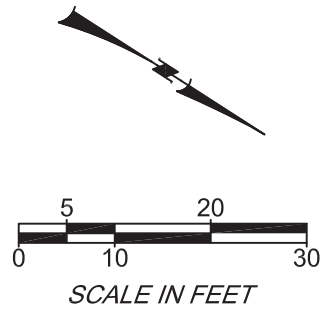

**PLAN**  
GRAPHIC SCALE

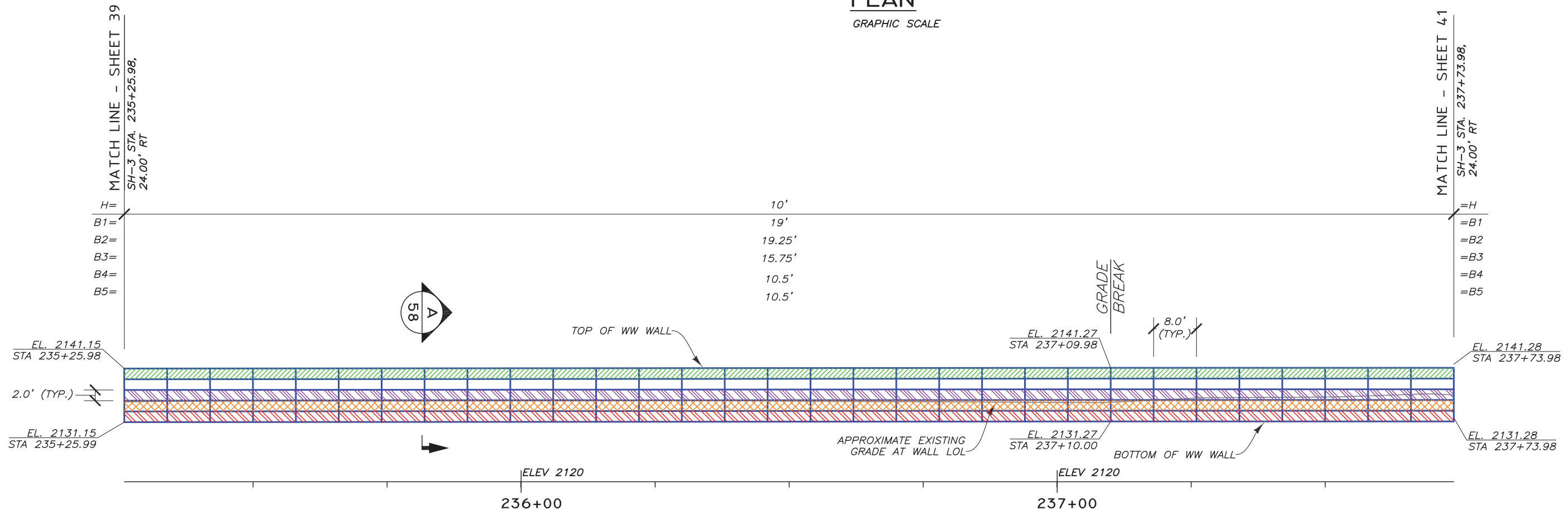

**DEVELOPED ELEVATION - (FRONT FACE)**  
GRAPHIC SCALE

**LEGEND**

	B1	8"x12", W7xW3.5-HDG	LOL	LAYOUT LINE
	B2	8"x21", W4.5xW4-HDG	H	WALL HEIGHT (BOTTOM MAT TO CAP MAT)
	B3	8"x21", W4.5xW4-HDG (W/GEOFOAM)	B	MAT LENGTH
	B4	8"x21", W4.5xW4-HDG (W/GEOFOAM)	WW	WELDED WIRE
	B5	8"x21", W4.5xW4-HDG		

03584\_S1-3\_Goosehaven\_Rd\_11\_PREP\_2-4-2022.dwg

2/4/2022 10:54 AM

REV.	DATE	BY	DESCRIPTION	CADD:
0	12/30/2021	RGV	ISSUED FOR OWNER REVIEW	RGV
1	2/4/2022	RGV	ISSUED FOR OWNER REVIEW IN RESPONSE TO COMMENTS	DESIGNED: RGV
				CHECKED: SGC

**HILFIKER RETAINING WALLS**

1902 Hilfiker Lane  
Eureka, CA 95503-5711  
TOLL-FREE 800.752.8962  
PH 707.443.5093 FAX 707.443.2891  
WEB SITE www.hilfiker.com E-MAIL info@hilfiker.com

**AMERICAN GEOTECHNICS**

American Geotechnics  
5260 Chinden Blvd.  
Boise, ID 83714  
(208) 658-8700  
Fax: (208) 658-8703

PLAN & ELEVATION  
WW WALL  
SH-3, GOOSEHAVEN RD.  
TO ROUND LAKE RD.  
ITD BENEWAH COUNTY, ID

DWG DATE:	4 FEB 2022
HRW NO.:	210714AW
SHEET	40
OF	61

PROFESSIONAL ENGINEER  
2/4/2022  
15993  
*[Signature]*  
STATE OF IDAHO  
JAN G. VAN LEUVEN



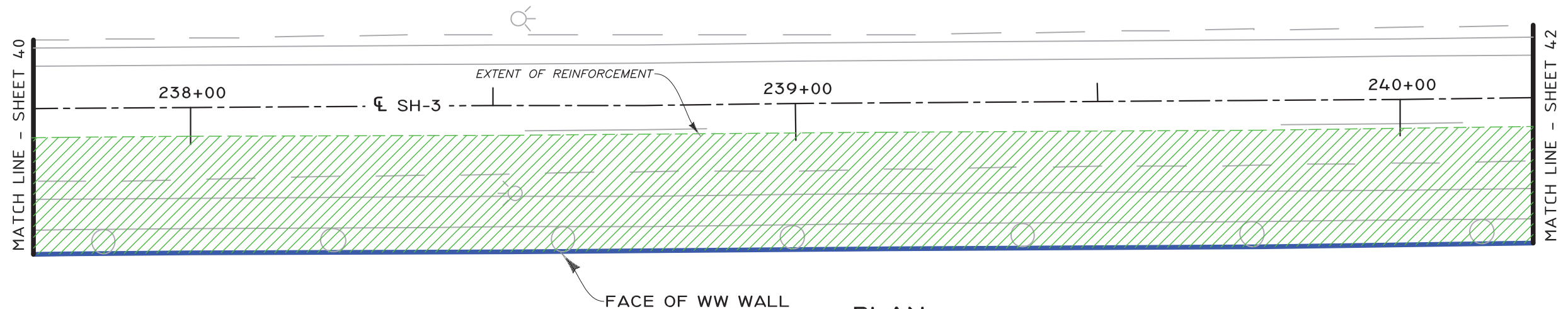
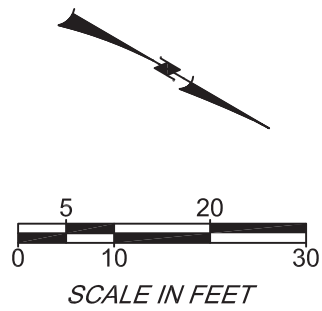

**PLAN**  
GRAPHIC SCALE

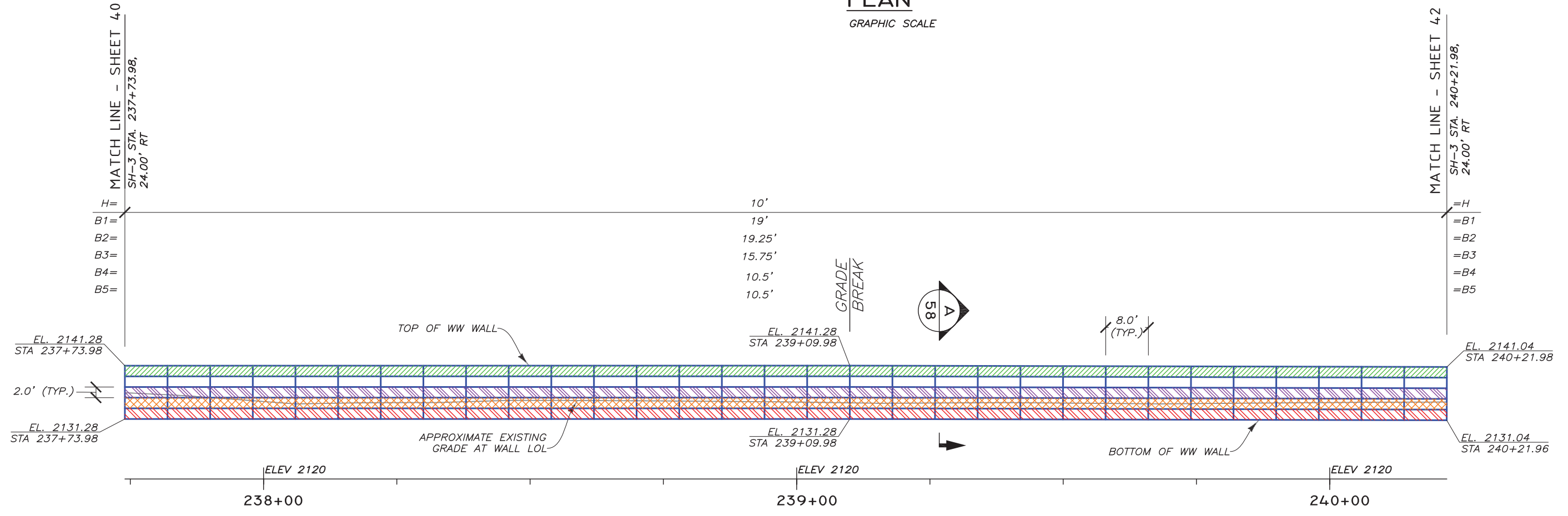

**DEVELOPED ELEVATION - (FRONT FACE)**  
GRAPHIC SCALE

**LEGEND**

	B1	8"x12", W7xW3.5-HDG	LOL	LAYOUT LINE
	B2	8"x21", W4.5xW4-HDG	H	WALL HEIGHT (BOTTOM MAT TO CAP MAT)
	B3	8"x21", W4.5xW4-HDG (W/GEOFOAM)	B	MAT LENGTH
	B4	8"x21", W4.5xW4-HDG (W/GEOFOAM)	WW	WELDED WIRE
	B5	8"x21", W4.5xW4-HDG		

THE DESIGN CONTAINED ON THESE DRAWINGS IS BASED ON INFORMATION PROVIDED BY THE OWNER. ON THE BASIS OF THIS INFORMATION, THE HILFIKER COMPANY HAS DESIGNED, AND IS RESPONSIBLE FOR THE INTERNAL STABILITY OF THE STRUCTURE ONLY. EXTERNAL STABILITY, INCLUDING FOUNDATION AND SLOPE STABILITY, IS THE RESPONSIBILITY OF THE OWNER.

REV.	DATE	BY	DESCRIPTION
0	12/30/2021	RGV	ISSUED FOR OWNER REVIEW
1	2/4/2022	RGV	ISSUED FOR OWNER REVIEW IN RESPONSE TO COMMENTS

CADD:	RGV
DESIGNED:	RGV
CHECKED:	SGC

**HILFIKER RETAINING WALLS**

1902 HilfiKER Lane  
Eureka, CA 95503-5711  
TOLL-FREE 800.752.8962  
PH 707.443.5093 FAX 707.443.2891  
WEB SITE www.hilfiKER.com E-MAIL info@hilfiKER.com

**AMERICAN GEOTECHNICS**

American Geotechnics  
5260 Chinden Blvd.  
Boise, ID 83714  
(208) 658-8700  
Fax: (208) 658-8703

PLAN & ELEVATION	
WW WALL	
SH-3, GOOSEHAVEN RD. TO ROUND LAKE RD.	
ITD	BENEWAH COUNTY, ID

DWG DATE:	4 FEB 2022
HRW NO.:	210714AW
SHEET	41
OF	61

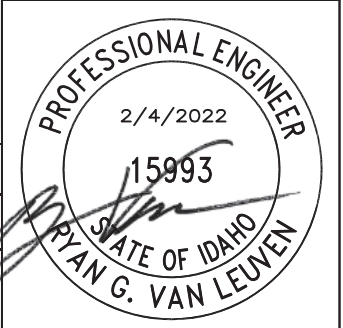

03584-SH-3\_Goosehaven\_Rd\_ID\_PREP\_2-4-2022.dwg

R:\VanLeuven

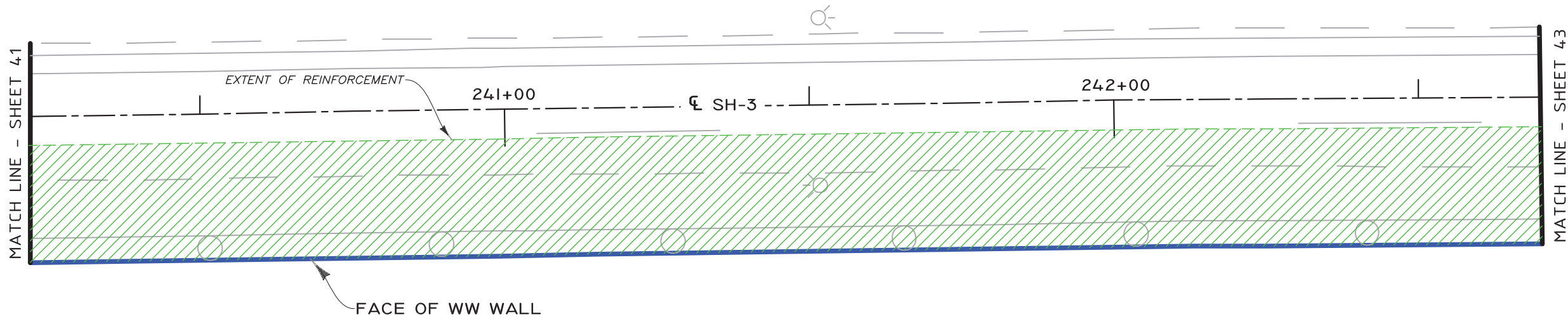
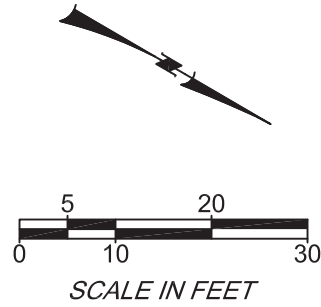

**PLAN**  
GRAPHIC SCALE

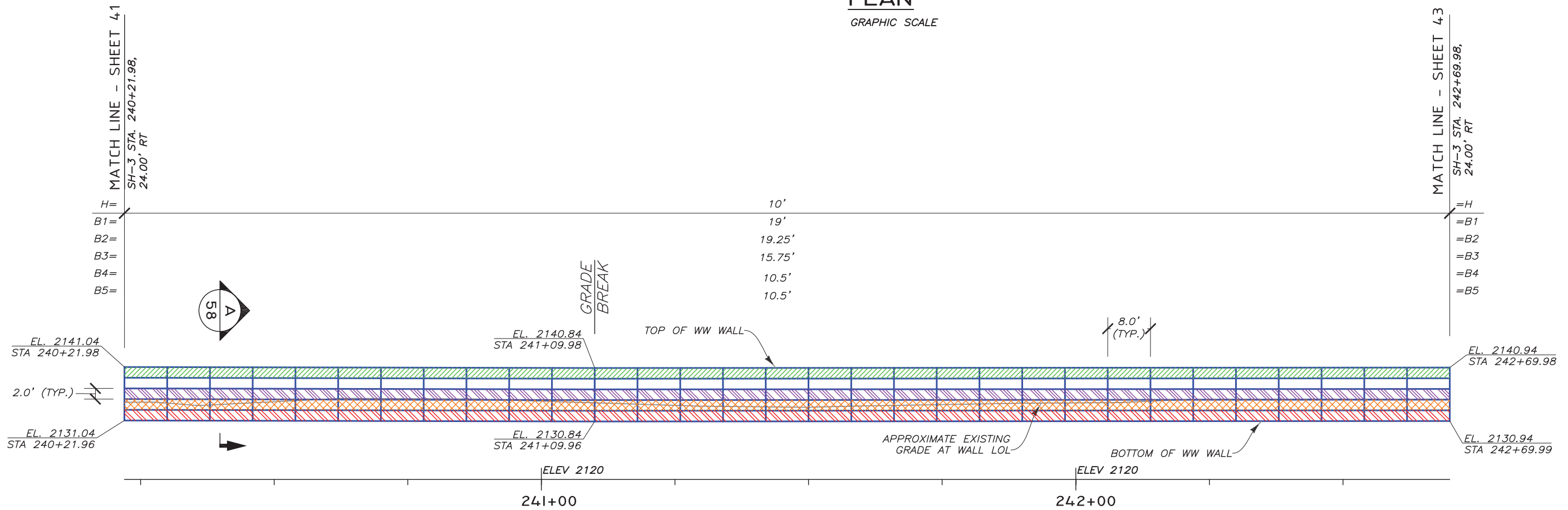

**DEVELOPED ELEVATION - (FRONT FACE)**

GRAPHIC SCALE

**LEGEND**

	B1	8"x12", W7xW3.5-HDG	LOL	LAYOUT LINE
	B2	8"x21", W4.5xW4-HDG	H	WALL HEIGHT (BOTTOM MAT TO CAP MAT)
	B3	8"x21", W4.5xW4-HDG (W/GEOFOAM)	B	MAT LENGTH
	B4	8"x21", W4.5xW4-HDG (W/GEOFOAM)	WW	WELDED WIRE
	B5	8"x21", W4.5xW4-HDG		

03584-SH-3\_Goosehaven\_Rd\_I1\_PREP 2-4-2022.dwg  
2/4/2022 10:54 AM  
RVanLeuven

REV.	DATE	BY	DESCRIPTION	CADD:
0	12/30/2021	RGV	ISSUED FOR OWNER REVIEW	RGV
1	2/4/2022	RGV	ISSUED FOR OWNER REVIEW IN RESPONSE TO COMMENTS	DESIGNED: RGV CHECKED: SGC

**HILFIKER RETAINING WALLS**

1902 Hilfiker Lane  
Eureka, CA 95503-5711  
TOLL-FREE 800.752.8962  
PH 707.443.5093 FAX 707.443.2891  
WEB SITE www.hilfiker.com E-MAIL info@hilfiker.com

**AMERICAN GEOTECHNICS**

American Geotechnics  
5260 Chinden Blvd.  
Boise, ID 83714  
(208) 658-8700  
Fax: (208) 658-8703

PLAN & ELEVATION  
WW WALL  
SH-3, GOOSEHAVEN RD.  
TO ROUND LAKE RD.  
ITD BENEWAH COUNTY, ID

DWG DATE:	4 FEB 2022
HRW NO.:	210714AW
SHEET	42
OF	61

PROFESSIONAL ENGINEER  
2/4/2022  
15993  
G. VAN LEUVEN

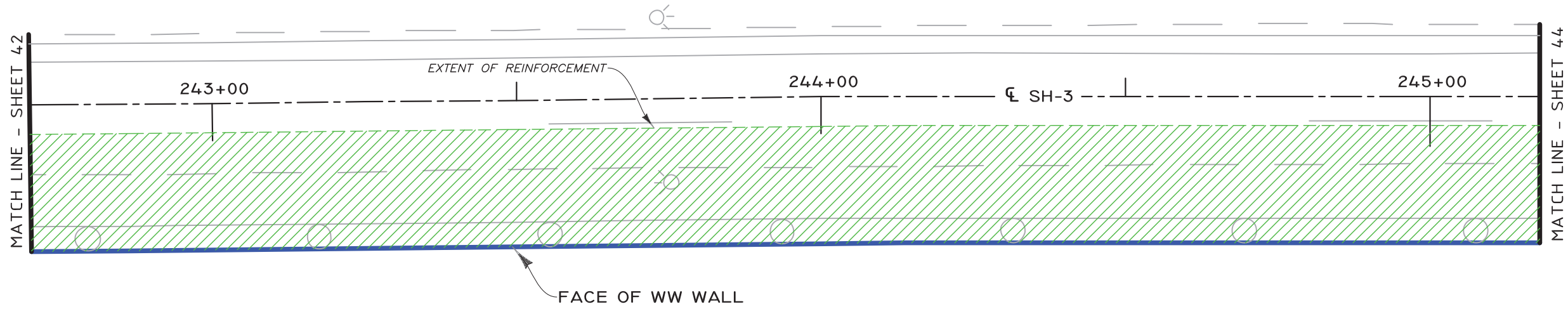
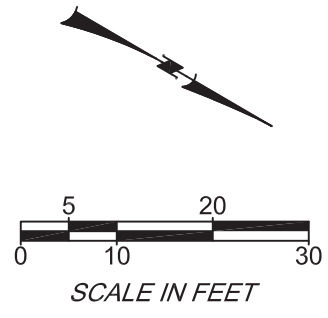

**PLAN**  
GRAPHIC SCALE

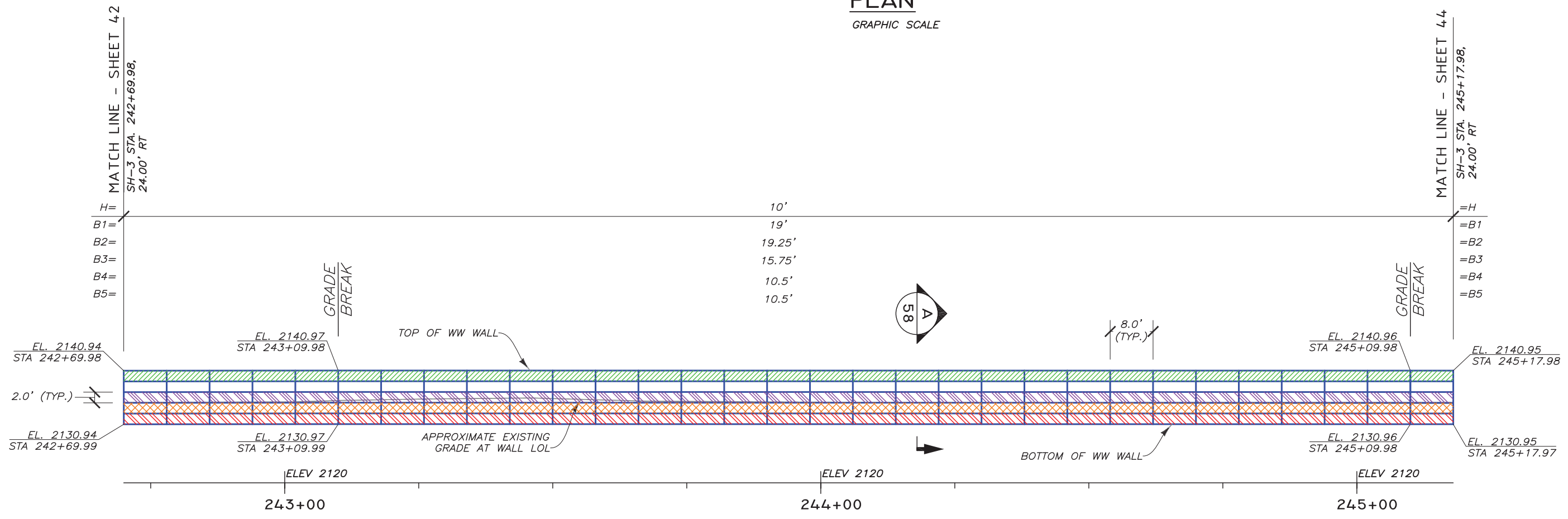

**DEVELOPED ELEVATION - (FRONT FACE)**  
GRAPHIC SCALE

**LEGEND**

	B1	8"x12", W7xW3.5-HDG	LOL	LAYOUT LINE
	B2	8"x21", W4.5xW4-HDG	H	WALL HEIGHT (BOTTOM MAT TO CAP MAT)
	B3	8"x21", W4.5xW4-HDG (W/GEOFOAM)	B	MAT LENGTH
	B4	8"x21", W4.5xW4-HDG (W/GEOFOAM)	WW	WELDED WIRE
	B5	8"x21", W4.5xW4-HDG		

03584-SH-3\_Goosehaven\_Rd\_I\_PREP 2-4-2022.dwg

2/4/2022 10:54 AM

REV.	DATE	BY	DESCRIPTION	CADD:
0	12/30/2021	RGV	ISSUED FOR OWNER REVIEW	RGV
1	2/4/2022	RGV	ISSUED FOR OWNER REVIEW IN RESPONSE TO COMMENTS	RGV
				CHECKED: SGC

**HILFIKER RETAINING WALLS**

1902 Hilfiker Lane  
Eureka, CA 95503-5711  
TOLL-FREE 800.762.8962  
PH 707.443.5093 FAX 707.443.2891  
WEB SITE www.hilfiker.com E-MAIL info@hilfiker.com

**AMERICAN GEOTECHNICS**

American Geotechnics  
5260 Chinden Blvd.  
Boise, ID 83714  
(208) 658-8700  
Fax: (208) 658-8703

PLAN & ELEVATION	DWG DATE: 4 FEB 2022
WW WALL	HRW NO.: 210714AW
SH-3, GOOSEHAVEN RD. TO ROUND LAKE RD.	SHEET 43 OF 61
ITD BENEWAH COUNTY, ID	

PROFESSIONAL ENGINEER  
2/4/2022  
15993  
AN G. VAN LEUVEN

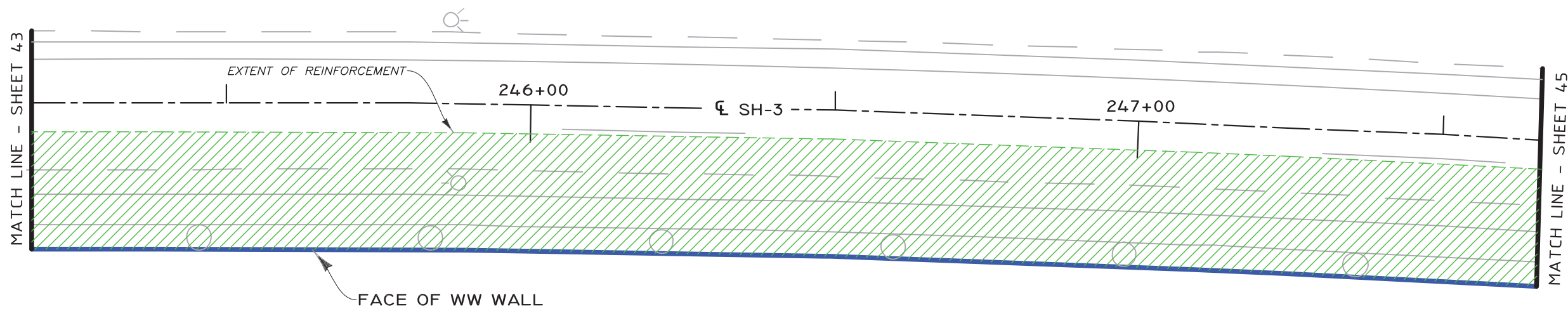
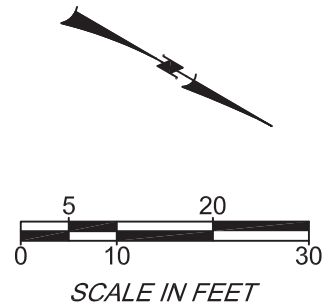

**PLAN**  
GRAPHIC SCALE

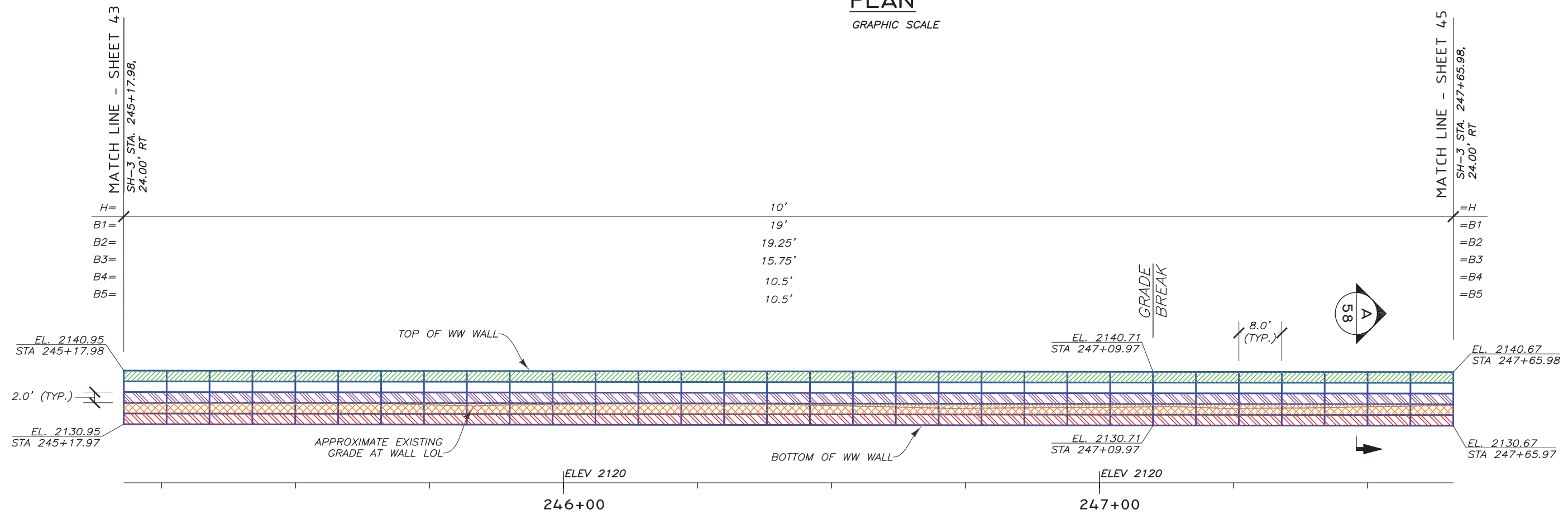

**DEVELOPED ELEVATION - (FRONT FACE)**  
GRAPHIC SCALE

**LEGEND**

	B1	8"x12", W7xW3.5-HDG	LOL	LAYOUT LINE
	B2	8"x21", W4.5xW4-HDG	H	WALL HEIGHT (BOTTOM MAT TO CAP MAT)
	B3	8"x21", W4.5xW4-HDG (W/GEOFOAM)	B	MAT LENGTH
	B4	8"x21", W4.5xW4-HDG (W/GEOFOAM)	WW	WELDED WIRE
	B5	8"x21", W4.5xW4-HDG		

REV.	DATE	BY	DESCRIPTION	CADD:
0	12/30/2021	RGV	ISSUED FOR OWNER REVIEW	RGV
1	2/4/2022	RGV	ISSUED FOR OWNER REVIEW IN RESPONSE TO COMMENTS	RGV
				CHECKED: SGC

**HILFIKER RETAINING WALLS**

1902 Hilfiker Lane  
Eureka, CA 95503-5711  
TOLL-FREE 800.752.8962  
PH 707.443.5093 FAX 707.443.2891  
WEB SITE www.hilfiker.com E-MAIL info@hilfiker.com

**AMERICAN GEOTECHNICS**

American Geotechnics  
5260 Chinden Blvd.  
Boise, ID 83714  
(208) 658-8700  
Fax: (208) 658-8703

PLAN & ELEVATION  
WW WALL  
SH-3, GOOSEHAVEN RD.  
TO ROUND LAKE RD.  
ITD BENEWAH COUNTY, ID

DWG DATE:	4 FEB 2022
HRW NO.:	210714AW
SHEET	44
OF	61

PROFESSIONAL ENGINEER  
2/4/2022  
15993  
STATE OF IDAHO  
JAN G. VAN LEUVEN

03584-SH-3\_Goosehaven\_Rd\_ID\_PREP\_2-4-2022.dwg  
2/4/2022 10:54 AM  
RVanLeuven

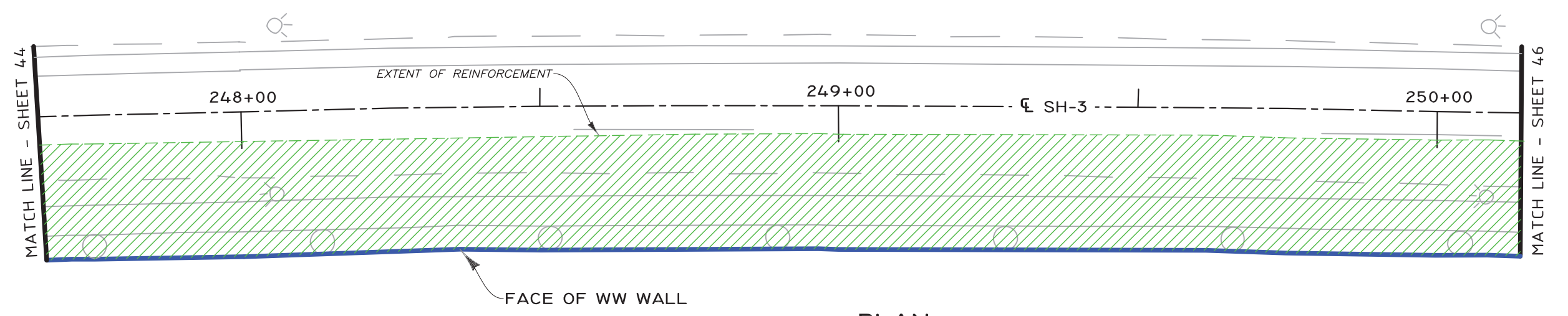
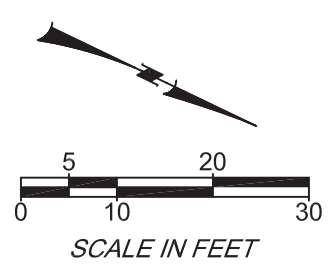

**PLAN**  
GRAPHIC SCALE

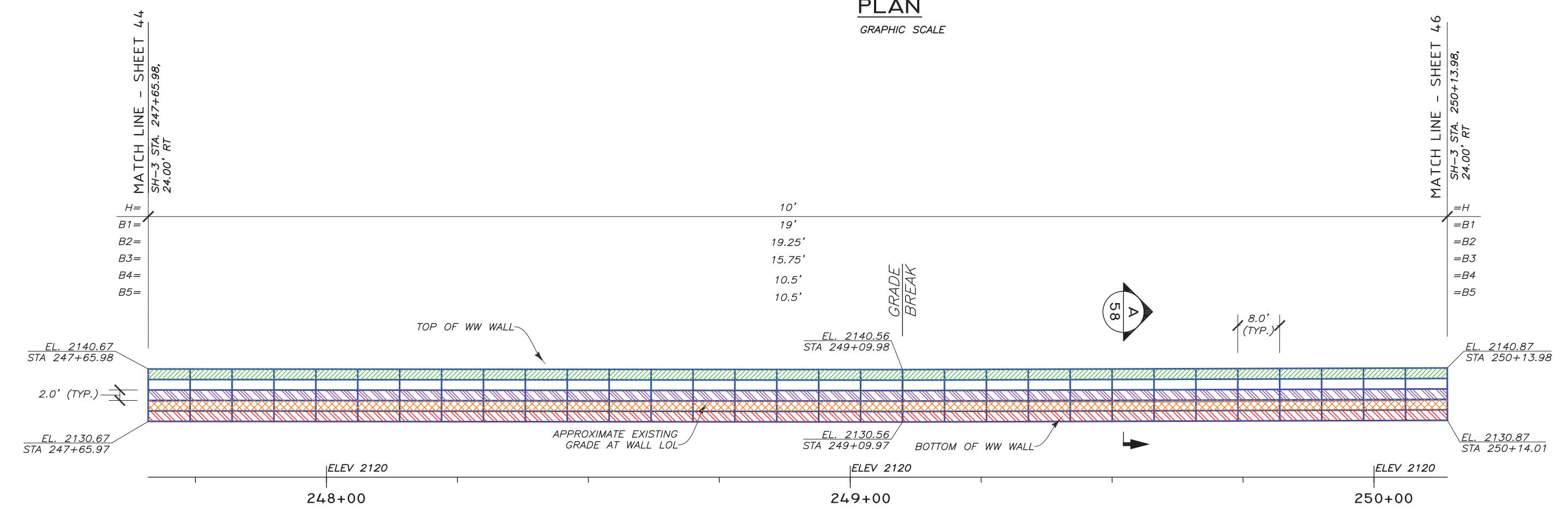

**DEVELOPED ELEVATION - (FRONT FACE)**  
GRAPHIC SCALE

**LEGEND**

	B1	8"x12", W7xW3.5-HDG	LOL	LAYOUT LINE
	B2	8"x21", W4.5xW4-HDG	H	WALL HEIGHT (BOTTOM MAT TO CAP MAT)
	B3	8"x21", W4.5xW4-HDG (W/GEOFOAM)	B	MAT LENGTH
	B4	8"x21", W4.5xW4-HDG (W/GEOFOAM)	WW	WELDED WIRE
	B5	8"x21", W4.5xW4-HDG		

03584-SH-3\_Goosehaven\_Rd\_ID PREP 2-4-2022.dwg  
2/4/2022 10:54 AM  
RVanLeuven

REV.	DATE	BY	DESCRIPTION	CADD:
0	12/30/2021	RGV	ISSUED FOR OWNER REVIEW	RGV
1	2/4/2022	RGV	ISSUED FOR OWNER REVIEW IN RESPONSE TO COMMENTS	RGV
				CHECKED: SGC

**HILFIKER RETAINING WALLS**

1902 Hilfiker Lane  
Eureka, CA 95503-5711  
TOLL-FREE 800.752.8962  
PH 707.443.5093 FAX 707.443.2891  
WEB SITE www.hilfiker.com E-MAIL info@hilfiker.com

**AMERICAN GEOTECHNICS**

American Geotechnics  
5260 Chinden Blvd.  
Boise, ID 83714  
(208) 658-8700  
Fax: (208) 658-8703

PLAN & ELEVATION		DWG DATE: 4 FEB 2022
WW WALL		HRW NO.:
SH-3, GOOSEHAVEN RD. TO ROUND LAKE RD.		210714AW
ITD	BENEWAH COUNTY, ID	SHEET 45 OF 61

PROFESSIONAL ENGINEER

2/4/2022

15993

RYAN G. VAN LEUVEN

STATE OF IDAHO

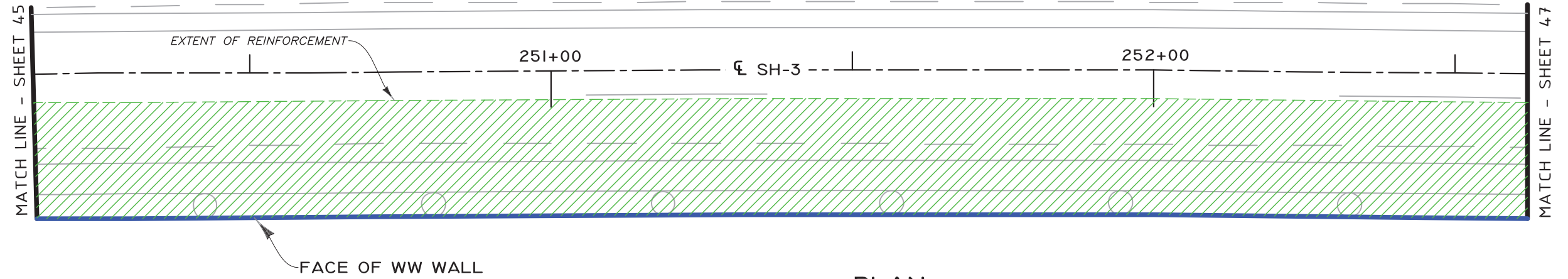
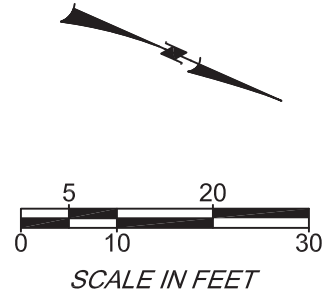

**PLAN**  
GRAPHIC SCALE

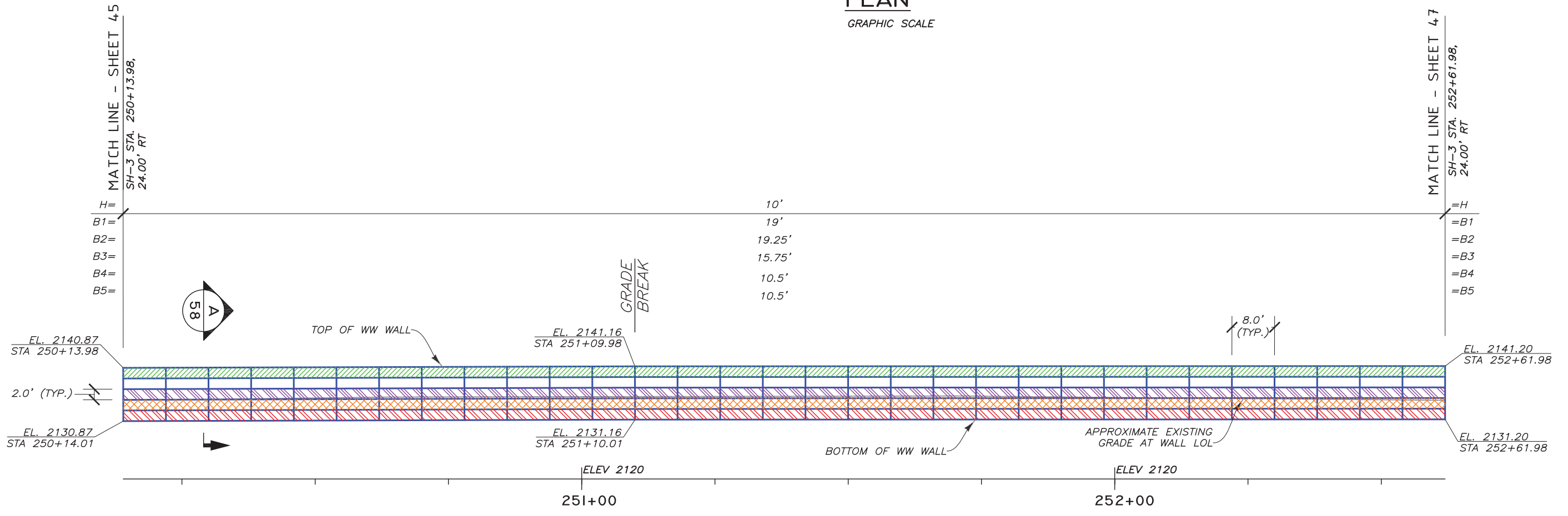

**DEVELOPED ELEVATION - (FRONT FACE)**  
GRAPHIC SCALE

**LEGEND**

	B1	8"x12", W7xW3.5-HDG	LOL	LAYOUT LINE
	B2	8"x21", W4.5xW4-HDG	H	WALL HEIGHT (BOTTOM MAT TO CAP MAT)
	B3	8"x21", W4.5xW4-HDG (W/GEOFOAM)	B	MAT LENGTH
	B4	8"x21", W4.5xW4-HDG (W/GEOFOAM)	WW	WELDED WIRE
	B5	8"x21", W4.5xW4-HDG		

03584-SH-3\_Goosehaven\_Rd\_I1\_PREP 2-4-2022.dwg  
2/4/2022 10:54 AM  
RVanLeuven

THE DESIGN CONTAINED ON THESE DRAWINGS IS BASED ON INFORMATION PROVIDED BY THE OWNER. ON THE BASIS OF THIS INFORMATION, THE HILFIKER COMPANY HAS DESIGNED, AND IS RESPONSIBLE FOR THE INTERNAL STABILITY OF THE STRUCTURE ONLY. EXTERNAL STABILITY, INCLUDING FOUNDATION AND SLOPE STABILITY, IS THE RESPONSIBILITY OF THE OWNER.

REV.	DATE	BY	DESCRIPTION	CADD:
0	12/30/2021	RGV	ISSUED FOR OWNER REVIEW	RGV
1	2/4/2022	RGV	ISSUED FOR OWNER REVIEW IN RESPONSE TO COMMENTS	DESIGNED: RGV
				CHECKED: SGC

**HILFIKER RETAINING WALLS**

1902 HilfiKER Lane  
Eureka, CA 95503-5711  
TOLL-FREE 800.752.8962  
PH 707.443.5093 FAX 707.443.2891  
WEB SITE www.hilfiKER.com EMAIL info@hilfiKER.com

**AMERICAN GEOTECHNICS**

American Geotechnics  
5260 Chinden Blvd.  
Boise, ID 83714  
(208) 658-8700  
Fax: (208) 658-8703

PLAN & ELEVATION  
WW WALL  
SH-3, GOOSEHAVEN RD.  
TO ROUND LAKE RD.  
ITD BENEWAH COUNTY, ID

DWG DATE:	4 FEB 2022
HRW NO.:	210714AW
SHEET	46
OF	61

PROFESSIONAL ENGINEER  
2/4/2022  
15993  
STATE OF IDAHO  
AN G. VAN LEUVEN

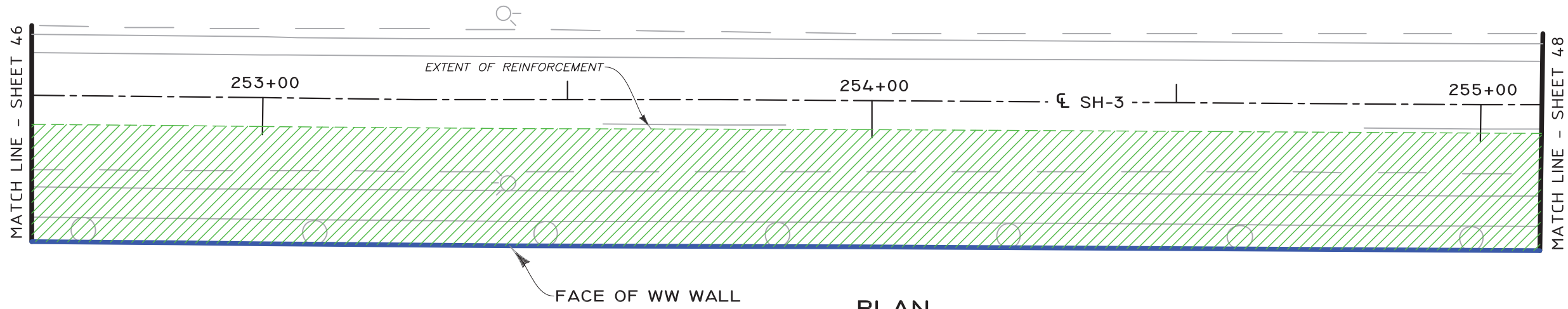
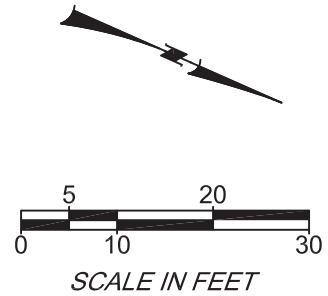

**PLAN**  
GRAPHIC SCALE

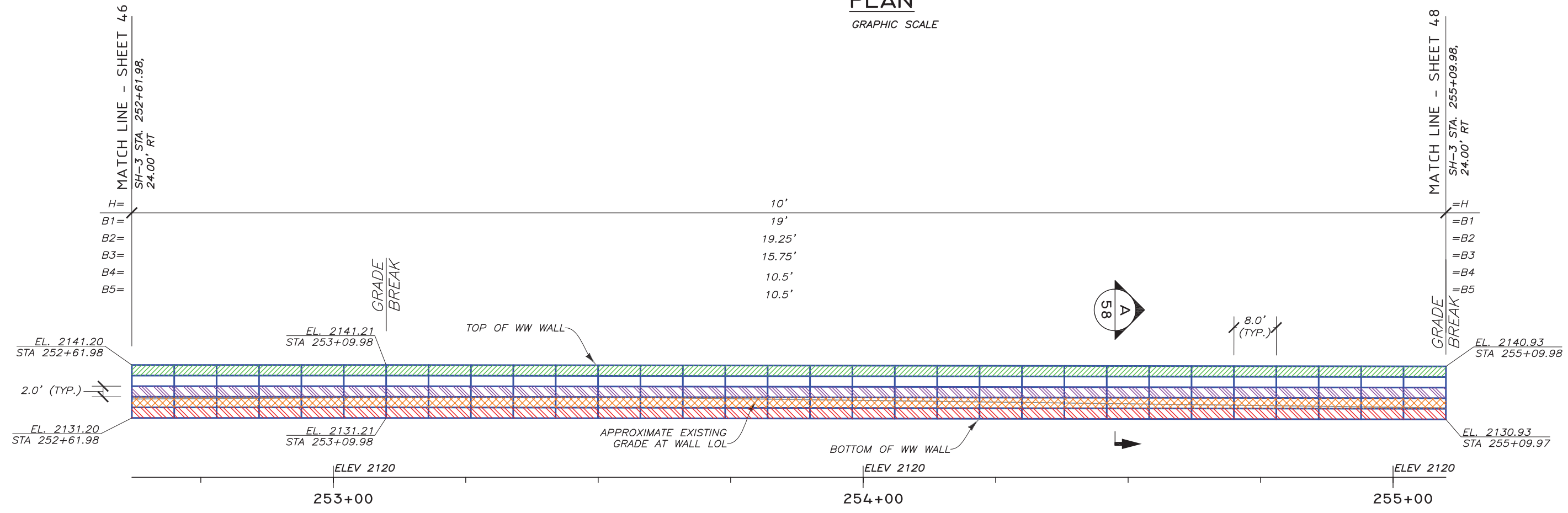

**DEVELOPED ELEVATION - (FRONT FACE)**  
GRAPHIC SCALE

**LEGEND**

	B1	8"x12", W7xW3.5-HDG	LOL	LAYOUT LINE
	B2	8"x21", W4.5xW4-HDG	H	WALL HEIGHT (BOTTOM MAT TO CAP MAT)
	B3	8"x21", W4.5xW4-HDG (W/GEOFOAM)	B	MAT LENGTH
	B4	8"x21", W4.5xW4-HDG (W/GEOFOAM)	WW	WELDED WIRE
	B5	8"x21", W4.5xW4-HDG		

03584-SH-3, Goosehaven Rd., PREP 2-4-2022.dwg  
2/4/2022 10:54 AM  
RVL/Leuven

REV.	DATE	BY	DESCRIPTION	CADD:
0	12/30/2021	RGV	ISSUED FOR OWNER REVIEW	RGV
1	2/4/2022	RGV	ISSUED FOR OWNER REVIEW IN RESPONSE TO COMMENTS	DESIGNED: RGV CHECKED: SGC

**HILFIKER RETAINING WALLS**

1902 HilfiKER Lane  
Eureka, CA 95503-5711  
TOLL-FREE 800.752.8962  
PH 707.443.5093 FAX 707.443.2891  
WEB SITE www.hilfiKER.com EMAIL info@hilfiKER.com

**AMERICAN GEOTECHNICS**

American Geotechnics  
5260 Chinden Blvd.  
Boise, ID 83714  
(208) 658-8700  
Fax: (208) 658-8703

PLAN & ELEVATION	DWG DATE: 4 FEB 2022
WW WALL	HRW NO.: 210714AW
SH-3, GOOSEHAVEN RD. TO ROUND LAKE RD.	SHEET 47
ITD BENEWAH COUNTY, ID	OF 61

PROFESSIONAL ENGINEER

2/4/2022

15993

AN G. VAN LEUVEN

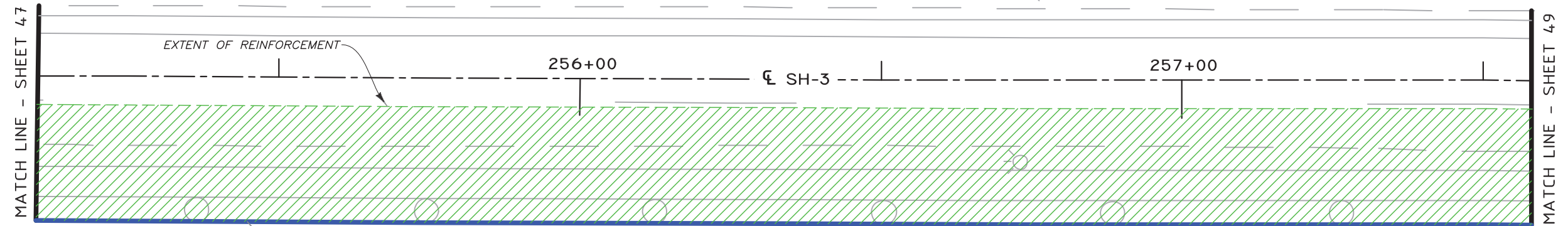
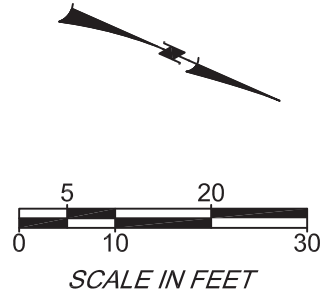

**PLAN**  
GRAPHIC SCALE

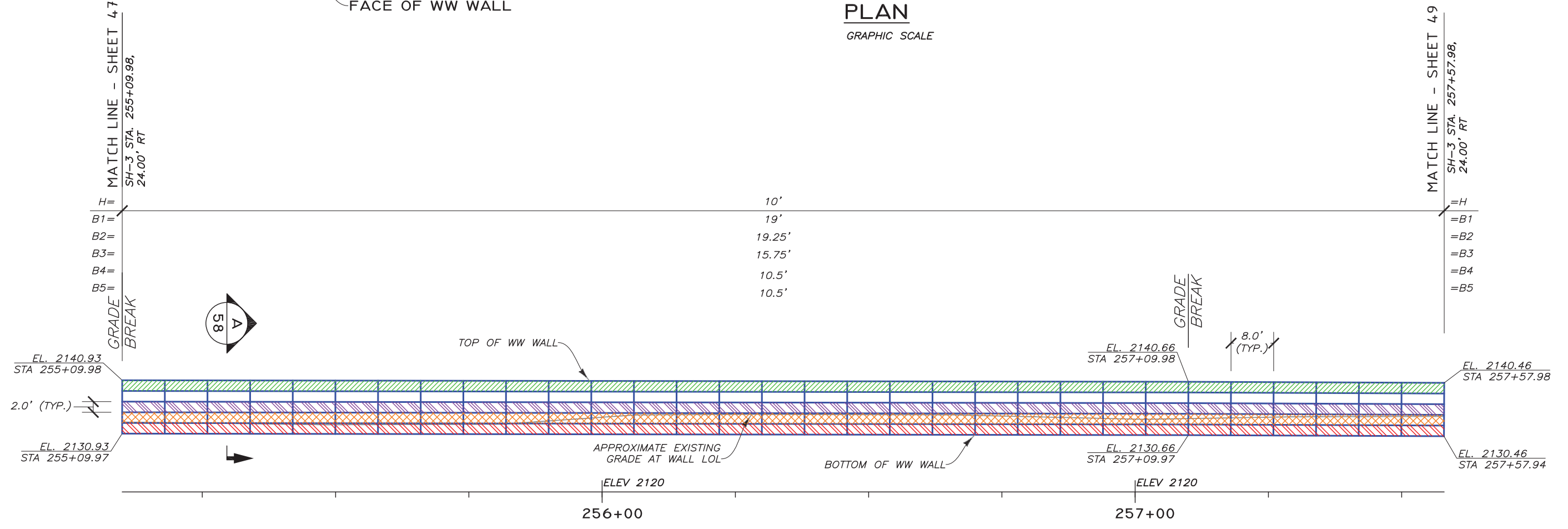

**DEVELOPED ELEVATION - (FRONT FACE)**  
GRAPHIC SCALE

**LEGEND**

	B1	8"x12", W7xW3.5-HDG	LOL	LAYOUT LINE
	B2	8"x21", W4.5xW4-HDG	H	WALL HEIGHT (BOTTOM MAT TO CAP MAT)
	B3	8"x21", W4.5xW4-HDG (W/GEOFOAM)	B	MAT LENGTH
	B4	8"x21", W4.5xW4-HDG (W/GEOFOAM)	WW	WELDED WIRE
	B5	8"x21", W4.5xW4-HDG		

03584-SH-3\_Goosehaven\_Rd\_ID\_PREP 2-4-2022.dwg

2/4/2022 10:54 AM

REV.	DATE	BY	DESCRIPTION	CADD:
0	12/30/2021	RGV	ISSUED FOR OWNER REVIEW	RGV
1	2/4/2022	RGV	ISSUED FOR OWNER REVIEW IN RESPONSE TO COMMENTS	DESIGNED: RGV CHECKED: SGC

**HILFIKER RETAINING WALLS**

1902 Hilfiker Lane  
Eureka, CA 95503-5711  
TOLL-FREE 800.752.8962  
PH 707.443.5093 FAX 707.443.2891  
WEB SITE www.hilfiker.com E-MAIL info@hilfiker.com

**AMERICAN GEOTECHNICS**

American Geotechnics  
5260 Chinden Blvd.  
Boise, ID 83714  
(208) 658-8700  
Fax: (208) 658-8703

PLAN & ELEVATION	DWG DATE: 4 FEB 2022
WW WALL	HRW NO.:
SH-3, GOOSEHAVEN RD. TO ROUND LAKE RD.	210714AW
ITD	SHEET
BENEWAH COUNTY, ID	48
	OF 61

PROFESSIONAL ENGINEER

2/4/2022

15993

STATE OF IDAHO

BRIGAN G. VAN LEUVEN



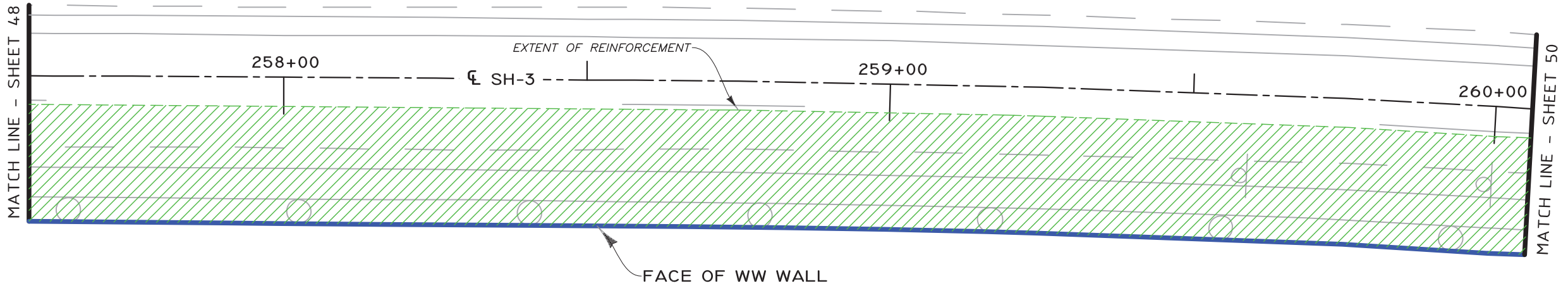
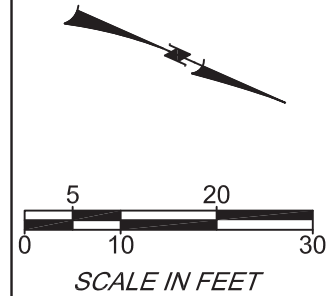

**PLAN**  
GRAPHIC SCALE

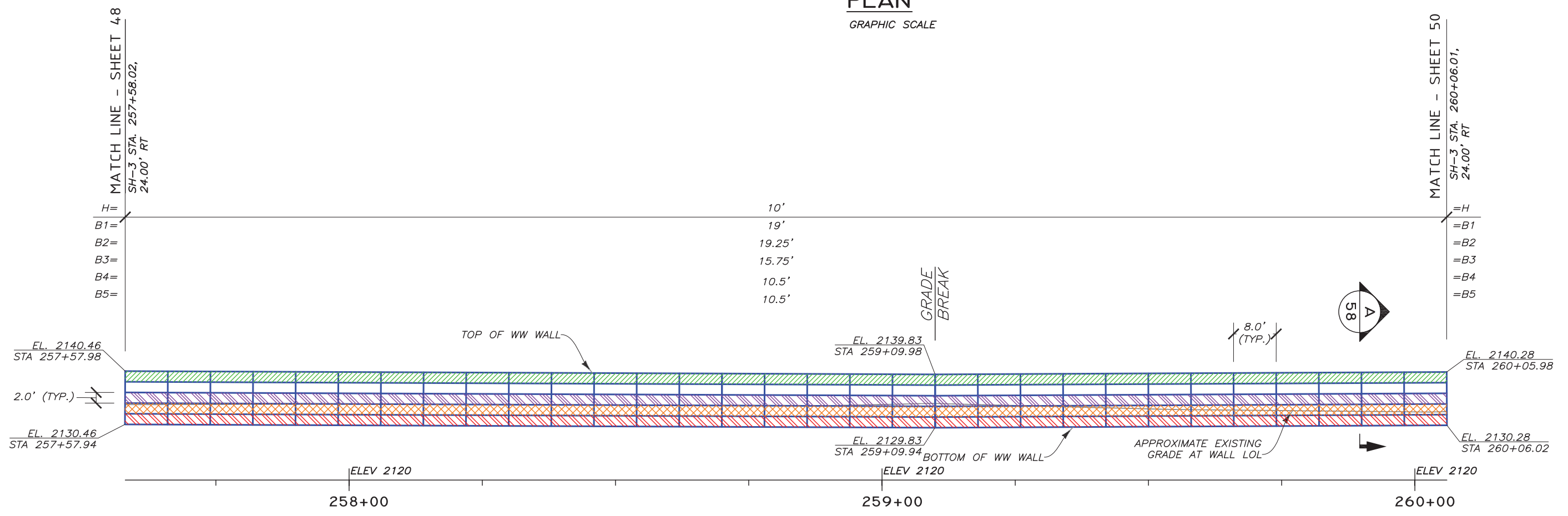

**DEVELOPED ELEVATION - (FRONT FACE)**  
GRAPHIC SCALE

**LEGEND**

	B1	8"X12", W7xW3.5-HDG	LOL	LAYOUT LINE
	B2	8"X21", W4.5xW4-HDG	H	WALL HEIGHT (BOTTOM MAT TO CAP MAT)
	B3	8"X21", W4.5xW4-HDG (W/GEOFOAM)	B	MAT LENGTH
	B4	8"X21", W4.5xW4-HDG (W/GEOFOAM)	WW	WELDED WIRE
	B5	8"X21", W4.5xW4-HDG		

REV.	DATE	BY	DESCRIPTION	CADD:
0	12/30/2021	RGV	ISSUED FOR OWNER REVIEW	RGV
1	2/4/2022	RGV	ISSUED FOR OWNER REVIEW IN RESPONSE TO COMMENTS	RGV
				CHECKED: SGC

**HILFIKER RETAINING WALLS**

1902 Hilfiker Lane  
Eureka, CA 95503-5711  
TOLL-FREE 800.762.8962  
PH 707.443.5093 FAX 707.443.2891  
WEB SITE www.hilfiker.com E-MAIL info@hilfiker.com

**AMERICAN GEOTECHNICS**

American Geotechnics  
5260 Chinden Blvd.  
Boise, ID 83714  
(208) 658-8700  
Fax: (208) 658-8703

PLAN & ELEVATION  
WW WALL  
SH-3, GOOSEHAVEN RD.  
TO ROUND LAKE RD.  
ITD BENEWAH COUNTY, ID

DWG DATE: 4 FEB 2022
HRW NO.: 210714AW
SHEET 49
OF 61

PROFESSIONAL ENGINEER  
2/4/2022  
15993  
AN G. VAN LEUVEN

03584-SH-3\_Goosehaven\_Rd\_ID\_PREP\_2-4-2022.dwg  
2/4/2022 10:54 AM  
RVanLeuven

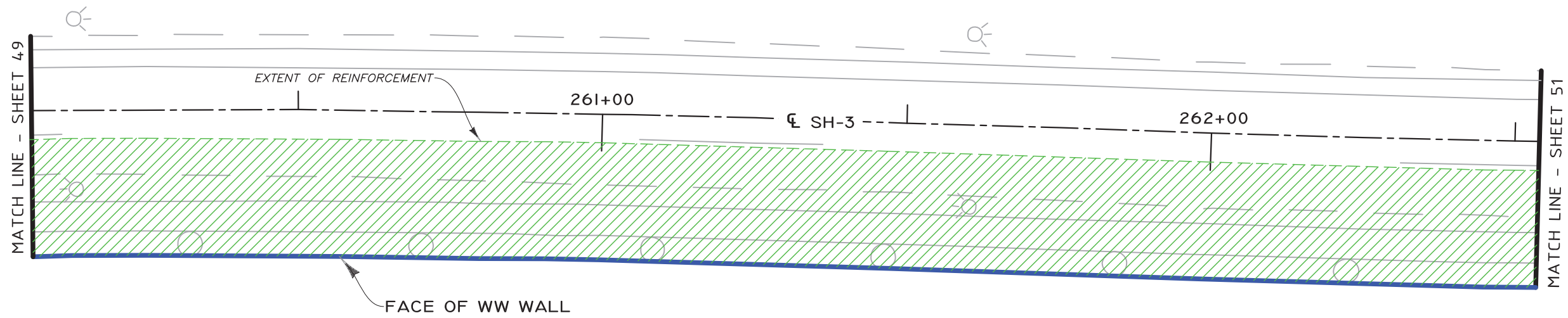
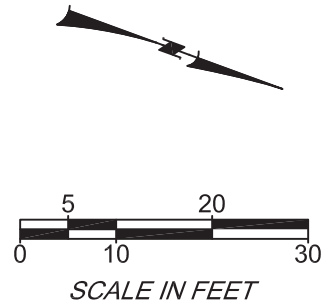

**PLAN**  
GRAPHIC SCALE

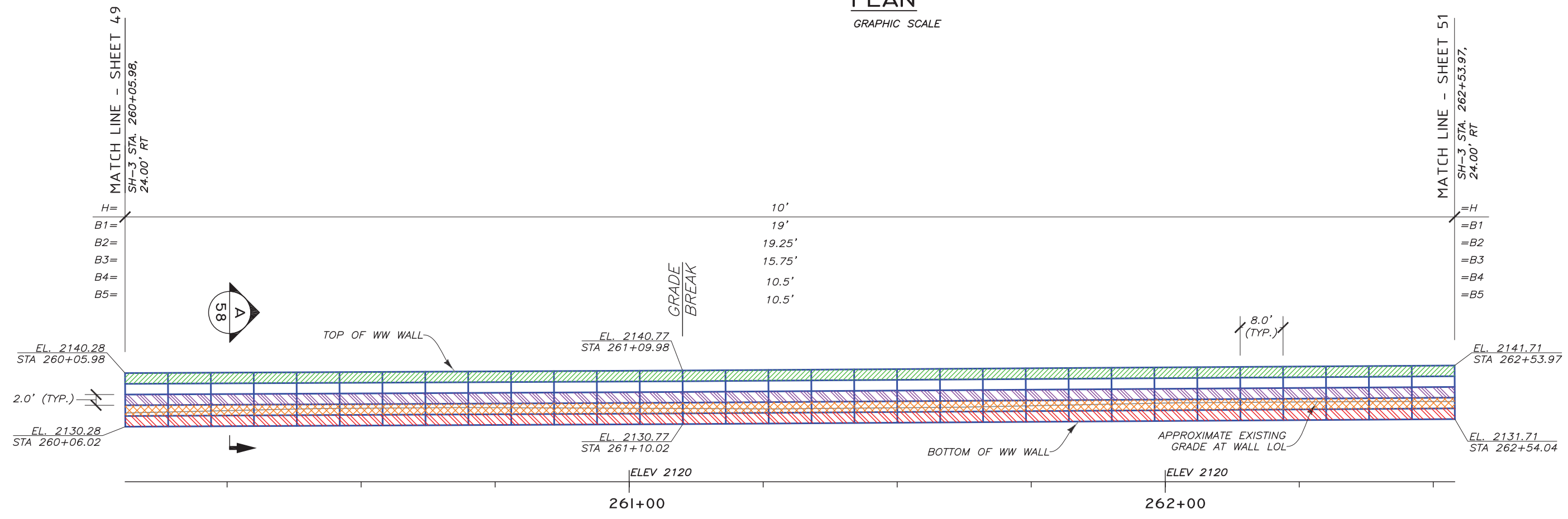

**DEVELOPED ELEVATION - (FRONT FACE)**  
GRAPHIC SCALE

**LEGEND**

	B1	8"x12", W7xW3.5-HDG	LOL	LAYOUT LINE
	B2	8"x21", W4.5xW4-HDG	H	WALL HEIGHT (BOTTOM MAT TO CAP MAT)
	B3	8"x21", W4.5xW4-HDG (W/GEOFOAM)	B	MAT LENGTH
	B4	8"x21", W4.5xW4-HDG (W/GEOFOAM)	WW	WELDED WIRE
	B5	8"x21", W4.5xW4-HDG		

REV.	DATE	BY	DESCRIPTION	CADD:
0	12/30/2021	RGV	ISSUED FOR OWNER REVIEW	RGV
1	2/4/2022	RGV	ISSUED FOR OWNER REVIEW IN RESPONSE TO COMMENTS	RGV
				CHECKED: SGC

**HILFIKER RETAINING WALLS**

1902 Hilfiker Lane  
Eureka, CA 95503-5711  
TOLL-FREE 800.752.8962  
PH 707.443.5093 FAX 707.443.2891  
WEB SITE www.hilfiker.com E-MAIL info@hilfiker.com

**AMERICAN GEOTECHNICS**

American Geotechnics  
5260 Chinden Blvd.  
Boise, ID 83714  
(208) 658-8700  
Fax: (208) 658-8703

PLAN & ELEVATION  
WW WALL  
SH-3, GOOSEHAVEN RD.  
TO ROUND LAKE RD.  
ITD BENEWAH COUNTY, ID

DWG DATE: 4 FEB 2022  
HRW NO.: 210714AW  
SHEET 50 OF 61

PROFESSIONAL ENGINEER  
2/4/2022  
15993  
  
ALAN G. VAN LEUVEN  
STATE OF IDAHO

03584-SH-3\_Goosehaven\_Rd\_ID\_PREP\_2-4-2022.dwg  
2/4/2022 10:54 AM  
RVanLeuven

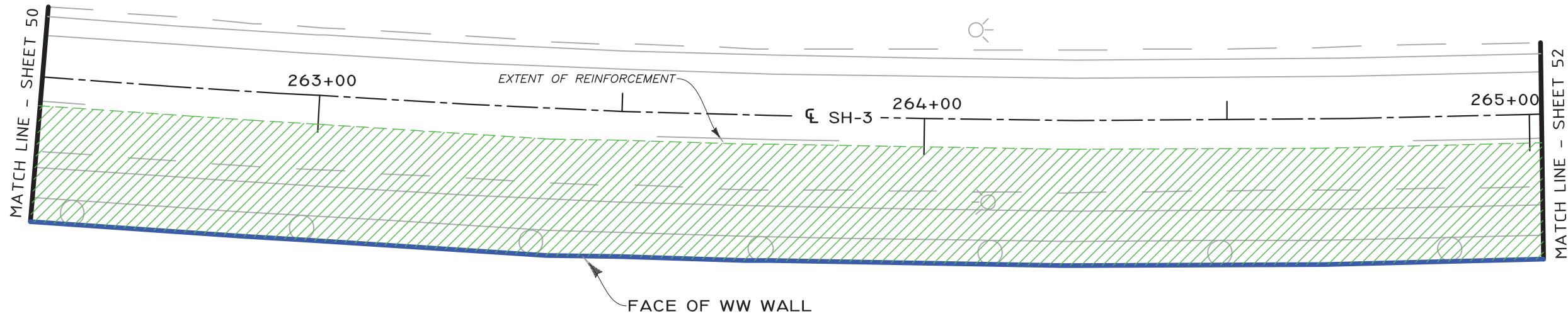
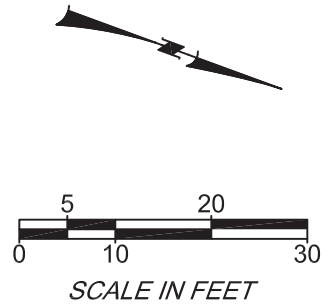

**PLAN**  
GRAPHIC SCALE

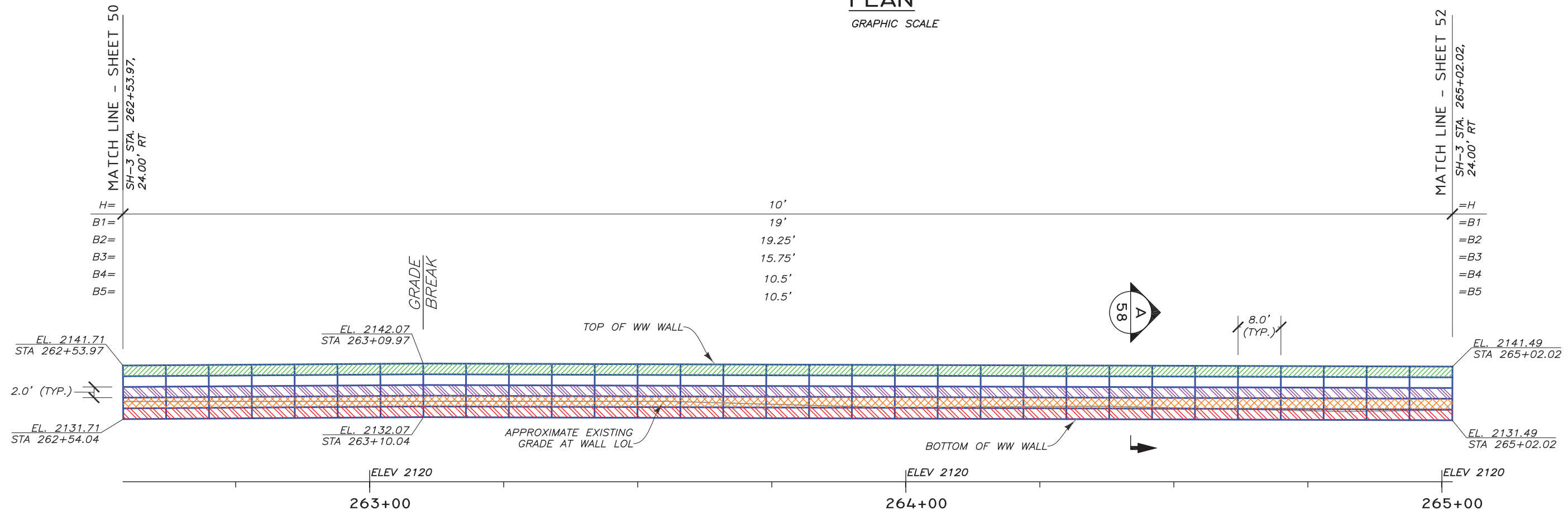

**DEVELOPED ELEVATION - (FRONT FACE)**  
GRAPHIC SCALE

LEGEND			
	B1 8"x12", W7xW3.5-HDG	LOL	LAYOUT LINE
	B2 8"x21", W4.5xW4-HDG	H	WALL HEIGHT (BOTTOM MAT TO CAP MAT)
	B3 8"x21", W4.5xW4-HDG (W/GEOFOAM)	B	MAT LENGTH
	B4 8"x21", W4.5xW4-HDG (W/GEOFOAM)	WW	WELDED WIRE
	B5 8"x21", W4.5xW4-HDG		

03584-SH-3\_Goosehaven\_Rd\_I1\_PREP 2-4-2022.dwg  
2/4/2022 10:54 AM  
RVanLeuven

REV.	DATE	BY	DESCRIPTION	CADD:
0	12/30/2021	RGV	ISSUED FOR OWNER REVIEW	RGV
1	2/4/2022	RGV	ISSUED FOR OWNER REVIEW IN RESPONSE TO COMMENTS	RGV
				CHECKED: SGC

**HILFIKER RETAINING WALLS**

1902 Hilfiker Lane  
Eureka, CA 95503-5711  
TOLL-FREE 800.762.8962  
PH 707.443.5093 FAX 707.443.2891  
WEB SITE www.hilfiker.com E-MAIL info@hilfiker.com

**AMERICAN GEOTECHNICS**

American Geotechnics  
5260 Chinden Blvd.  
Boise, ID 83714  
(208) 658-8700  
Fax: (208) 658-8703

PLAN & ELEVATION	
WW WALL	
SH-3, GOOSEHAVEN RD. TO ROUND LAKE RD.	
ITD	BENEWAH COUNTY, ID

DWG DATE:	4 FEB 2022
HRW NO.:	210714AW
SHEET	51
OF	61

PROFESSIONAL ENGINEER  
2/4/2022  
15993  
G. VAN LEUVEN  
STATE OF IDAHO

03584-SH-3\_Goosehaven\_Rd\_ID PREP 2-4-2022.dwg  
2/4/2022 10:54 AM  
RVanLeuven

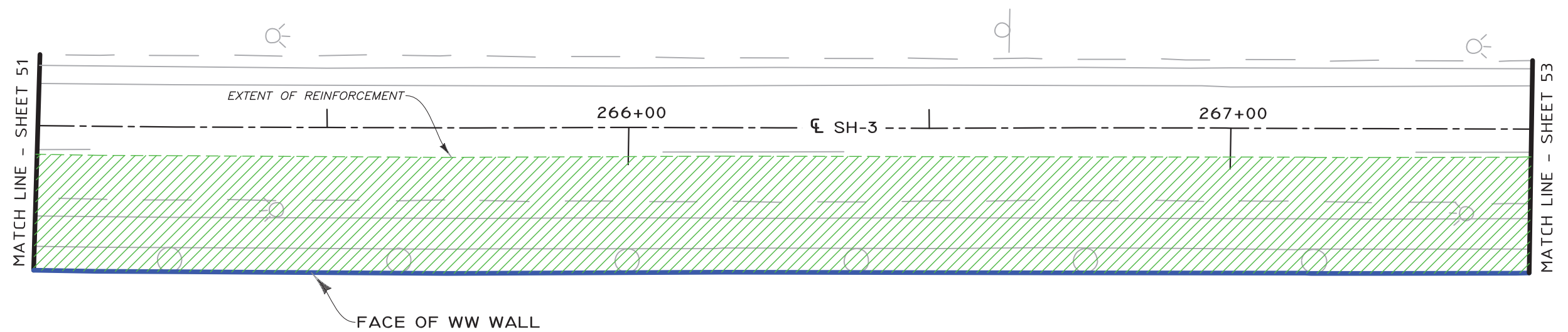
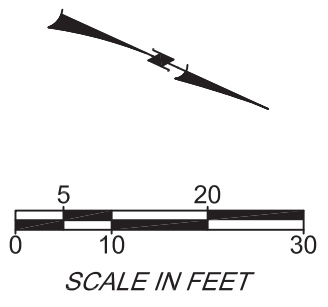

**PLAN**  
GRAPHIC SCALE

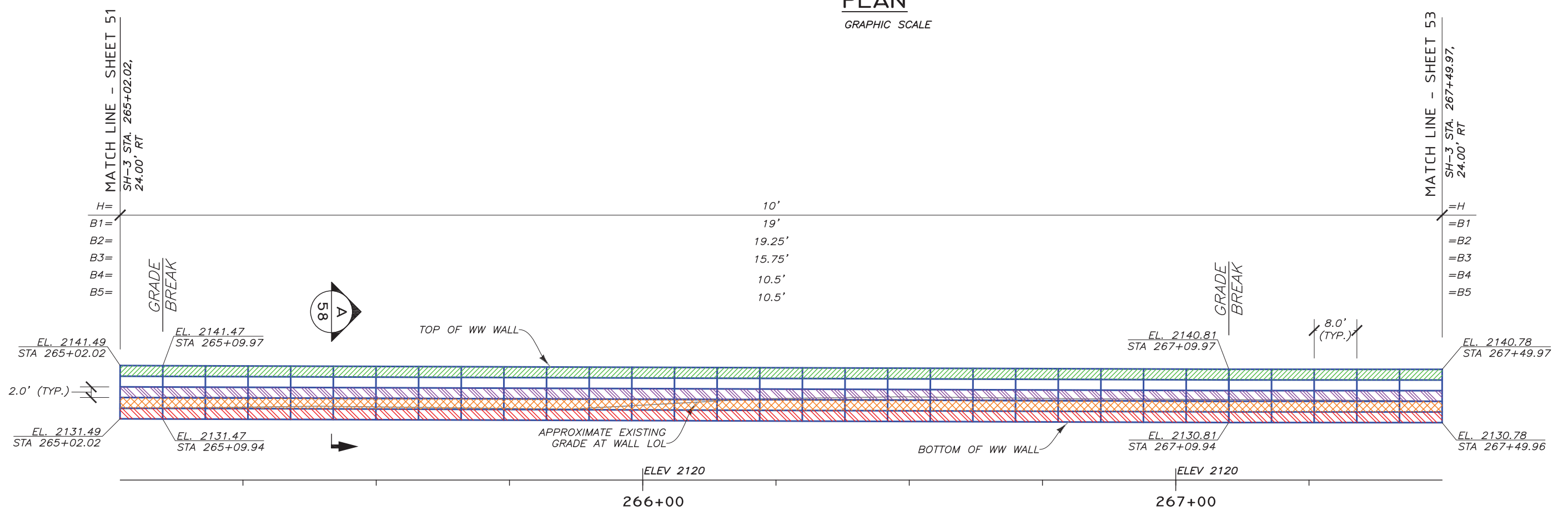

**DEVELOPED ELEVATION - (FRONT FACE)**  
GRAPHIC SCALE

**LEGEND**

	B1	8"X12", W7xW3.5-HDG	LOL	LAYOUT LINE
	B2	8"X21", W4.5xW4-HDG	H	WALL HEIGHT (BOTTOM MAT TO CAP MAT)
	B3	8"X21", W4.5xW4-HDG (W/GEOFOAM)	B	MAT LENGTH
	B4	8"X21", W4.5xW4-HDG (W/GEOFOAM)	WW	WELDED WIRE
	B5	8"X21", W4.5xW4-HDG		

REV.	DATE	BY	DESCRIPTION	CADD:
0	12/30/2021	RGV	ISSUED FOR OWNER REVIEW	RGV
1	2/4/2022	RGV	ISSUED FOR OWNER REVIEW IN RESPONSE TO COMMENTS	RGV
				CHECKED: SGC

**HILFIKER RETAINING WALLS**

1902 Hilfiker Lane  
Eureka, CA 95503-5711  
TOLL-FREE 800.752.8962  
PH 707.443.5093 FAX 707.443.2891  
WEB SITE www.hilfiker.com E-MAIL info@hilfiker.com

**AMERICAN GEOTECHNICS**

American Geotechnics  
5260 Chinden Blvd.  
Boise, ID 83714  
(208) 658-8700  
Fax: (208) 658-8703

PLAN & ELEVATION  
WW WALL  
SH-3, GOOSEHAVEN RD.  
TO ROUND LAKE RD.  
ITD BENEWAH COUNTY, ID

DWG DATE:  
4 FEB 2022  
HRW NO.:  
210714AW  
SHEET  
52  
OF 61

PROFESSIONAL ENGINEER  
2/4/2022  
15993  
G. VAN LEUVEN  
STATE OF IDAHO

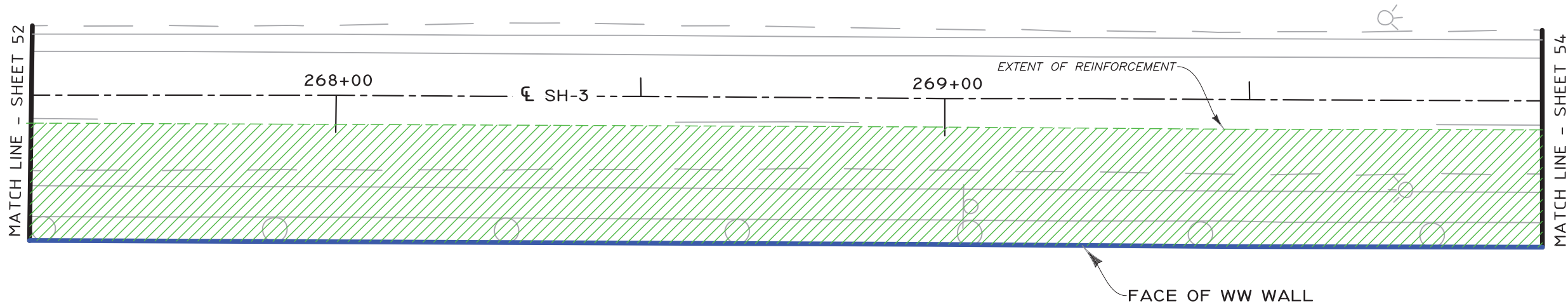
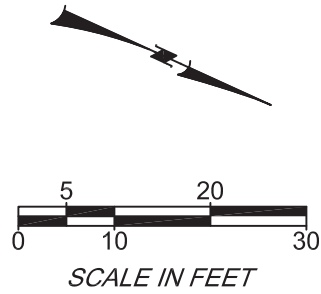

**PLAN**  
GRAPHIC SCALE

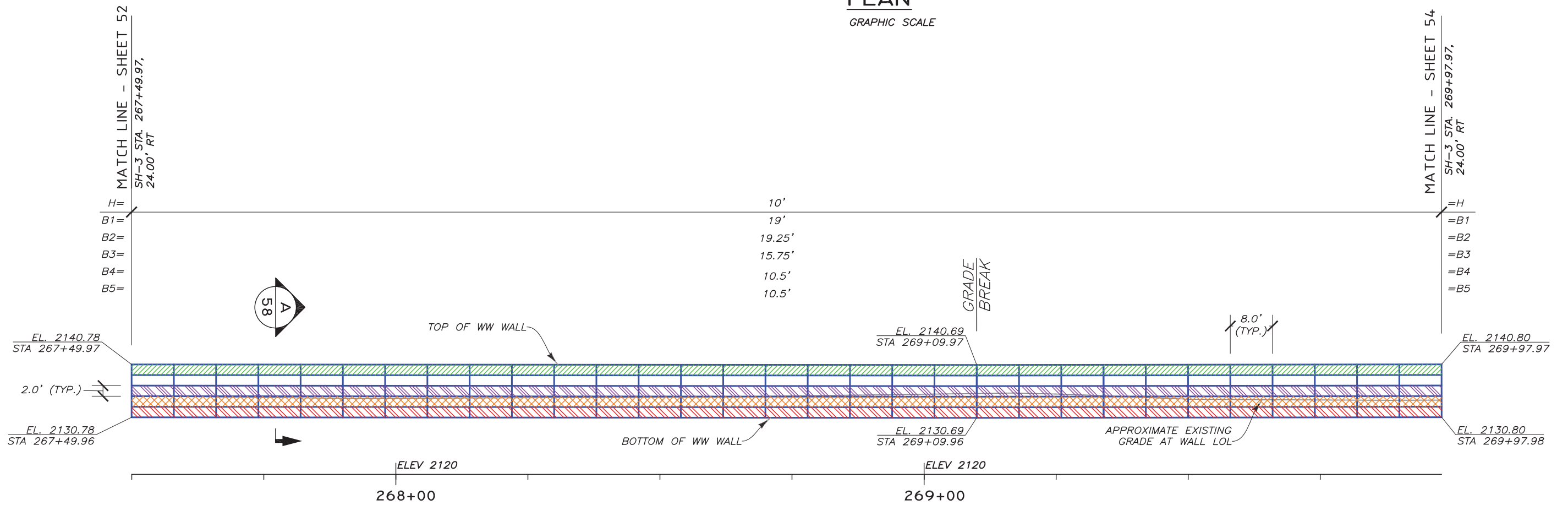

**DEVELOPED ELEVATION - (FRONT FACE)**

GRAPHIC SCALE

**LEGEND**

	B1	8"x12", W7xW3.5-HDG	LOL	LAYOUT LINE
	B2	8"x21", W4.5xW4-HDG	H	WALL HEIGHT (BOTTOM MAT TO CAP MAT)
	B3	8"x21", W4.5xW4-HDG (W/GEOFOAM)	B	MAT LENGTH
	B4	8"x21", W4.5xW4-HDG (W/GEOFOAM)	WW	WELDED WIRE
	B5	8"x21", W4.5xW4-HDG		

03584-SH-3\_Goosehaven\_Rd\_ID PREP 2-4-2022.dwg  
2/4/2022 10:54 AM  
RVanLeuven

REV.	DATE	BY	DESCRIPTION	CADD:
0	12/30/2021	RGV	ISSUED FOR OWNER REVIEW	RGV
1	2/4/2022	RGV	ISSUED FOR OWNER REVIEW IN RESPONSE TO COMMENTS	DESIGNED: RGV CHECKED: SGC

**HILFIKER RETAINING WALLS**

1902 Hilfiker Lane  
Eureka, CA 95503-5711  
TOLL-FREE 800.762.8962  
PH 707.443.5093 FAX 707.443.2891  
WEB SITE www.hilfiker.com EMAIL info@hilfiker.com

**AMERICAN GEOTECHNICS**

American Geotechnics  
5260 Chinden Blvd.  
Boise, ID 83714  
(208) 658-8700  
Fax: (208) 658-8703

PLAN & ELEVATION	DWG DATE: 4 FEB 2022
WW WALL	HRW NO.:
SH-3, GOOSEHAVEN RD. TO ROUND LAKE RD.	210714AW
ITD	SHEET 53
BENEWAH COUNTY, ID	OF 61

PROFESSIONAL ENGINEER

2/4/2022

15993

STATE OF IDAHO

AN G. VAN LEUVEN

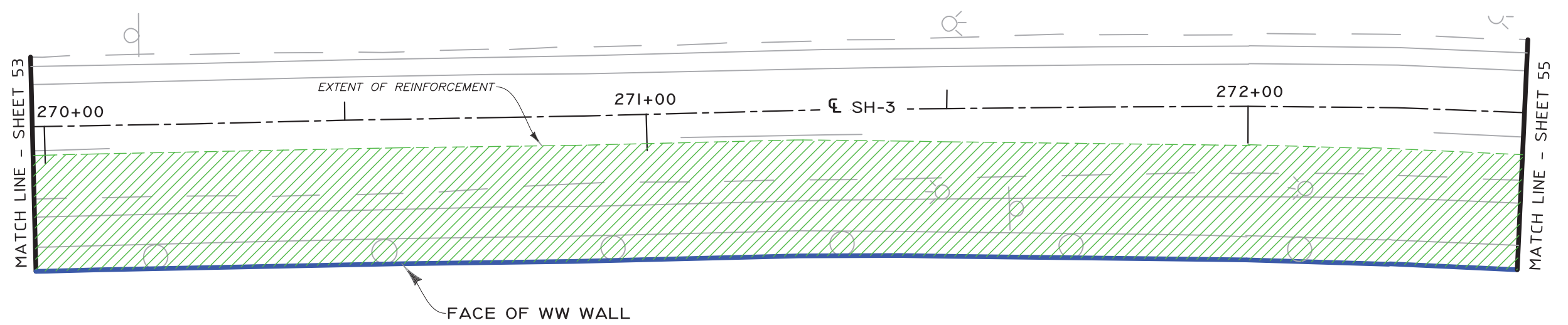
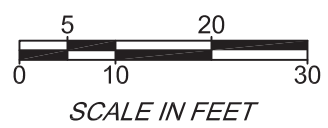

**PLAN**  
GRAPHIC SCALE

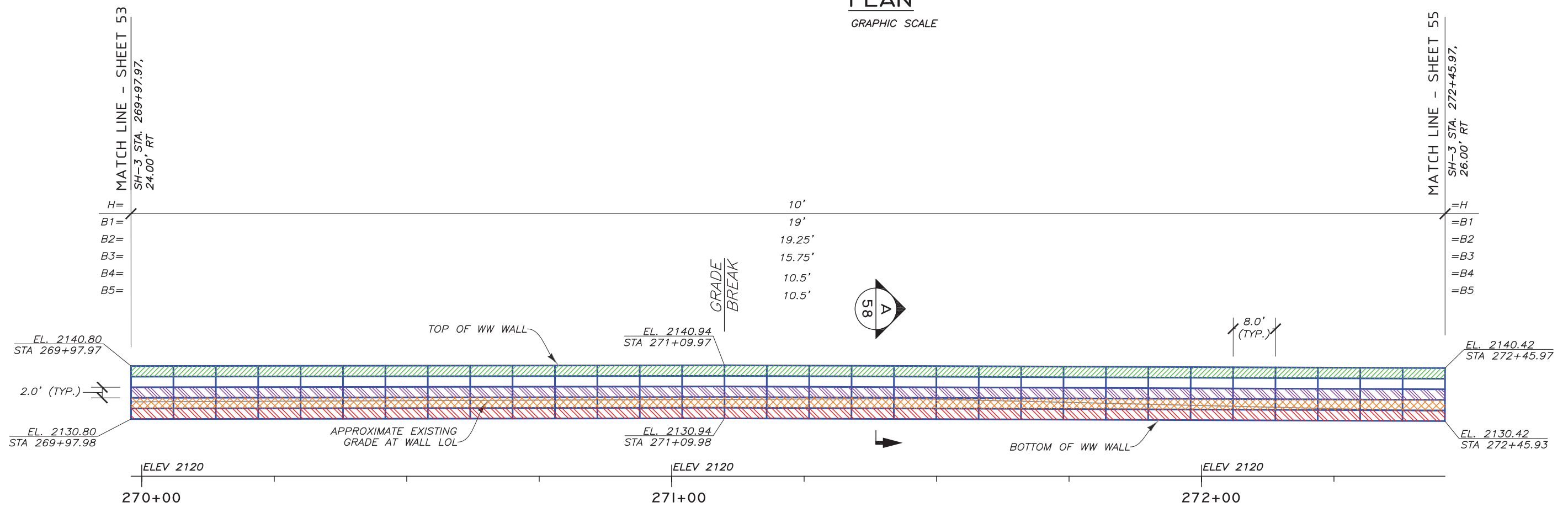

**DEVELOPED ELEVATION - (FRONT FACE)**  
GRAPHIC SCALE

**LEGEND**

	B1	8"x12", W7xW3.5-HDG	LOL	LAYOUT LINE
	B2	8"x21", W4.5xW4-HDG	H	WALL HEIGHT (BOTTOM MAT TO CAP MAT)
	B3	8"x21", W4.5xW4-HDG (W/GEOFOAM)	B	MAT LENGTH
	B4	8"x21", W4.5xW4-HDG (W/GEOFOAM)	WW	WELDED WIRE
	B5	8"x21", W4.5xW4-HDG		

THE DESIGN CONTAINED ON THESE DRAWINGS IS BASED ON INFORMATION PROVIDED BY THE OWNER. ON THE BASIS OF THIS INFORMATION, THE HILFIKER COMPANY HAS DESIGNED, AND IS RESPONSIBLE FOR THE INTERNAL STABILITY OF THE STRUCTURE ONLY. EXTERNAL STABILITY, INCLUDING FOUNDATION AND SLOPE STABILITY, IS THE RESPONSIBILITY OF THE OWNER.

REV.	DATE	BY	DESCRIPTION
0	12/30/2021	RGV	ISSUED FOR OWNER REVIEW
1	2/4/2022	RGV	ISSUED FOR OWNER REVIEW IN RESPONSE TO COMMENTS

CADD:	RGV
DESIGNED:	RGV
CHECKED:	SGC

**HILFIKER RETAINING WALLS**

1902 HilfiKER Lane  
Eureka, CA 95503-5711  
TOLL-FREE 800.752.8962  
PH 707.443.5093 FAX 707.443.2891  
WEB SITE www.hilfiKER.com E-MAIL info@hilfiKER.com

**AMERICAN GEOTECHNICS**

American Geotechnics  
5260 Chinden Blvd.  
Boise, ID 83714  
(208) 658-8700  
Fax: (208) 658-8703

PLAN & ELEVATION	
WW WALL	
SH-3, GOOSEHAVEN RD. TO ROUND LAKE RD.	
ITD	BENEWAH COUNTY, ID

DWG DATE:	4 FEB 2022
HRW NO.:	210714AW
SHEET	54
OF	61

PROFESSIONAL ENGINEER

2/4/2022

15993

STATE OF IDAHO

G. VAN LEUVEN

03584-SH-3\_Goosehaven\_Rd\_ID\_PREP 2-4-2022.dwg  
2/4/2022 10:54 AM  
RVanLeuven

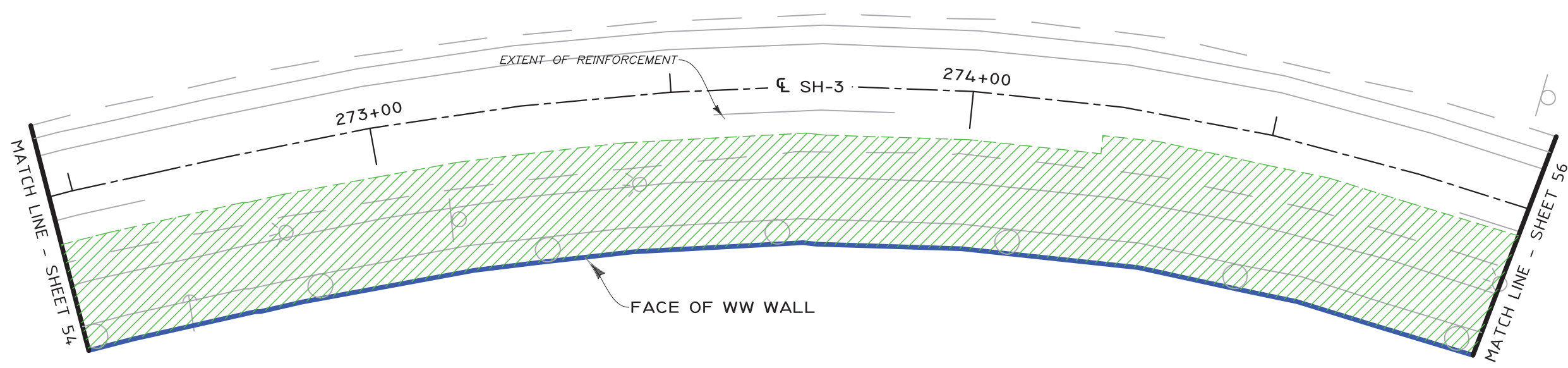
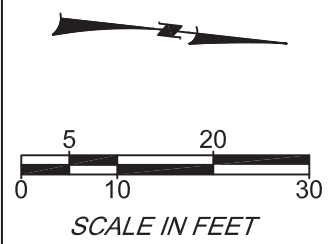

**PLAN**  
GRAPHIC SCALE

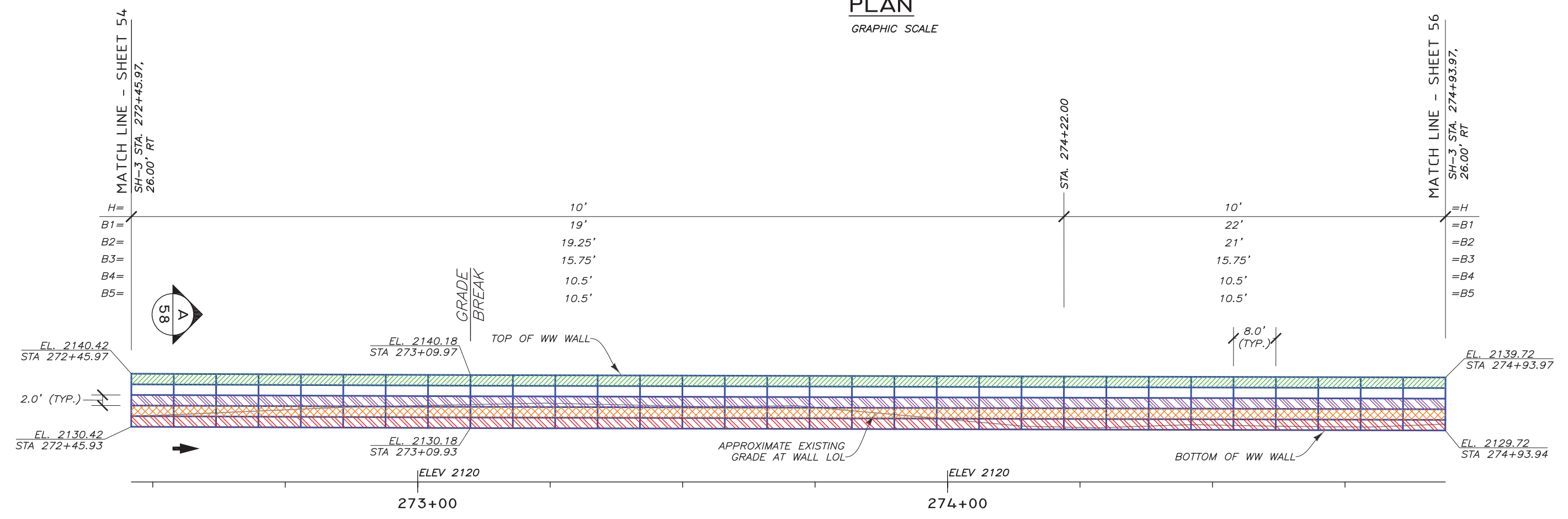

**DEVELOPED ELEVATION - (FRONT FACE)**  
GRAPHIC SCALE

LEGEND		
	B1 8"x12", W7xW3.5-HDG	LOL LAYOUT LINE
	B2 8"x21", W4.5xW4-HDG	H WALL HEIGHT (BOTTOM MAT TO CAP MAT)
	B3 8"x21", W4.5xW4-HDG (W/GEOFOAM)	B MAT LENGTH
	B4 8"x21", W4.5xW4-HDG (W/GEOFOAM)	WW WELDED WIRE
	B5 8"x21", W4.5xW4-HDG	

03584 - SF-3 - Goosehaven Rd. JT PREP 2-28-2022.dwg  
2/28/2022 11:11 AM  
Ryan Leuven

REV.	DATE	BY	DESCRIPTION	CADD:
0	12/30/2021	RGV	ISSUED FOR OWNER REVIEW	RGV
1	2/4/2022	RGV	ISSUED FOR OWNER REVIEW IN RESPONSE TO COMMENTS	DESIGNED: RGV
2	2/28/2022	RGV	ISSUED FOR OWNER REVIEW IN RESPONSE TO COMMENTS	CHECKED: SGC

**HILFIKER RETAINING WALLS**

1902 Hilfiker Lane  
Eureka, CA 95503-5711  
TOLL FREE 800.762.8962  
PH 707.443.5093 FAX 707.443.2891  
WEBSITE www.hilfiker.com E-MAIL info@hilfiker.com

**AMERICAN GEOTECHNICS**

American Geotechnics  
5260 Chinden Blvd.  
Boise, ID 83714  
(208) 658-8700  
Fax: (208) 658-8703

PLAN & ELEVATION	DWG DATE: 28 FEB 2022
WW WALL	HRW NO.:
SH-3, GOOSEHAVEN RD. TO ROUND LAKE RD.	210714AW
ITD	SHEET 55 OF 61
BENEWAH COUNTY, ID	

PROFESSIONAL ENGINEER  
2/28/2022  
15993  
RYAN G. VAN LEUVEN  
STATE OF IDAHO

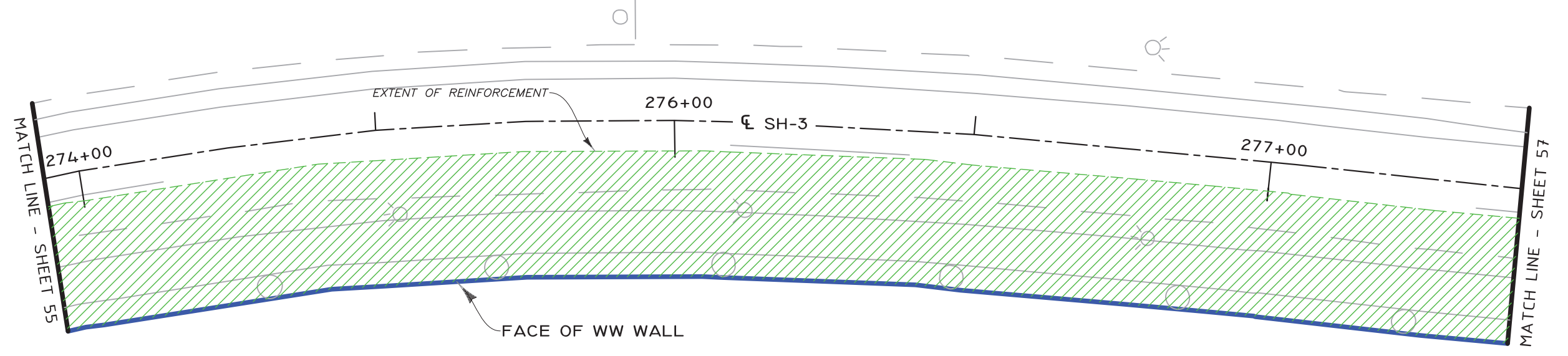
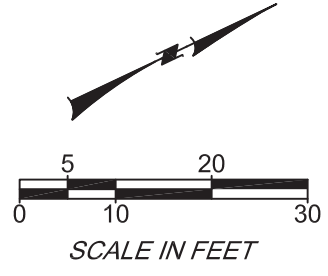

**PLAN**  
GRAPHIC SCALE

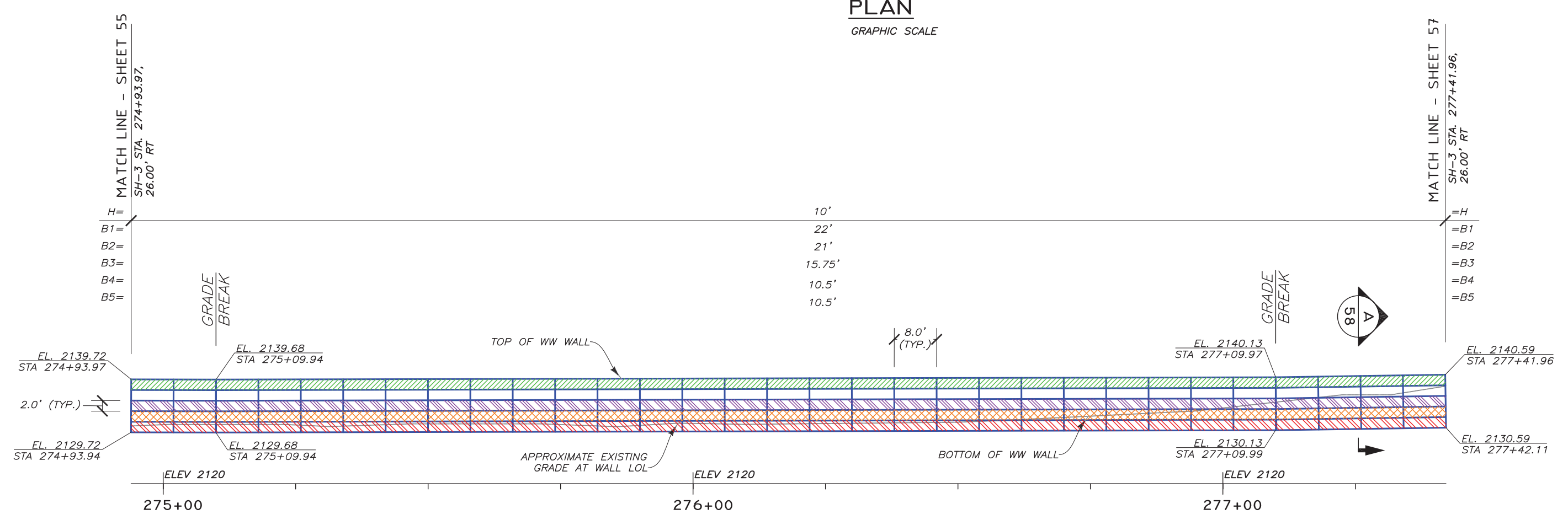

**DEVELOPED ELEVATION - (FRONT FACE)**  
GRAPHIC SCALE

**LEGEND**

	B1	8"x12", W7xW3.5-HDG	LOL	LAYOUT LINE
	B2	8"x21", W4.5xW4-HDG	H	WALL HEIGHT (BOTTOM MAT TO CAP MAT)
	B3	8"x21", W4.5xW4-HDG (W/GEOFOAM)	B	MAT LENGTH
	B4	8"x21", W4.5xW4-HDG (W/GEOFOAM)	WW	WELDED WIRE
	B5	8"x21", W4.5xW4-HDG		

03584\_S1-3\_Goosehaven\_Rd\_I1\_PREP 2-4-2022.dwg  
2/4/2022 10:54 AM  
RVanLeuven

THE DESIGN CONTAINED ON THESE DRAWINGS IS BASED ON INFORMATION PROVIDED BY THE OWNER. ON THE BASIS OF THIS INFORMATION, THE HILFIKER COMPANY HAS DESIGNED, AND IS RESPONSIBLE FOR THE INTERNAL STABILITY OF THE STRUCTURE ONLY. EXTERNAL STABILITY, INCLUDING FOUNDATION AND SLOPE STABILITY, IS THE RESPONSIBILITY OF THE OWNER.

REV.	DATE	BY	DESCRIPTION
0	12/30/2021	RGV	ISSUED FOR OWNER REVIEW
1	2/4/2022	RGV	ISSUED FOR OWNER REVIEW IN RESPONSE TO COMMENTS

CADD: RGV  
DESIGNED: RGV  
CHECKED: SGC

**HILFIKER RETAINING WALLS**

1902 Hilfiker Lane  
Eureka, CA 95503-5711  
TOLL-FREE 800.762.8962  
PH 707.443.5093 FAX 707.443.2891  
WEB SITE www.hilfiker.com EMAIL info@hilfiker.com

**AMERICAN GEOTECHNICS**

American Geotechnics  
5260 Chinden Blvd.  
Boise, ID 83714  
(208) 658-8700  
Fax: (208) 658-8703

PLAN & ELEVATION	DWG DATE: 4 FEB 2022
WW WALL	HRW NO.: 210714AW
SH-3, GOOSEHAVEN RD. TO ROUND LAKE RD.	SHEET 56 OF 61
ITD	BENEWAH COUNTY, ID

PROFESSIONAL ENGINEER  
2/4/2022  
15993  
N. G. VAN LEUVEN  
STATE OF IDAHO



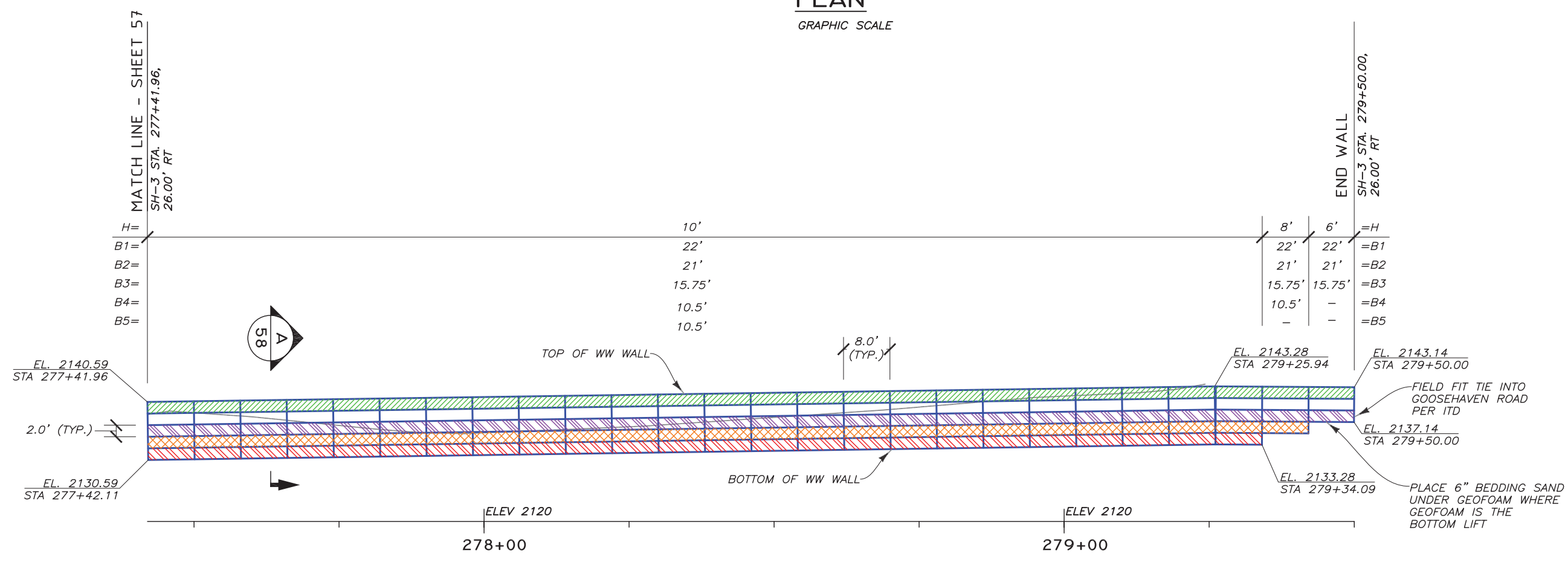
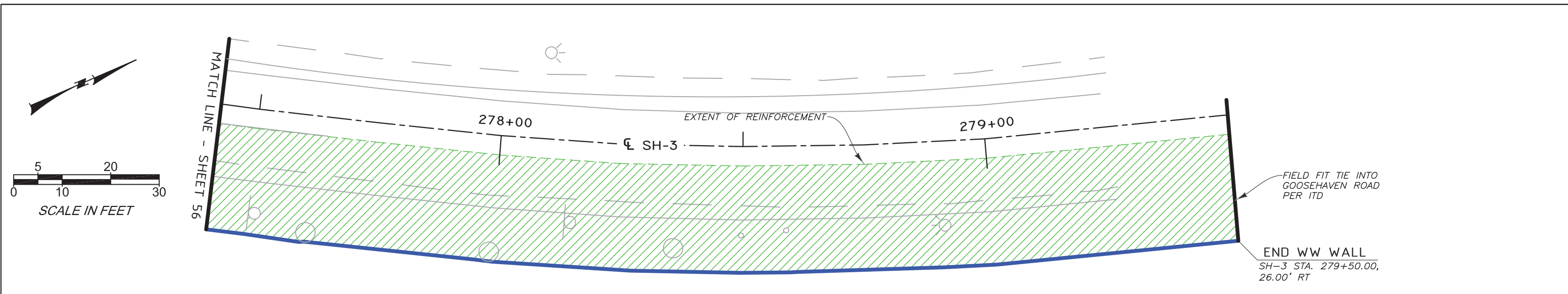

**LEGEND**

	B1	8"X12", W7xW3.5-HDG	LOL	LAYOUT LINE
	B2	8"X21", W4.5xW4-HDG	H	WALL HEIGHT (BOTTOM MAT TO CAP MAT)
	B3	8"X21", W4.5xW4-HDG (W/GEOFOAM)	B	MAT LENGTH
	B4	8"X21", W4.5xW4-HDG (W/GEOFOAM)	WW	WELDED WIRE
	B5	8"X21", W4.5xW4-HDG		

**DEVELOPED ELEVATION - (FRONT FACE)**  
GRAPHIC SCALE

03584 - SH-3, Goosehaven Rd., IT PREP 2-28-2022.dwg  
2/28/2022 11:11 AM  
RVanLeuven

REV.	DATE	BY	DESCRIPTION
0	12/30/2021	RGV	ISSUED FOR OWNER REVIEW
1	2/4/2022	RGV	ISSUED FOR OWNER REVIEW IN RESPONSE TO COMMENTS
2	2/28/2022	RGV	ISSUED FOR OWNER REVIEW IN RESPONSE TO COMMENTS

CADD: RGV  
DESIGNED: RGV  
CHECKED: SGC

**HILFIKER RETAINING WALLS**

1902 HilfiKER Lane  
Eureka, CA 95503-5711  
TOLL FREE 800.762.8962  
PH 707.443.5093 FAX 707.443.2891  
WEBSITE www.hilfiKER.com E-MAIL info@hilfiKER.com

**1902**  
SINCE 1902

**AMERICAN GEOTECHNICS**

American Geotechnics  
5260 Chinden Blvd.  
Boise, ID 83714  
(208) 658-8700  
Fax: (208) 658-8703

PLAN & ELEVATION	DWG DATE: 28 FEB 2022
WW WALL	HRW NO.: 210714AW
SH-3, GOOSEHAVEN RD. TO ROUND LAKE RD.	SHEET 57 OF 61
ITD	BENEWAH COUNTY, ID

**PROFESSIONAL ENGINEER**

2/28/2022

15993

*R. VAN LEUVEN*

STATE OF IDAHO

**R. VAN LEUVEN**

03584\_S1-3\_Goosehaven Rd. I PREP 2-4-2022.dwg

2/4/2022 10:54 AM

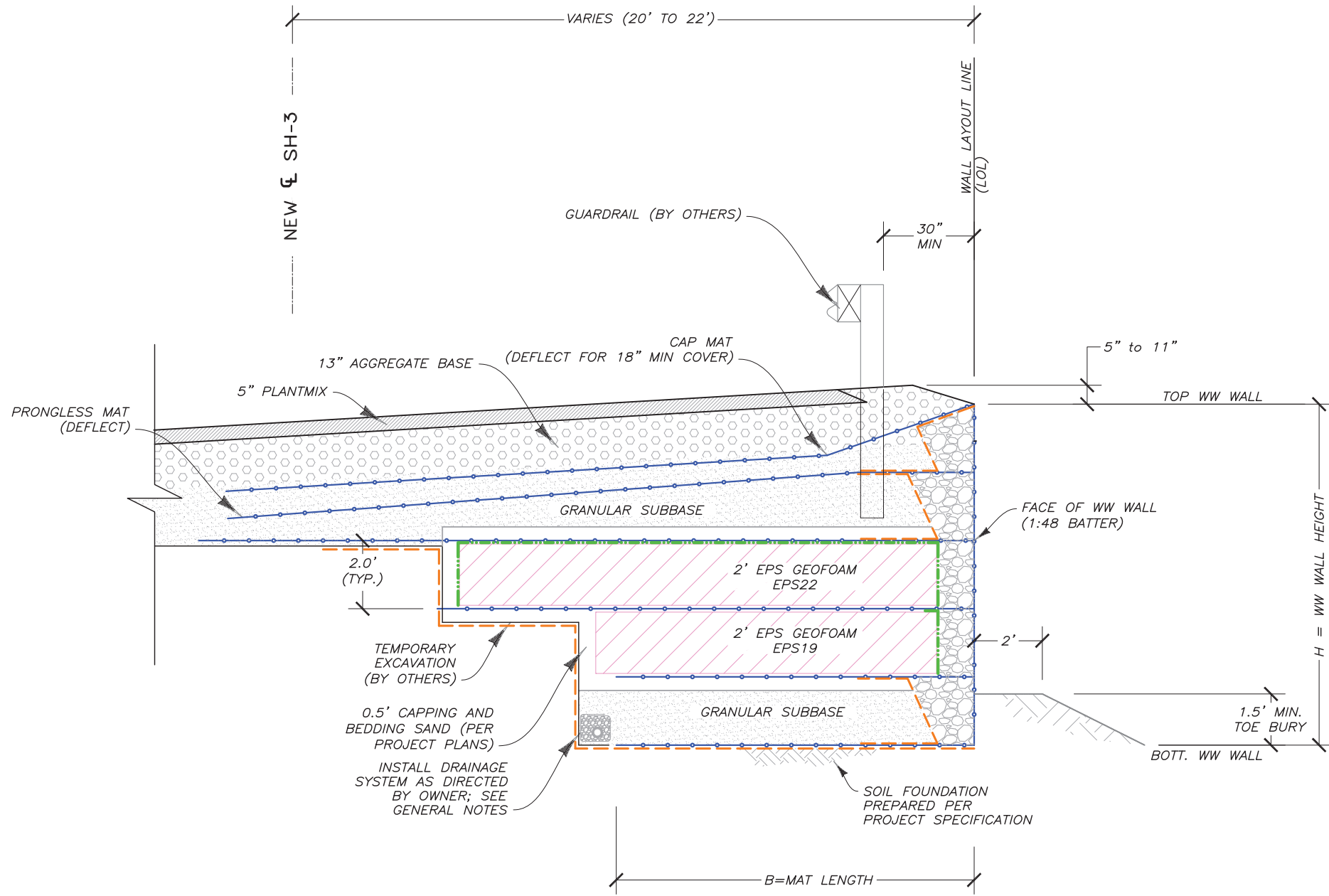

**TYPICAL SECTION** A  
NOT TO SCALE 2-57

**LEGEND**

- WW REINFORCEMENT AND FACING
- SUBGRADE SEPARATION GEOTEXTILE
- HYDROCARBON RESISTANT GEOMEMBRANE
- GEOFOAM

THE DESIGN CONTAINED ON THESE DRAWINGS IS BASED ON INFORMATION PROVIDED BY THE OWNER. ON THE BASIS OF THIS INFORMATION, THE HILFIKER COMPANY HAS DESIGNED, AND IS RESPONSIBLE FOR THE INTERNAL STABILITY OF THE STRUCTURE ONLY. EXTERNAL STABILITY, INCLUDING FOUNDATION AND SLOPE STABILITY, IS THE RESPONSIBILITY OF THE OWNER.

REV.	DATE	BY	DESCRIPTION	CADD:
0	12/30/2021	RGV	ISSUED FOR OWNER REVIEW	RGV
1	2/4/2022	RGV	ISSUED FOR OWNER REVIEW IN RESPONSE TO COMMENTS	DESIGNED: RGV CHECKED: SGC

**HILFIKER RETAINING WALLS**

1902 Hilfiker Lane  
Eureka, CA 95503-5711  
TOLL-FREE 800.762.8962  
PH 707.443.5093 FAX 707.443.2891  
WEB SITE www.hilfiker.com E-MAIL info@hilfiker.com

**AMERICAN  
GEO  
TECHNICS**

American Geotechnics  
5260 Chinden Blvd.  
Boise, ID 83714  
(208) 658-8700  
Fax: (208) 658-8703

SECTIONS	DWG DATE:
WW WALL	4 FEB 2022
SH-3, GOOSEHAVEN RD. TO ROUND LAKE RD.	HRW NO.: 210714AW
ITD	SHEET 58
BENEWAH COUNTY, ID	OF 61

PROFESSIONAL ENGINEER

2/4/2022

15993

STATE OF IDAHO

G. VAN LEUVEN

03584\_SH-3\_Goosehaven Rd. I PREP 2-4-2022.dwg

2/4/2022 10:54 AM

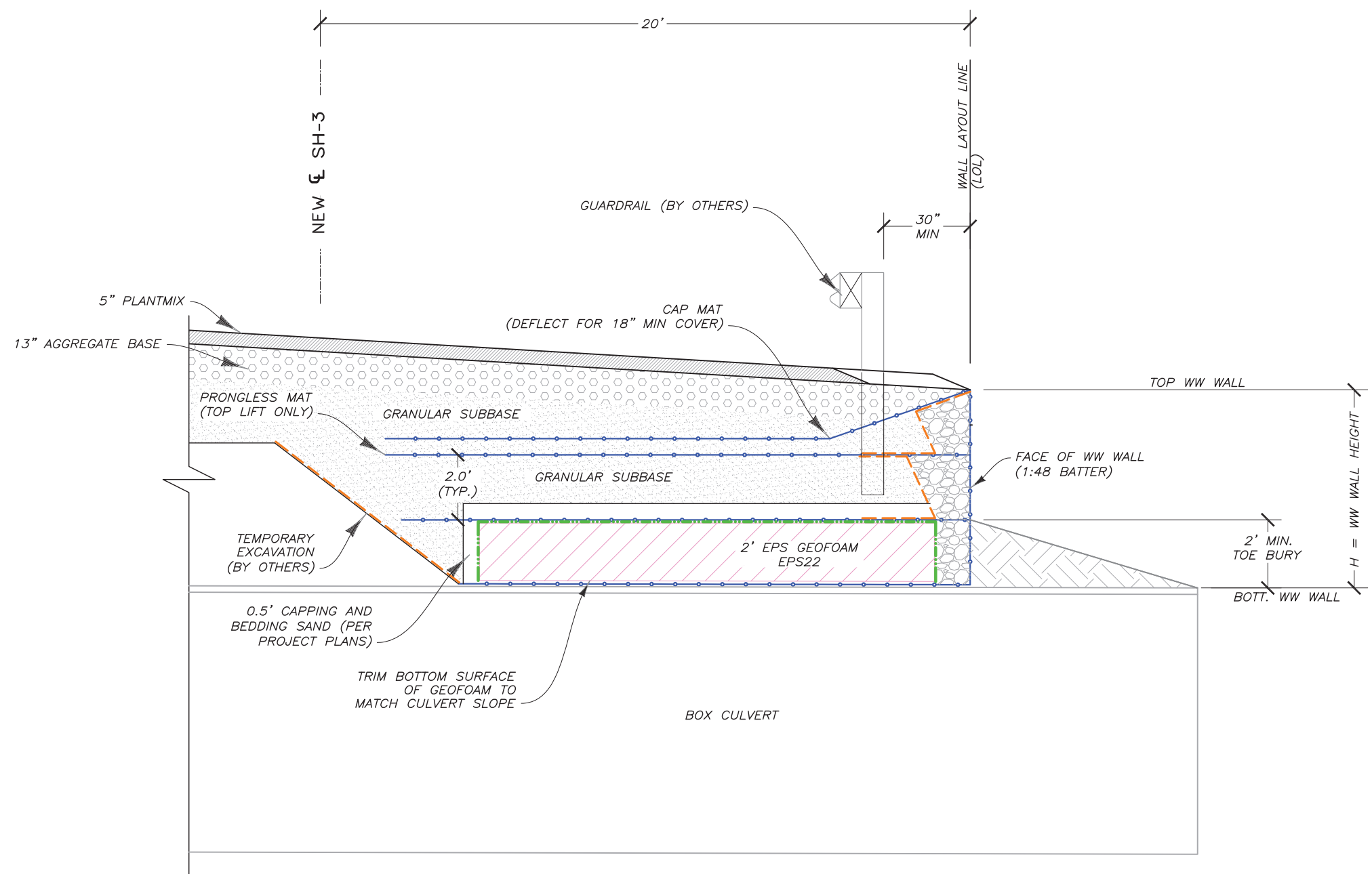

**TYPICAL SECTION** C  
5  
NOT TO SCALE

**LEGEND**

	WW REINFORCEMENT AND FACING
	SUBGRADE SEPARATION GEOTEXTILE
	HYDROCARBON RESISTANT GEOMEMBRANE
	GEOFOAM

REV.	DATE	BY	DESCRIPTION	CADD:
0	12/30/2021	RGV	ISSUED FOR OWNER REVIEW	RGV
1	2/4/2022	RGV	ISSUED FOR OWNER REVIEW IN RESPONSE TO COMMENTS	DESIGNED: RGV CHECKED: SGC

**HILFIKER RETAINING WALLS**

**HW**

1902 Hilfiiker Lane  
Eureka, CA 95503-5711  
TOLL-FREE 800.762.8962  
PH 707.443.5093 FAX 707.443.2891  
WEB SITE www.hilfiiker.com E-MAIL info@hilfiiker.com

**1902**

**AMERICAN  
GEO  
TECHNICS**

American Geotechnics  
5260 Chinden Blvd.  
Boise, ID 83714  
(208) 658-8700  
Fax: (208) 658-8703

SECTIONS	DWG DATE:
WW WALL	4 FEB 2022
SH-3, GOOSEHAVEN RD. TO ROUND LAKE RD.	HRW NO.: 210714AW
ITD	SHEET 59 OF 61

BENEWAH COUNTY, ID

PROFESSIONAL ENGINEER

2/4/2022

15993

STATE OF IDAHO

AN G. VAN LEUVEN

AT THE UPPER SURFACE OF THE CULVERT, CUT THE TRANSVERSE WIRES ONLY. BEND AND LIFT THE LONGITUDINAL WIRES IN THE BASE OF THE MAT TO FIT AGAINST THE SIDE OF THE CULVERT

ANY LARGE GAP AT THE TOP OF THE CULVERT MAY BE CLOSED WITH BACKING MAT AND HARDWARE CLOTH, CUT TO FIT, OR USE LARGER ROCKS OR SACKED CONCRETE

AT THE LOWER SURFACE OF THE CULVERT, CUT THE TRANSVERSE WIRES ONLY IN THE MAT FACE. BEND THE LONGITUDINAL WIRES BACK TO FIT AGAINST THE CURVE OF THE CULVERT

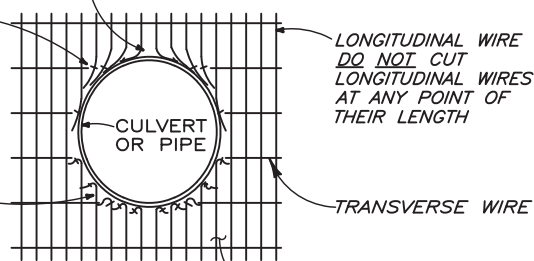

NOTE: BACKING MATS AND HARDWARE CLOTH (NOT SHOWN) ARE TO BE CUT OFF FLUSH WITH THE SIDES OF THE CULVERT

**ELEVATION**  
**CULVERT THRU WALL FACE**  
NOT TO SCALE

**STEP 4**  
PLACE AND COMPACT BACKFILL OVER THE SLOPED CAPS TO FINAL GRADE

**STEP 2**  
PLACE CAPS ON SLOPE

**STEP 1**  
CUT OFF TOP OF THE MAT FACES, BACKING MATS AND FILTER FABRIC PARALLEL TO FINAL GRADE

NOTE: USE 3' BACKING MATS WHEN NECESSARY TO AVOID TRIMMING PRONGLESS MAT IN EXCESS OF 12" VERTICAL

**STEP 3**  
CLIP CAPS TO MAT FACES WITH HOG-RINGS

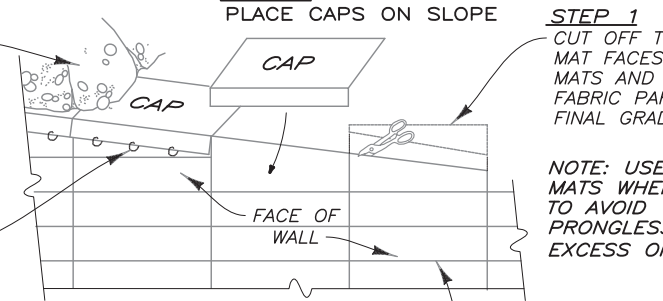

**PICTORIAL ELEVATION**  
**SLOPED CAP MAT DETAIL**  
NOT TO SCALE

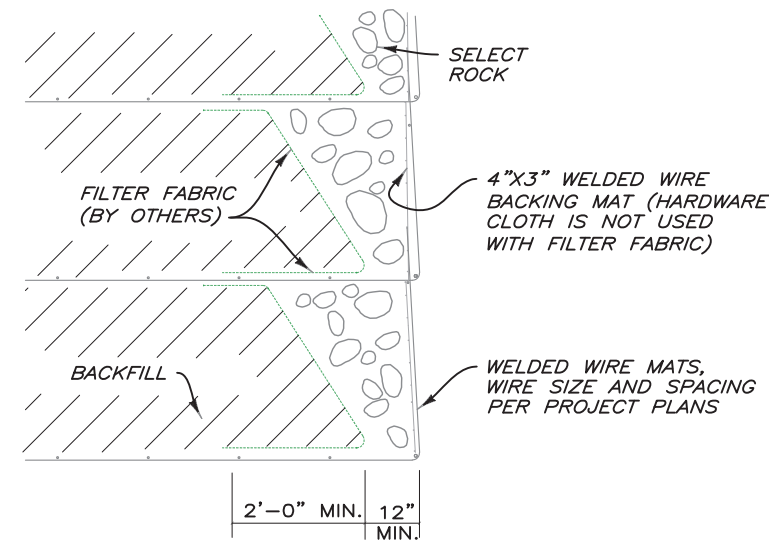

**SECTION**  
**ROCK FACING DETAIL**  
NOT TO SCALE

FOR A SMOOTHER CURVE, SPLIT THE MAT BASES AND BEND THE FACES. DO NOT SPLIT MAT FACES OR CUT LONGITUDINAL WIRES

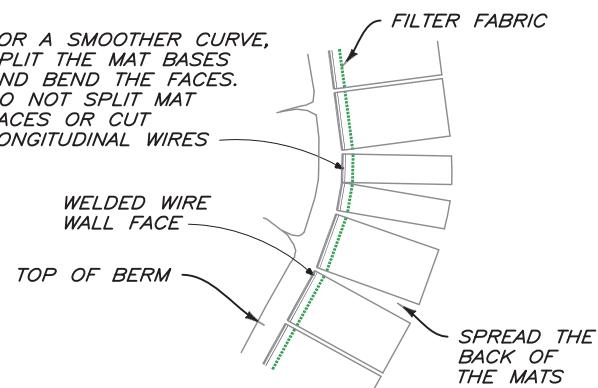

**PLAN VIEW**  
**CONCAVE CURVE**  
NOT TO SCALE

FOR A SMOOTHER CURVE SPLIT THE MAT BASES AND BEND THE FACES. DO NOT SPLIT MAT FACES OR CUT LONGITUDINAL WIRES

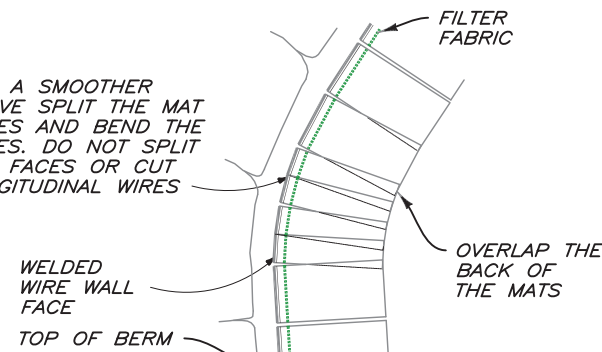

**PLAN VIEW**  
**CONVEX CURVE**  
NOT TO SCALE

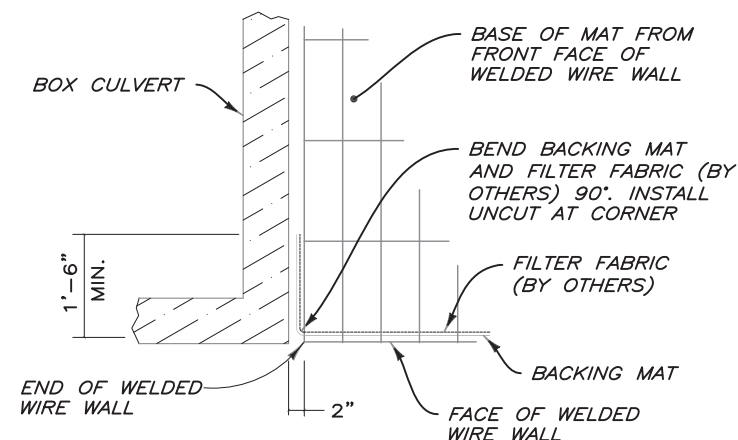

**PLAN VIEW**  
**WELDED WIRE WALL**  
**END AT BOX CULVERT**  
NOT TO SCALE

03584\_S11-3\_Goosehaven\_Rd\_11\_PREP 2-4-2022.dwg

RVanLeuven 2/4/2022 10:54 AM

REV.	DATE	BY	DESCRIPTION	CADD:
0	12/30/2021	RGV	ISSUED FOR OWNER REVIEW	RGV
1	2/4/2022	RGV	ISSUED FOR OWNER REVIEW	DESIGNED: RGV
			IN RESPONSE TO COMMENTS	CHECKED: SGC

**HILFIKER RETAINING WALLS**



1902 HilfiKER Lane  
Eureka, CA 95503-5711  
TOLL-FREE 800.762.8962  
PH 707.443.5093 FAX 707.443.2891  
WEB SITE www.hilfiKER.com EMAIL info@hilfiKER.com



American Geotechnics  
5260 Chinden Blvd.  
Boise, ID 83714  
(208) 658-8700  
Fax: (208) 658-8703

SECTIONS	
ITD	BENEWAH COUNTY, ID

DWG DATE:	4 FEB 2022
HRW NO.:	210714AW
SHEET	60
OF	61

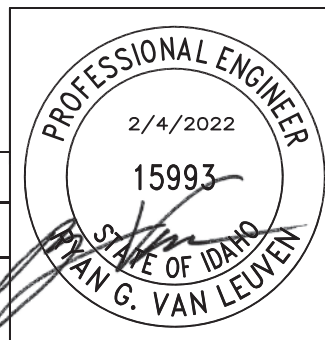

**STEP 1**

PLACE THE FIRST COURSE OF SOIL REINFORCEMENT MATS ON PREPARED FOUNDATION

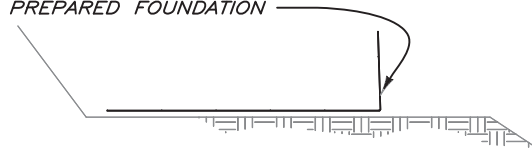

**STEP 2**

PLACE THE BACKING MAT AGAINST THE INSIDE FACE OF THE SOIL REINFORCEMENT MAT. CLIP THE SECOND-TO-TOP TRANSVERSE WIRE ON THE BACKING MAT TO THE TOP TRANSVERSE WIRE ON THE SOIL REINFORCEMENT MAT.

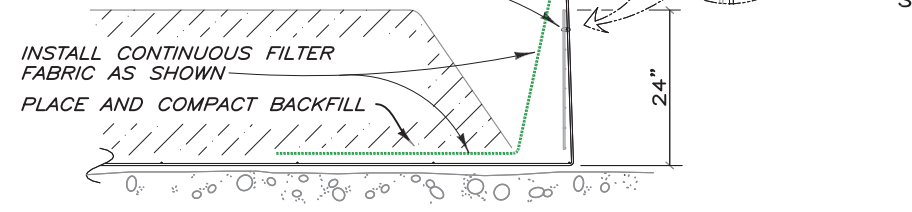

**STEP 3**

BRING THE FILTER FABRIC OVER THE FRONT AND TOP OF THE BACKFILL AS SHOWN. PLACE THE ROCK IN THE FACE OF THE WALL. LEAVE A VOID AS SHOWN.

PLACE THE SECOND COURSE OF SOIL REINFORCEMENT MATS WITH THE BASE LONGITUDINAL WIRES RESTING ON THE TOP TRANSVERSE WIRE OF THE BACKING MAT BELOW. SLIDE THE SOIL REINFORCEMENT MAT INTO ALIGNMENT.

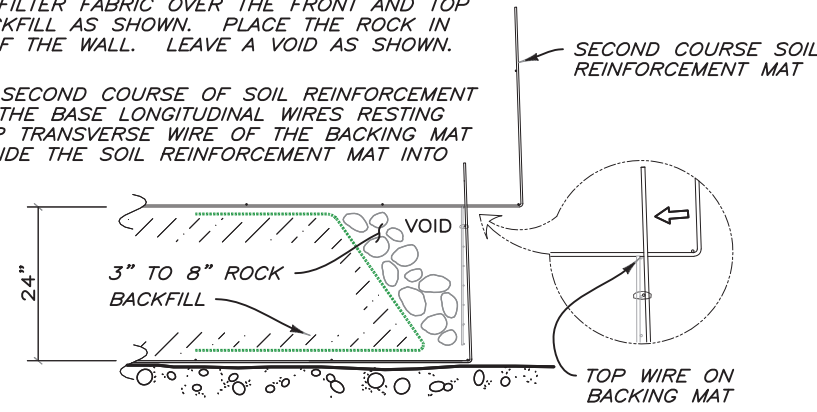

**STEP 4**

HOOK THE BOTTOM TRANSVERSE WIRE OF THE BACKING MAT OVER THE VERTICAL PRONGS ON THE LOWER MAT. ROTATE THE BACKING MAT TO VERTICAL AND CLIP THE SECOND-TO-TOP TRANSVERSE WIRE ON THE BACKING MAT TO THE TOP WIRE ON THE SOIL REINFORCEMENT MAT.

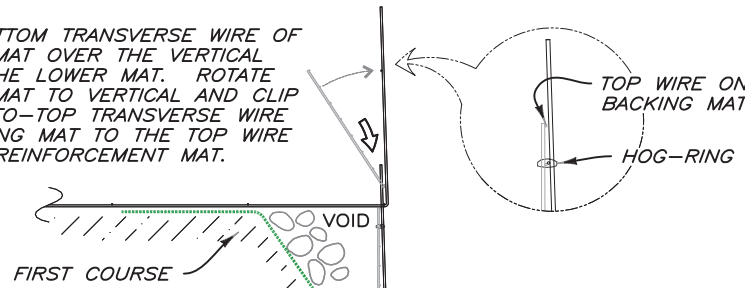

**STEP 5**

INSTALL THE FILTER FABRIC AS IN STEPS 2 AND 3. PLACE AND COMPACT THE BACKFILL AND ROCK TO THE BASE ELEVATION OF THE NEXT MAT. REPEAT STEPS 2 THROUGH 5 TO THE TOP LIFT.

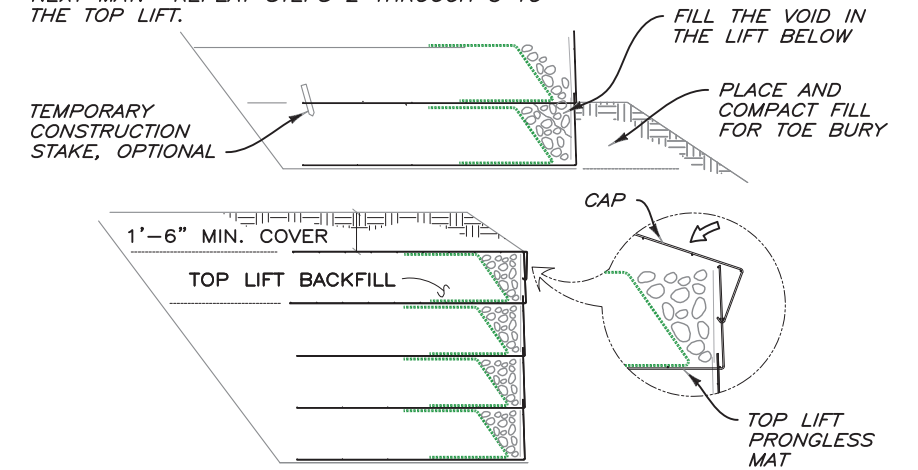

**STEP 6: TOP LIFT**

PLACE THE TOP LIFT PRONGLESS MAT, BACKING MAT AND FILTER FABRIC. PLACE AND COMPACT BACKFILL AND ROCK IN THE TOP LIFT. HOOK THE CAP OVER THE MIDDLE TRANSVERSE WIRE ON THE PRONGLESS MAT, AND ROTATE INTO PLACE. PLACE AND COMPACT COVER OVER TOP MAT TO 1'-6" MINIMUM DEPTH.

**CONSTRUCTION SEQUENCE**  
NOT TO SCALE

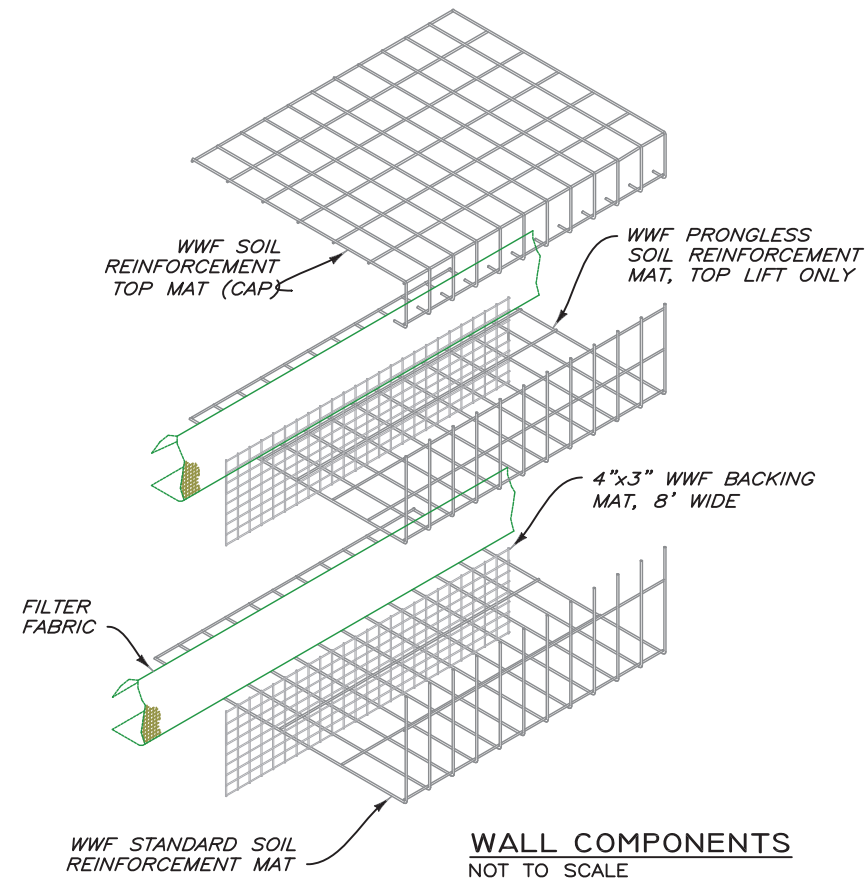

**WALL COMPONENTS**  
NOT TO SCALE

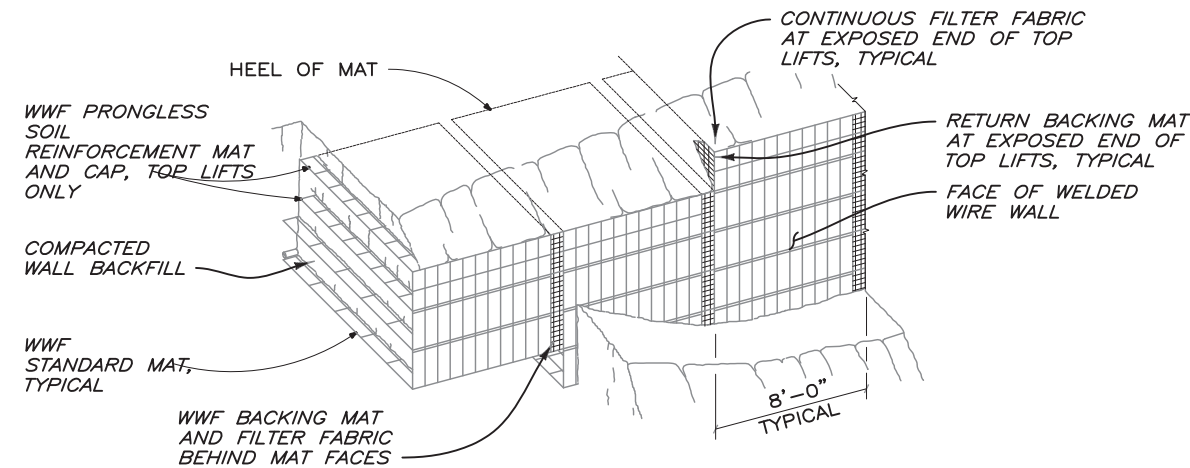

**PICTORIAL ELEVATION**  
NOT TO SCALE

REV.	DATE	BY	DESCRIPTION	CADD:
0	12/30/2021	RGV	ISSUED FOR OWNER REVIEW	RGV
1	2/4/2022	RGV	ISSUED FOR OWNER REVIEW	RGV
			IN RESPONSE TO COMMENTS	RGV
				SGC

**HILFIKER RETAINING WALLS**

1902 Hilfiaker Lane  
Eureka, CA 95503-5711  
TOLL-FREE 800.762.8962  
PH 707.443.5093 FAX 707.443.2891  
WEB SITE www.hilfiaker.com E-MAIL info@hilfiaker.com

**AMERICAN GEOTECHNICS**

American Geotechnics  
5260 Chinden Blvd.  
Boise, ID 83714  
(208) 658-8700  
Fax: (208) 658-8703

DETAILS	
SH-3, GOOSEHAVEN RD.	DWG DATE: 4 FEB 2022
TO ROUND LAKE RD.	HRW NO.: 210714AW
ITD	SHEET 61 OF 61
BENEWAH COUNTY, ID	

PROFESSIONAL ENGINEER

2/4/2022

15993

RYAN G. VAN LEUVEN

STATE OF IDAHO

03584-SH-3\_Goosehaven Rd., I PREP 2-4-2022.dwg  
2/4/2022 10:54 AM  
R/VanLeuven