

**NOTE:**  
ELEVATIONS ARE TO THE FACE OF  
THE PRIMARY MATS

LINE DESIGNATION	ELEVATION	SHEET NUMBER
S-01	166.59	7
S-02	168.74	7, 8
S-03	170.89	8, 9
S-04	173.04	9, 10, 11
S-05	175.18	11, 12
S-06	177.33	13, 14, 15
S-07	179.48	15, 16
S-08	181.62	17, 18, 19
S-09	183.77	19
S-10	185.91	20, 21, 22
S-11	188.06	22
S-12	190.20	23, 24, 25
S-13	192.35	25
S-14	194.50	26, 27, 28
S-15	196.64	28
S-16	198.79	29, 30, 31
S-17	200.94	31
S-18	203.08	32, 33
S-19	205.23	34, 35
	207.37	
S-20	209.52	36, 37
	211.66	
S-21	213.81	38, 39
	215.96	
S-22	218.10	40, 41
	220.25	
S-23	222.40	42
	224.54	
S-24	226.69	43
	228.83	
S-25	230.98	44
	233.12	
S-26	235.27	44
	237.42	
S-27	239.56	45
	241.71	
S-28	243.85	45

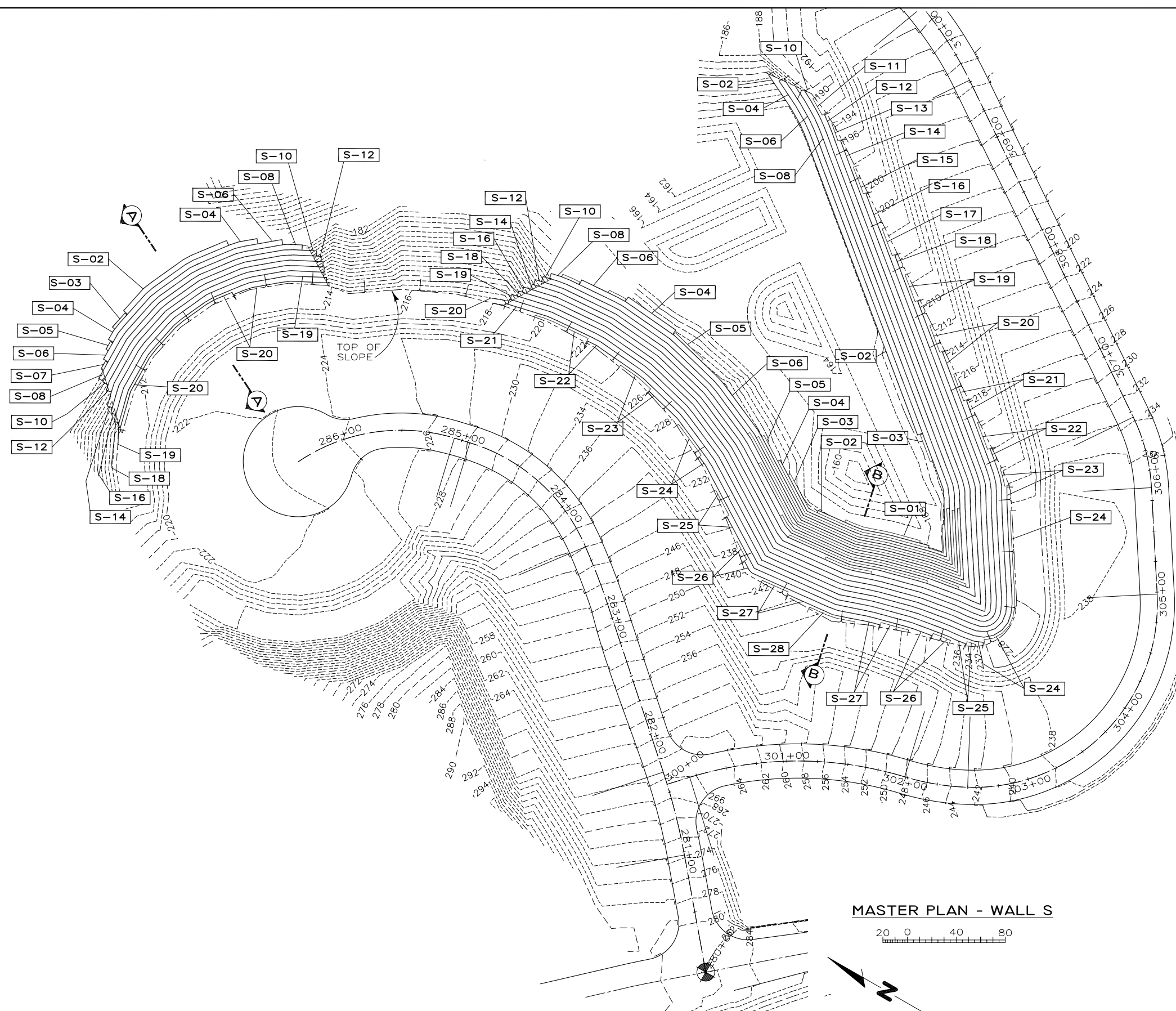

MASTER PLAN - WALL S

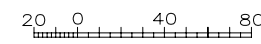

**PROJECT-SPECIFIC NOTES:**

1. REFERENCE DRAWINGS: OVERALL TOPO/CONTOUR MAP, IN ELECTRONIC FORMAT, RECEIVED APPROX. APRIL 2005, AND REVISED TOPO MAP "WALL S 072805.DWG" FROM CHRIS ZEPERNICK JULY 2005, ALONG WITH DESIGN SECTIONS BY SHN, ENGINEERS (SHEETS 4, 5 AND 6 OF THIS SET).
2. IT IS ASSUMED THAT ALL MATERIALS, BACKFILL AND CONSTRUCTION METHODS FOR HILFIKER M.S.E. WALLS WILL CONFORM TO HILFIKER'S SPECIFICATIONS AND/OR THOSE OF THE HILFIKER ENGINEERING CONSULTANT.
3. ALL INFORMATION HEREON IS DERIVED FROM THE REFERENCE DRAWINGS. THE APPLICABLE HILFIKER CONSTRUCTION GUIDE AND SPECIFICATIONS ARE AN INTEGRAL PART OF THIS SUBMITTAL.
4. SEE ALSO NOTES ON SHEET 4 OF THIS SET.

050329AS PANORAMA WALL S

THIS DRAWING IS FURNISHED SOLELY FOR THE USE OF OR IN CONNECTION WITH THIS PROJECT, AND THE PROPRIETARY INFORMATION SHOWN HEREON IS NOT TO BE TRANSMITTED TO ANY OTHER ORGANIZATION WITHOUT SPECIFIC AUTHORIZATION BY THE HILFIKER COMPANY. HILFIKER RETAINING WALLS ARE PROTECTED BY ONE OR MORE OF THE FOLLOWING PATENTS: 3,631,682, 4,117,686, 4,260,296, 4,329,089, 4,324,808, 4,343,572, 4,391,557, 4,505,621, 4,616,959, 4,643,618, 4,661,023, 4,856,939, 5,733,072 AND OTHERS PENDING.

REV. NO.	DATE	BY	DESCRIPTION
1	08/11/05	DR	MINOR REVISIONS, ADDITIONS

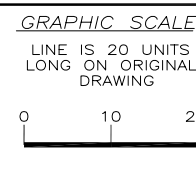

PROJ. MGR.  
WBH  
ENGINEER  
CADD BY  
DR

**HILFIKER RETAINING WALLS**  
3900 Broadway Eureka, CA 95503  
P.O. Box 2012 Eureka, CA 95501  
707-443-5093 Fax 707-443-2891  
Toll-Free 800-762-8962  
Web: <http://hilfiker.com> email: [info@hilfiker.com](mailto:info@hilfiker.com)



DWG DATE  
1 AUG 05  
REVISION DATE  
11 AUG 05  
SCALE  
NOTED

**SHOP DRAWING**  
STEEPENED SLOPE  
**PANORAMA WEST SUBDIVISION**  
WALL S  
PIERCE COUNTY, WASHINGTON  
WALL S - MASTER PLAN

PROJECT NO.  
050329AS  
SHEET  
**1**  
OF 45

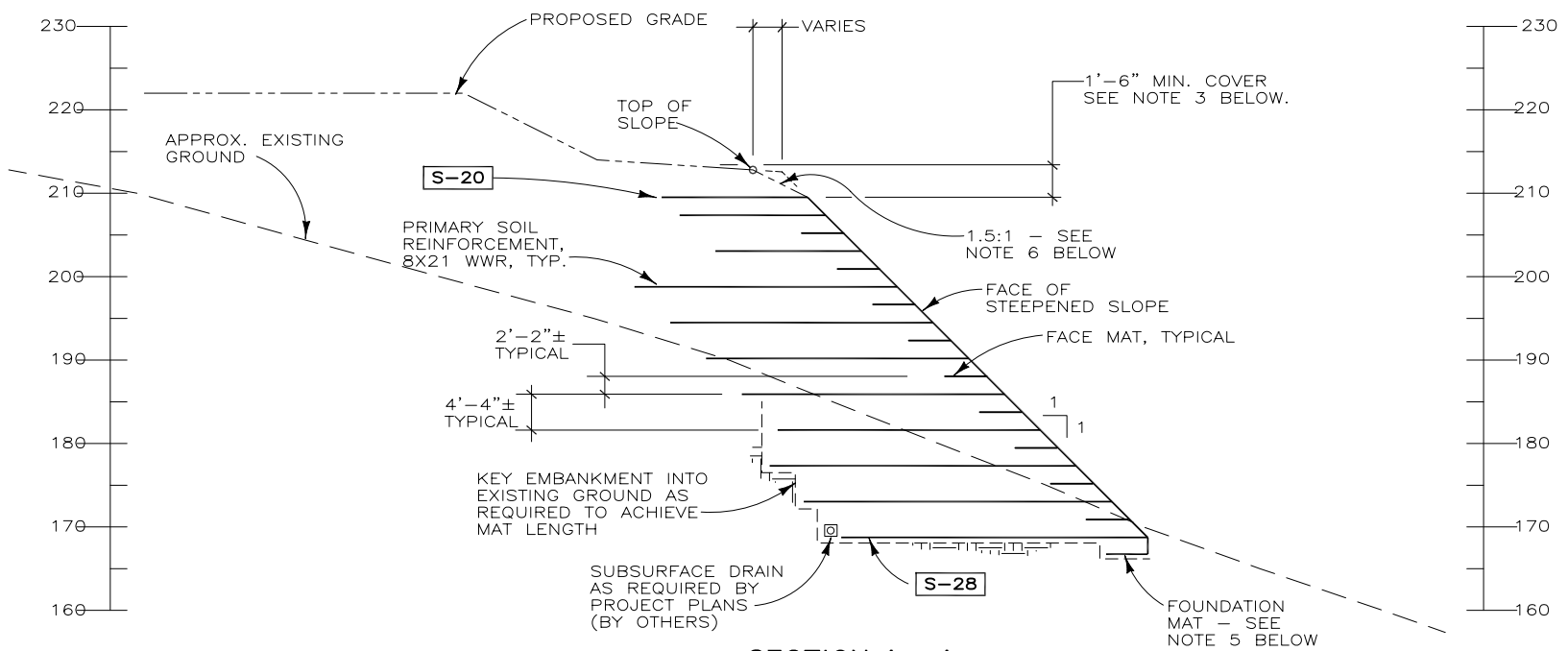

SECTION A - A

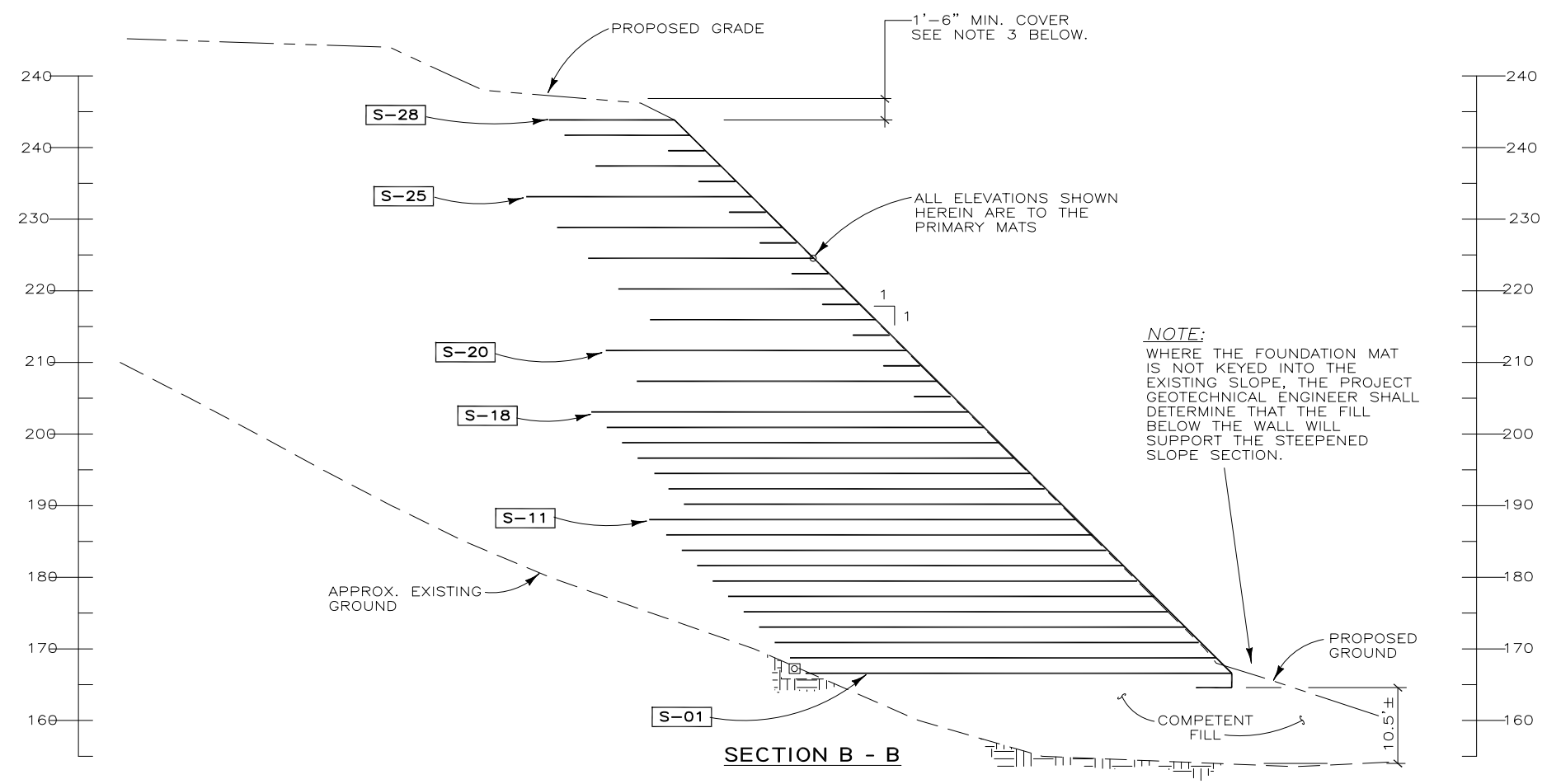

SECTION B - B

NOTES:

1. LIFTS NUMBERED 1 THRU 18 ARE SPACED 2.15' VERTICALLY
2. LIFTS NUMBERED 19 THRU 28 ARE SPACED 4.92' VERTICALLY UNLESS NOTED OTHERWISE.
3. IF COVER OVER TOP PRIMARY MAT IS LESS THAN 1'-6" DEFLECT THE PRIMARY MAT DOWNWARD VERTICALLY TO ACHIEVE MINIMUM COVER.
4. NOT ALL LIFTS IN ALL AREAS CONTAIN PRIMARY MATS. SOME LIFTS CONTAIN ONLY FACE MATS. ONLY THOSE AREAS CONTAINING PRIMARY MATS ARE DETAILED IN THE LIFT DRAWINGS HEREIN.
5. ELEVATIONS TO THE BOTTOM OF THE FOUNDATION MATS ARE NOT SHOWN. THEY CAN BE DETERMINED FROM THE ELEVATION SHOWN FOR THE PRIMARY MAT ABOVE THE FOUNDATION MAT.
6. THE TOP OF THE STEEPENED SLOPE (AND TOP PRIMARY MAT) COULD NOT BE SET AT THE GRADE BREAK LINE SHOWN ON THE ORIGINAL PROJECT PLANS BECAUSE OF THE FLAT AREA IMMEDIATELY BEHIND THE GRADE BREAK LINE. A MINIMUM OF 1'-6" COVER IS REQUIRED OVER THE TOP PRIMARY MAT; THEREFORE, THE TOP OF THE STEEPENED SLOPE HAD TO BE LOWERED TO ACHIEVE THE MINIMUM COVER.

NOTE:  
WHERE THE FOUNDATION MAT IS NOT KEYED INTO THE EXISTING SLOPE, THE PROJECT GEOTECHNICAL ENGINEER SHALL DETERMINE THAT THE FILL BELOW THE WALL WILL SUPPORT THE STEEPENED SLOPE SECTION.

050329AS PANORAMA WALL S

THIS DRAWING IS FURNISHED SOLELY FOR THE USE OF OR IN CONNECTION WITH THIS PROJECT, AND THE PROPRIETARY INFORMATION SHOWN HEREON IS NOT TO BE TRANSMITTED TO ANY OTHER ORGANIZATION WITHOUT SPECIFIC AUTHORIZATION BY THE HILFIKER COMPANY. HILFIKER RETAINING WALLS ARE PROTECTED BY ONE OR MORE OF THE FOLLOWING PATENTS: 3,631,682, 4,117,686, 4,260,296, 4,329,089, 4,324,508, 4,343,572, 4,391,557, 4,505,621, 4,616,959, 4,643,618, 4,661,023, 4,856,939, 5,733,072 AND OTHERS PENDING.

REV. NO.	DATE	BY	DESCRIPTION
1	08/11/05	DR	MINOR REVISIONS, ADDITIONS

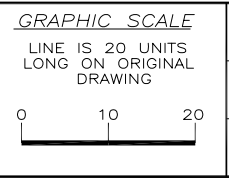

PROJ. MGR.  
WBH  
ENGINEER  
CADD BY  
DR

**HILFIKER RETAINING WALLS**  
3900 Broadway Eureka, CA 95503  
P.O. Box 2012 Eureka, CA 95501  
707-443-5093 Fax 707-443-2891  
Toll-Free 800-762-8962  
Web: <http://hilfiker.com> email: [info@hilfiker.com](mailto:info@hilfiker.com)



DWG DATE  
1 AUG 05  
REVISION DATE  
11 AUG 05  
SCALE  
NOTED

**SHOP DRAWING**  
STEEPENED SLOPE  
**PANORAMA WEST SUBDIVISION**  
WALL S  
PIERCE COUNTY, WASHINGTON  
SECTIONS A-A AND B-B

PROJECT NO.  
050329AS  
SHEET  
**2**  
OF 45

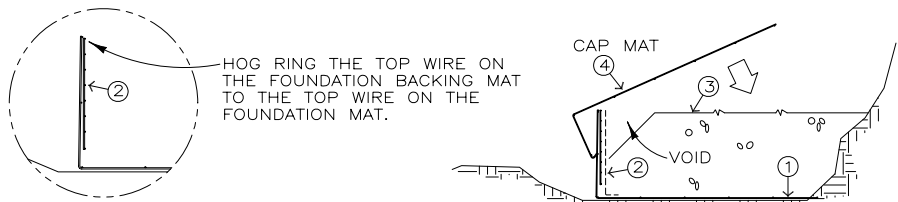

- A1. PREPARE THE FOUNDATION AND PLACE THE FOUNDATION MAT.
2. INSTALL THE FOUNDATION BACKING MAT AND FILTER FABRIC.
3. PLACE AND COMPACT BACKFILL TO 24" DEPTH AS SHOWN.
4. HOOK CAP MAT ON TRANSVERSE WIRE OF FOUNDATION MAT AND LAY IT DOWN ONTO THE BACKFILL.

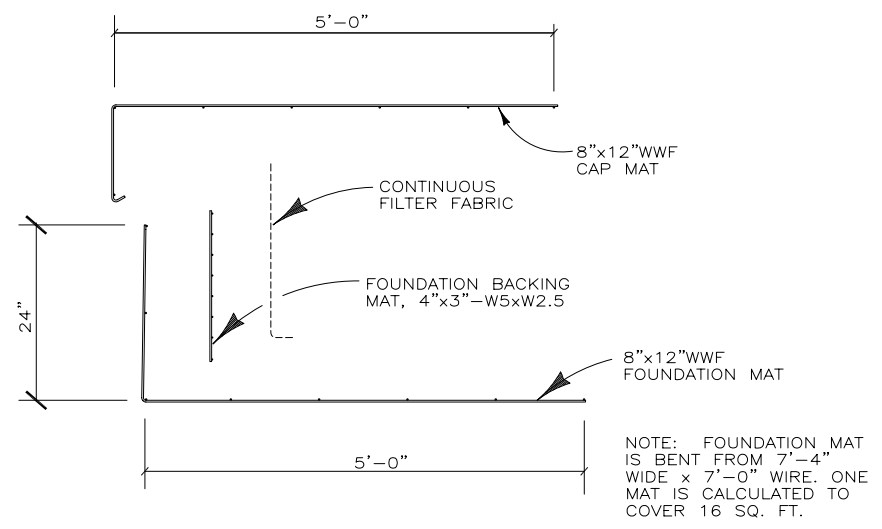

**FOUNDATION MAT AND CAP**  
SCALE: 10 X GRAPHIC SCALE

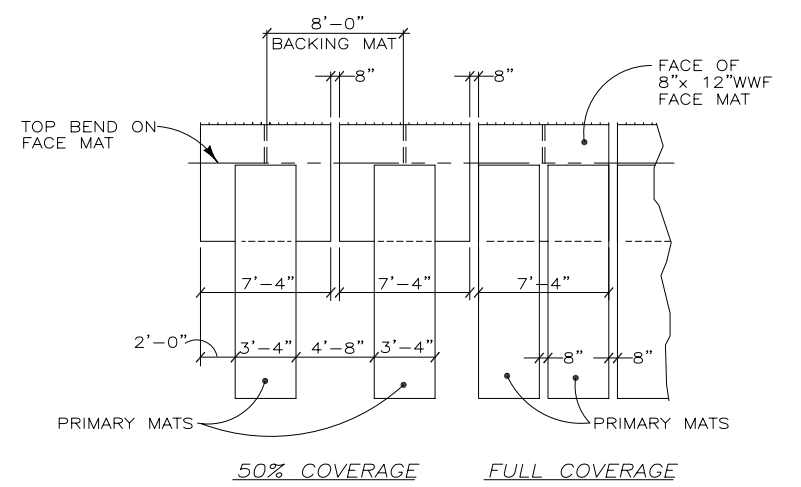

**PLAN VIEW**  
**ASSEMBLED MATS**  
NOT TO SCALE

- B1. FILL THE VOID BELOW THE FRONT OF THE CAP AND ROD TO FULLY COMPACT.
2. PLACE FIRST PRIMARY MAT ON FOUNDATION CAP MAT.
3. PLACE BACKFILL AND COMPACT TO 25.75" DEPTH.
4. PLACE BACKING MAT AND EROSION MAT OR SOD.
5. HOOK FACE MAT ON TRANSVERSE WIRES OF PRIMARY MAT AND THE FOUNDATION MAT AND LAY IT DOWN ONTO THE BACKFILL

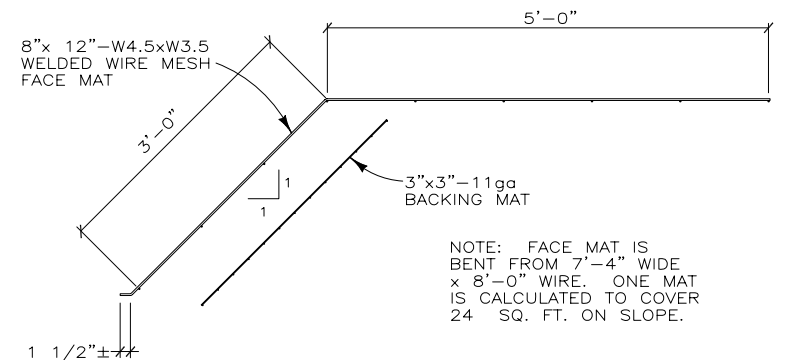
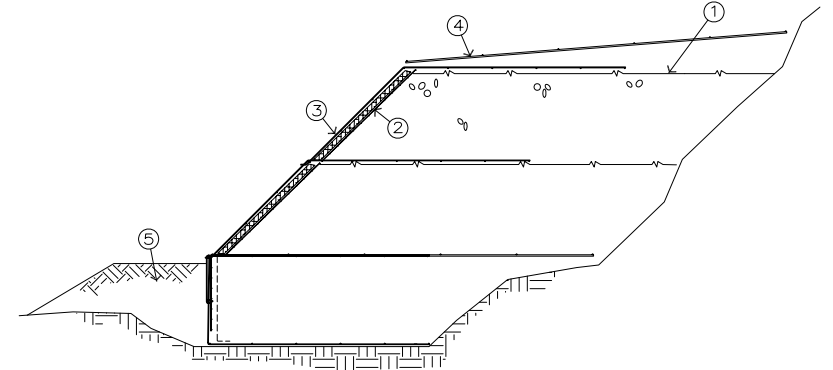

**FACE MAT DETAIL**  
SCALE: 10 X GRAPHIC SCALE

- C1. PLACE AND COMPACT SECOND 25.75" LIFT OF BACKFILL.
2. PLACE BACKING MAT AND EROSION MAT OR SOD.
3. ROTATE AND INSTALL FACE MAT AS IN STEP 4 ABOVE.
4. PLACE PRIMARY MAT WITH TRANSVERSE WIRE ALIGNED WITH THE TRANSVERSE WIRE OF THE LOWER FACE MAT THAT WILL BE HOOKED WITH THE NEXT FACE MAT.
5. BACKFILL AND COMPACT SOIL AT TOE OF WALL.

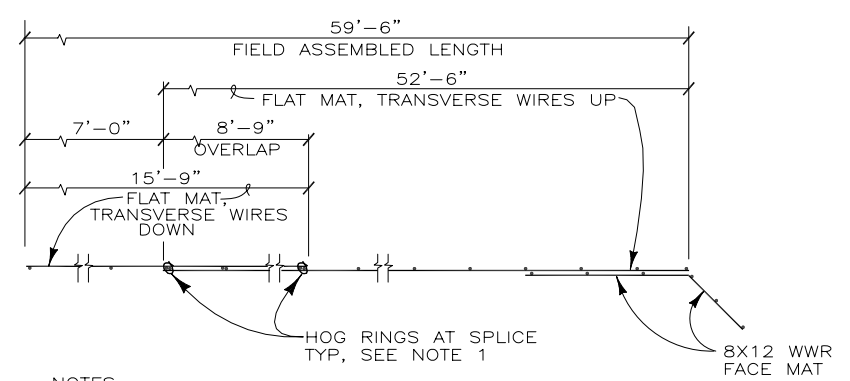

- NOTES**
1. INSTALL HOG RINGS AT 4 PLACES, BOTH FRONT AND BACK OF OVERLAP.
  2. FLAT MAT WIRE DIAMETERS SHALL MATCH. SEE WALL DRAWINGS AND TYPICAL SECTION.

**59'-6" FLAT MAT SPLICE DETAIL**  
NO SCALE

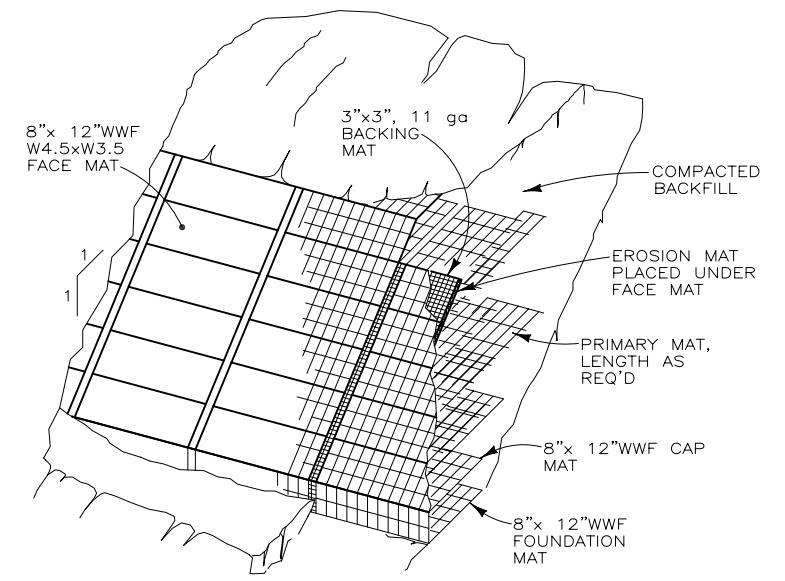

**PICTORIAL ELEVATION**  
NOT TO SCALE

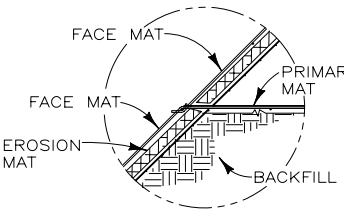

- D1. PLACE THE NEXT LIFT OF BACKFILL, BACKING MAT AND EROSION MAT OR SOD.
2. INSTALL THE FACE MAT SO IT ENGAGES BOTH THE PRIMARY MAT AND THE LOWER FACE MAT
3. CONTINUE LIFTS TO THE TOP OF THE WALL.
4. AFTER PLACING THE TOP LIFT OF BACKFILL AND FACE MAT, BACKING MAT AND EROSION MAT, PLACE THE PRIMARY MAT AND HOOK IT TO THE FACE MAT WITH HOG RINGS. BACKFILL AND COMPACT THE REQUIRED COVER OVER THE PRIMARY MAT.

**CONSTRUCTION SEQUENCE**  
NOT TO SCALE

050329AS PANORAMA WALL S

THIS DRAWING IS FURNISHED SOLELY FOR THE USE OF OR IN CONNECTION WITH THIS PROJECT, AND THE PROPRIETARY INFORMATION SHOWN HEREON IS NOT TO BE TRANSMITTED TO ANY OTHER ORGANIZATION WITHOUT SPECIFIC AUTHORIZATION BY THE HILFIKER COMPANY. HILFIKER RETAINING WALLS ARE PROTECTED BY ONE OR MORE OF THE FOLLOWING PATENTS: 3,631,682, 4,117,686, 4,260,296, 4,329,089, 4,324,808, 4,343,572, 4,391,557, 4,505,621, 4,616,959, 4,643,618, 4,661,023, 4,856,939, 5,733,072 AND OTHERS PENDING.	REV. NO.	DATE	BY	DESCRIPTION	<b>GRAPHIC SCALE</b> LINE IS 20 UNITS LONG ON ORIGINAL DRAWING 	PROJ. MGR.	<b>HILFIKER RETAINING WALLS</b> 3900 Broadway Eureka, CA 95503 P.O. Box 2012 Eureka, CA 95501 707-443-5093 Fax 707-443-2891 Toll-Free 800-762-8962 Web: <a href="http://hilfiker.com">http://hilfiker.com</a> email: <a href="mailto:info@hilfiker.com">info@hilfiker.com</a>	DWG DATE	<b>SHOP DRAWING</b> STEEPENED SLOPE <b>PANORAMA WEST SUBDIVISION</b> WALL S PIERCE COUNTY, WASHINGTON TYPICAL DETAILS	PROJECT NO.
	1	08/11/05	DR	ADDED SPLICE DETAIL		ENGINEER		11 AUG 05		050329AS
						CADD BY	REVISION DATE		SHEET	
						DR	11 AUG 05		<b>3</b>	
							SCALE		OF 45	
							NOTED			



CAD: 005002-090-WALL-A-1-JUNE-REV  
(HRW 050329AS & AN)

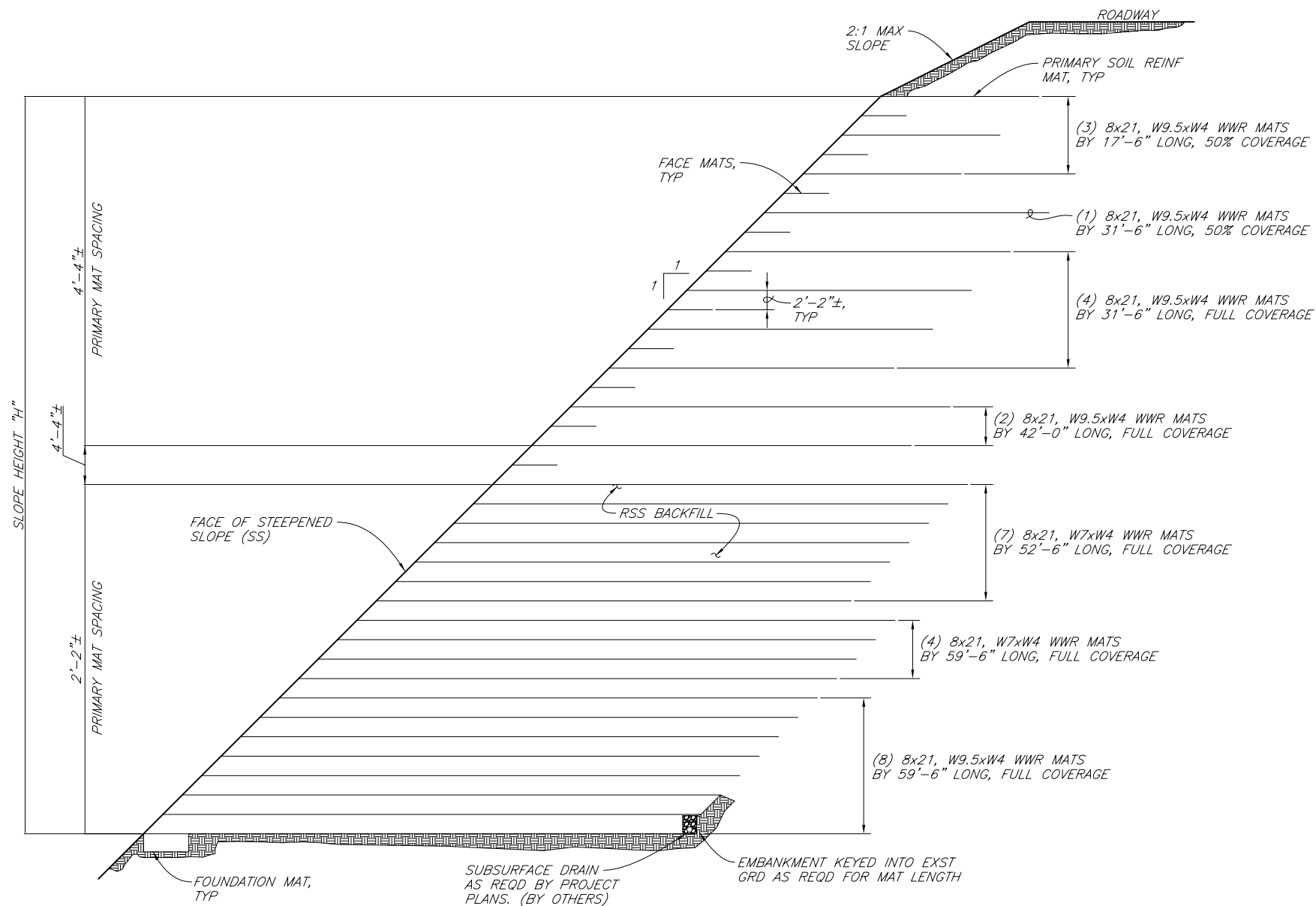

SECTION: 70'-10" < H ≤ 81'-6"  
NO SCALE

**NOTE:** FOR SLOPE HEIGHTS LESS THAN THE MAXIMUM HEIGHTS SHOWN DELETE LOWER WWR MATS AS REQUIRED. HOWEVER, AT LEAST (2) OF THE LONGEST (LOWER MOST) MATS MUST BE USED (DELETE THE THIRD MAT UP).

**DESIGN NOTES**

- DESIGN IS BASED ON THE ASSUMPTION THAT BACKFILL WITHIN THE REINFORCED SOIL MASS, METHODS OF CONSTRUCTION AND QUALITY OF MATERIALS CONFORM TO THE REQUIREMENTS OF HILFIKER RETAINING WALLS.
- ASSUMED SOIL CHARACTERISTICS:  
WALL BACKFILL:  
UNIT WEIGHT: 125 PCF  
INTERNAL FRICTION ANGLE: 38°  
COHESION: 0 PSF  
RANDOM BACKFILL:  
UNIT WEIGHT: 125 PCF  
INTERNAL FRICTION ANGLE: 38°  
COHESION = 0 PSF  
FOUNDATION SOILS:  
UNIT WEIGHT: 128 PCF  
FRICTION ANGLE FOR SLIDING: 38°  
COHESION = 100 PSF  
LIVE LOAD SURCHARGE = 250 PSF  
IF ACTUAL CHARACTERISTICS, GRADES OR DIMENSIONS OF SOIL MATERIALS DIFFER FROM THOSE LISTED ABOVE OR SHOWN ON THE PLANS HILFIKER RETAINING WALLS SHALL BE NOTIFIED TO EVALUATE THE NEED TO REDESIGN.
- THE DESIGN REQUIRES A NON-SATURATED BACKFILL. SURFACE AND SUB-SURFACE DRAINAGE CONTROL MAY BE REQUIRED TO PREVENT SATURATION OF THE BACKFILL OR RELIEVE HYDROSTATIC PRESSURES.  
DRAINAGE CONTROL SHALL BE AS SPECIFIED IN THE PROJECT PLANS AND SPECIFICATIONS OR AS DIRECTED BY THE ENGINEER.
- DESIGN PROCEDURE:  
RSS REINFORCED SLOPE STABILITY, FHWA REPORT NO. FHWA-SA-96-039.
- REFERENCE DRAWINGS:  
11x17 REDUCED DRAWINGS OF SHEETS ESC11 THRU ESC25, DATED 1/18/2005 AND R1 THRU R35, DATED 1/17/2005, PREPARED BY LEROY, SURVEYORS AND ENGINEERS. IN ADDITION, AUTOCAD ELECTRONIC FILES OF THE FOLLOWING WERE PROVIDED BY OLSON BROS.: panorama west design surfaces dtm 051305.dwg and PW design contours may 03 05.dwg.

NOTE:  
THIS DRAWING CREATED BY SHN ENGINEERS FOR USE IN THIS PROJECT, AND INCLUDED FOR DESIGN INFORMATION.

THE DESIGN CONTAINED ON THESE DRAWINGS IS BASED ON INFORMATION PROVIDED BY THE OWNER. ON THE BASIS OF THIS INFORMATION, THE HILFIKER COMPANY HAS DESIGNED, AND IS RESPONSIBLE FOR THE INTERNAL STABILITY OF THE STRUCTURE ONLY. EXTERNAL STABILITY, INCLUDING FOUNDATION AND SLOPE STABILITY, IS THE RESPONSIBILITY OF THE OWNER.



STEEPENED SLOPE (SS)  
**HILFIKER RETAINING WALLS**  
P.O. BOX 2012 EUREKA, CALIFORNIA 95502-2012  
PHONE: (707) 443-5093 FAX: (707) 443-2891

SHEET  
**4**  
OF 45

DATE 7/15/05  
PROJ. NO. 005002.090

VERIFY SCALES  
BAR IS ONE INCH ON ORIGINAL DRAWING  
IF NOT ONE INCH ON THIS SHEET, ADJUST SCALES ACCORDINGLY

CONSULTING ENGINEERS & GEOLOGISTS, INC.  
812 W. Webster  
Eureka, CA 95501  
(707) 441-8855  
FAX (707) 441-8877

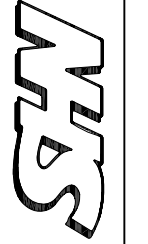

NO.	DATE	REVISION	BY

DSGN K/JV  
OR CDV  
CHK K/JV  
APVD

PANORAMA WEST SUBDIVISION  
RHODES LAKE ROAD, BONNEY LAKE  
PIERCE COUNTY WASHINGTON  
**TYPICAL SECTION AND NOTES**

SHEET 1 OF 4  
DATE 7/15/05  
PROJ. NO. 005002.090

CAD: 005002-090-WALL-A-1-JUNE-REV  
(HRW 050329AS & AN)

THE DESIGN CONTAINED ON THESE DRAWINGS IS BASED ON INFORMATION PROVIDED BY THE OWNER. ON THE BASIS OF THIS INFORMATION, THE HILFIKER COMPANY HAS DESIGNED, AND IS RESPONSIBLE FOR THE INTERNAL STABILITY OF THE STRUCTURE ONLY. EXTERNAL STABILITY, INCLUDING FOUNDATION AND SLOPE STABILITY, IS THE RESPONSIBILITY OF THE OWNER.

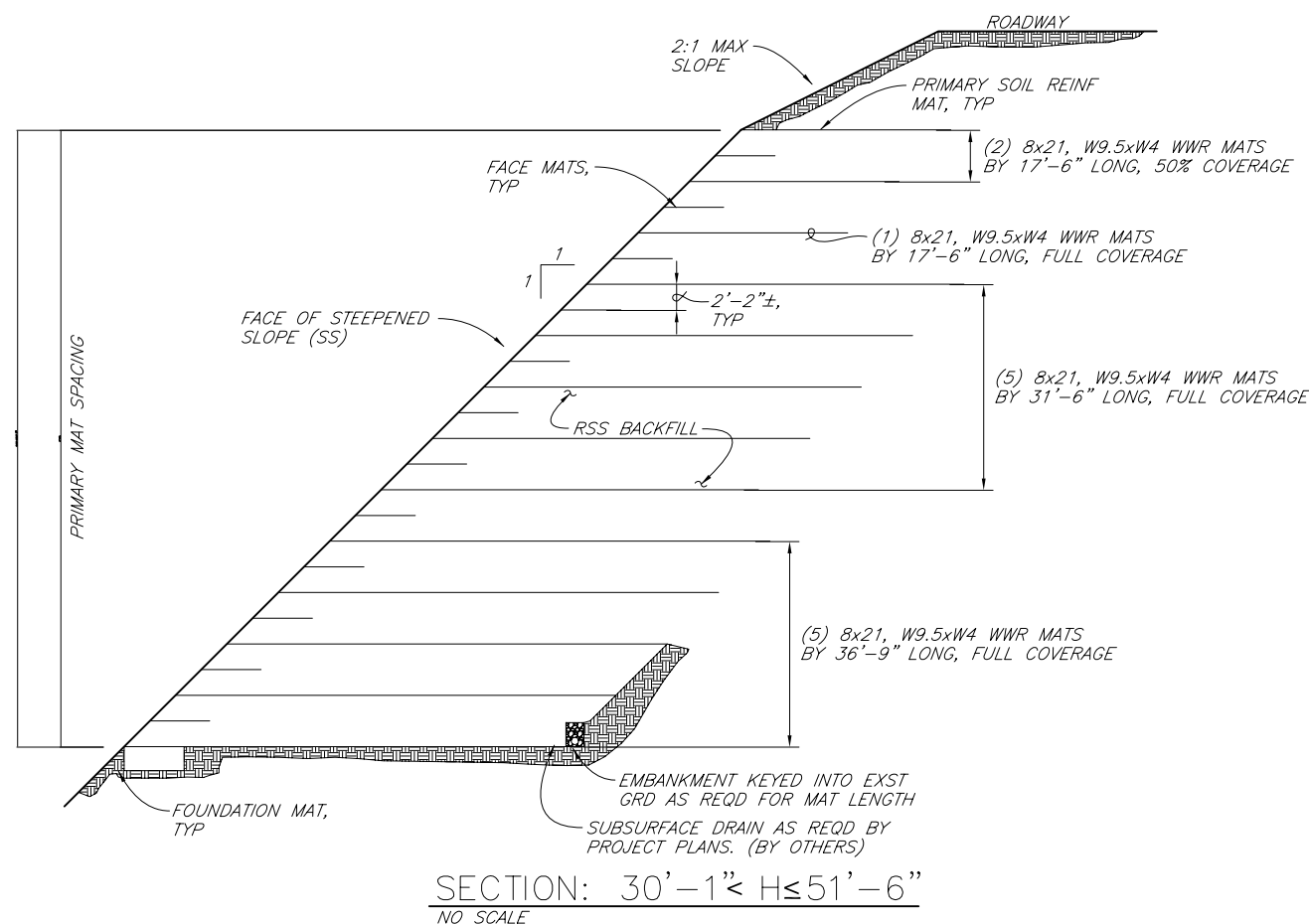
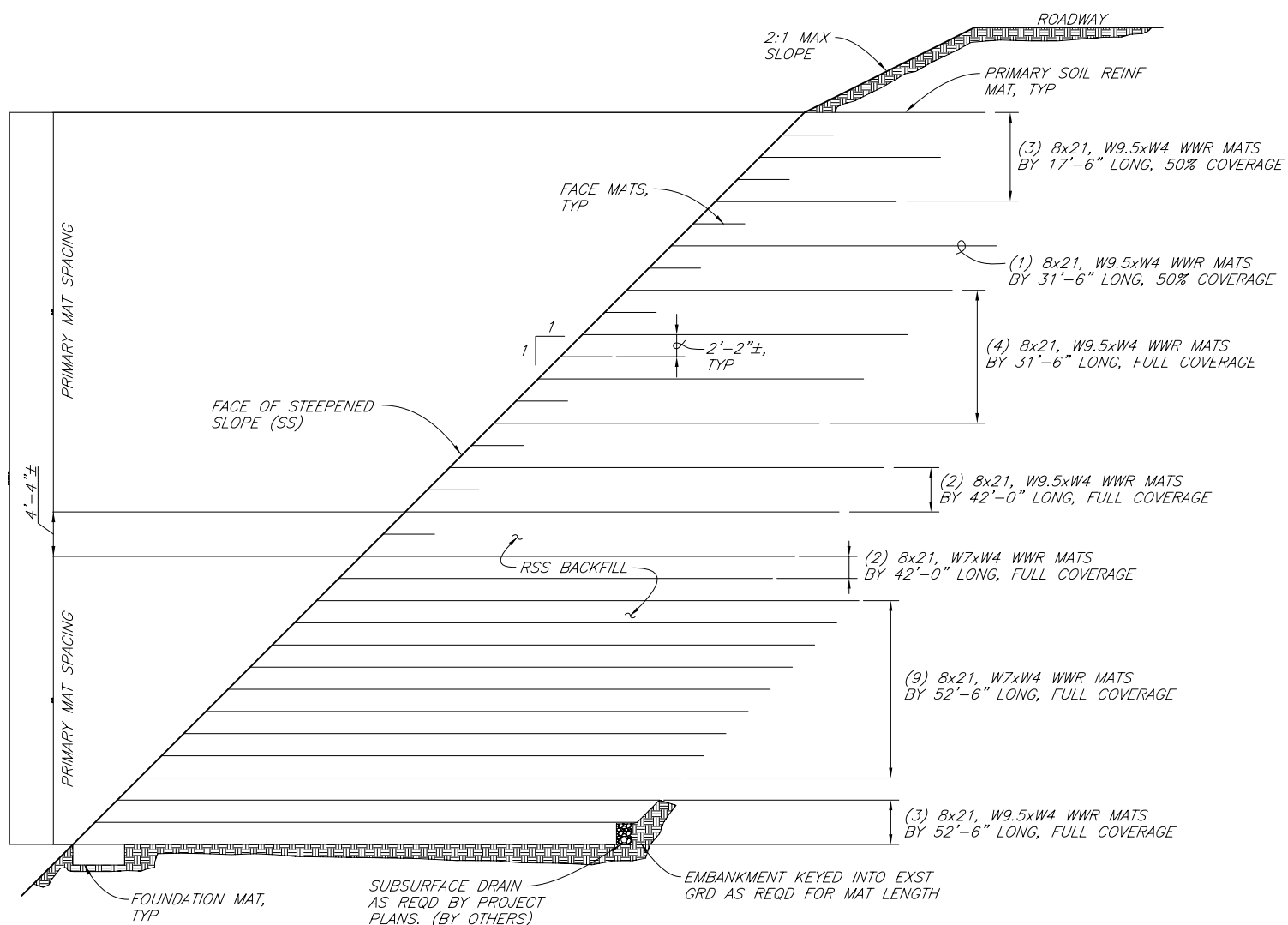

NOTE:  
THIS DRAWING CREATED BY SHN ENGINEERS FOR USE IN THIS PROJECT, AND INCLUDED FOR DESIGN INFORMATION.



STEEPENED SLOPE (SS)  
**HILFIKER RETAINING WALLS**  
P.O. BOX 2012 EUREKA, CALIFORNIA 95502-2012  
PHONE: (707) 443-5093 FAX: (707) 443-2891

SHEET  
**5**  
OF 45

SHEET  
2 OF 4  
DATE 7/15/05  
PROJ. NO.  
005002.090

VERIFY SCALES  
BAR IS ONE INCH ON ORIGINAL DRAWING  
IF NOT ONE INCH ON THIS SHEET ADJUST SCALES ACCORDINGLY

CONSULTING ENGINEERS & GEOLOGISTS, INC.  
812 W. Wabash  
Eureka, CA 95501  
(707) 441-8855  
FAX (707) 441-8877

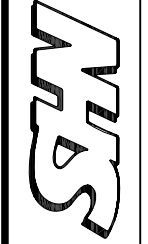

NO.	DATE	REVISION	BY

DSGN  
K/JV  
DR C/DV  
CHK K/JV  
APVD

PANORAMA WEST SUBDIVISION  
RHODES LAKE ROAD, BONNEY LAKE  
PIERCE COUNTY WASHINGTON  
**TYPICAL SECTIONS**

CAD: 005002-090-WALL-A-1-JUNE-REV  
(HRW 050329AS & AV)

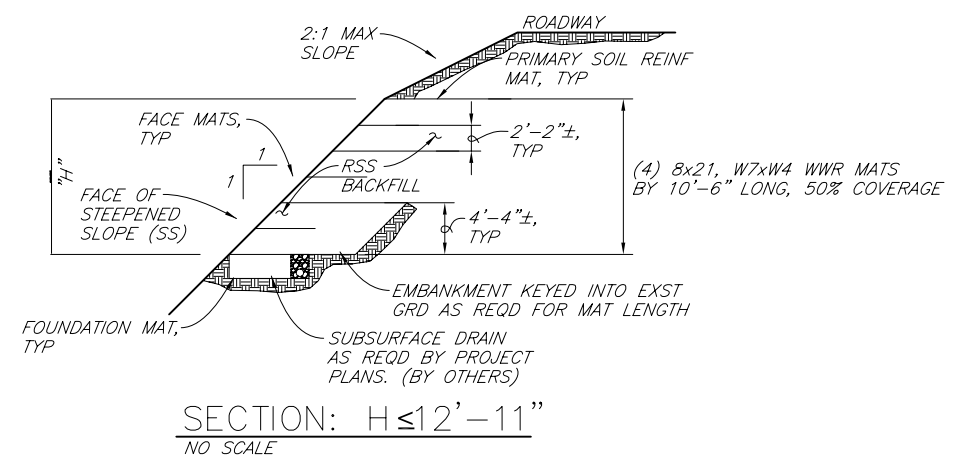
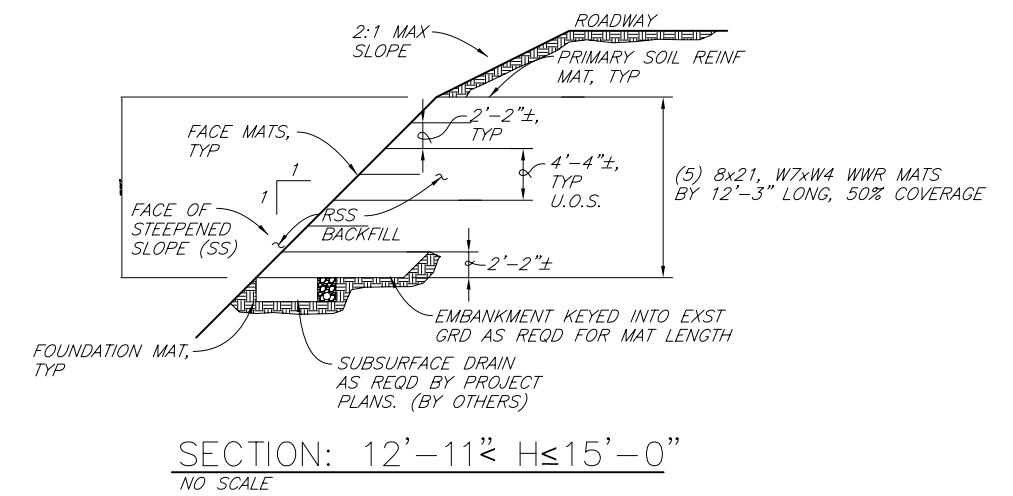
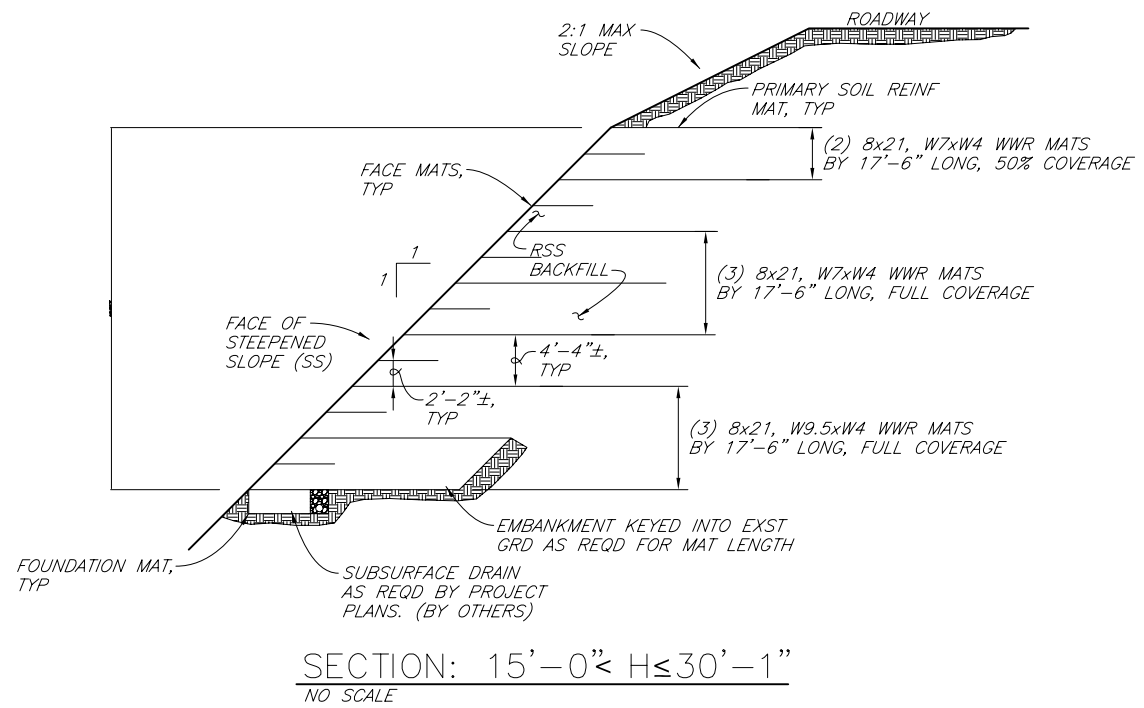

NOTE:  
THIS DRAWING CREATED  
BY SHN ENGINEERS FOR  
USE IN THIS PROJECT,  
AND INCLUDED FOR  
DESIGN INFORMATION.

THE DESIGN CONTAINED ON THESE DRAWINGS IS BASED ON INFORMATION PROVIDED BY THE OWNER. ON THE BASIS OF THIS INFORMATION, THE HILFIKER COMPANY HAS DESIGNED, AND IS RESPONSIBLE FOR THE INTERNAL STABILITY OF THE STRUCTURE ONLY. EXTERNAL STABILITY, INCLUDING FOUNDATION AND SLOPE STABILITY, IS THE RESPONSIBILITY OF THE OWNER.



STEEPENED SLOPE (SS)  
**HILFIKER RETAINING WALLS**  
P.O. BOX 2012 EUREKA, CALIFORNIA 95502-2012  
PHONE: (707) 443-5093 FAX: (707) 443-2891

SHEET  
**6**  
OF 45

SHEET  
3 OF 4  
DATE 7/15/05  
PROJ. NO.  
005002.090

VERIFY SCALES  
BAR IS ONE INCH ON ORIGINAL DRAWING  
IF NOT ONE INCH ON THIS SHEET, ADJUST SCALES ACCORDINGLY

CONSULTING ENGINEERS & GEOLOGISTS, INC.  
812 W. Webster  
Eureka, CA 95501 FAX (707) 441-8877



NO.	DATE	REVISION	BY

DSGN: K/JV  
DR: C/JV  
CHK: K/JV  
APPV: APV

PANORAMA WEST SUBDIVISION  
RHODES LAKE ROAD, BONNEY LAKE  
PIERCE COUNTY WASHINGTON

TYPICAL SECTIONS

116th AVE. E.  
STA. 301+32.61  
198.29' LT.

116th AVE. E.  
STA. 301+41.89  
193.90' LT.

116th AVE. E.  
STA. 301+81.46  
192.29' LT.

FACE OF PRIMARY MAT  
AND FOUNDATION MAT

116th AVE. E.  
STA. 301+70.66  
190.33' LT.

FOUNDATION  
MAT BELOW, TYPICAL

16 - 8x21, W9.5xW4.0  
WWR PRIMARY MATS,  
59'-6" LONG

LINE S-01  
ELEVATION 166.59

FROM END OF 116th  
AVE. E. CENTERLINE  
STA. 286+39.87  
N 10°49'06"E  
188.66'

FROM END OF 116th  
AVE. E. CENTERLINE  
STA. 286+39.87  
N 18°04'59"E  
189.76'

116th AVE. E.  
STA. 286+33.66  
189.63' RT.

116th AVE. E.  
STA. 286+30.15  
189.34' RT.

FACE OF PRIMARY MAT  
AND FOUNDATION MAT

116th AVE. E.  
STA. 286+16.32  
186.62' RT.

FOUNDATION  
MAT BELOW, TYPICAL

LINE S-02  
ELEVATION 168.74

116th AVE. E.  
STA. 283+30.30  
187.85 RT.

W. HILL DR. E./  
171st AVE. E.  
STA. 301+41.69  
191.78' LT.

W. HILL DR. E./  
171st AVE. E.  
STA. 301+56.32  
190.16' LT.

2 - 8x21, W9.5xW4.0  
WWR PRIMARY MATS,  
52'-6" LONG

W. HILL DR. E./  
171st AVE. E.  
STA. 301+75.50  
187.82' LT.

FOUNDATION  
MAT BELOW, TYPICAL

2 - 8x21, W9.5xW4.0  
WWR PRIMARY MATS,  
52'-6" LONG

20 - 8x21, W9.5xW4.0  
WWR PRIMARY MATS,  
59'-6" LONG

LINE S-02  
ELEVATION 168.74

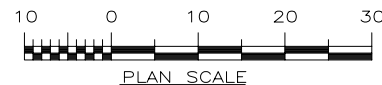

**NOTE:**  
ONLY MAJOR POINTS ALONG  
THE WALL LINES HAVE BEEN  
LOCATED.

050329AS PANORAMA WALL S

THIS DRAWING IS FURNISHED SOLELY FOR THE USE OF OR IN CONNECTION WITH THIS PROJECT, AND THE PROPRIETARY INFORMATION SHOWN HEREON IS NOT TO BE TRANSMITTED TO ANY OTHER ORGANIZATION WITHOUT SPECIFIC AUTHORIZATION BY THE HILFIKER COMPANY. HILFIKER RETAINING WALLS ARE PROTECTED BY ONE OR MORE OF THE FOLLOWING PATENTS: 3,631,682, 4,117,686, 4,260,296, 4,329,089, 4,324,808, 4,343,572, 4,391,557, 4,505,621, 4,616,959, 4,643,618, 4,661,023, 4,856,939, 5,733,072 AND OTHERS PENDING.

REV. NO.	DATE	BY	DESCRIPTION
1	08/11/05	DR	MINOR REVISIONS, ADDITIONS

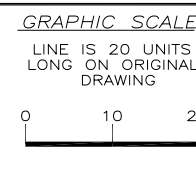

PROJ. MGR.  
WBH  
ENGINEER  
CADD BY  
DR

**HILFIKER RETAINING WALLS**  
3900 Broadway Eureka, CA 95503  
P.O. Box 2012 Eureka, CA 95501  
707-443-5093 Fax 707-443-2891  
Toll-Free 800-762-8962  
Web: <http://hilfiker.com> email: [info@hilfiker.com](mailto:info@hilfiker.com)



DWG DATE  
1 AUG 05  
REVISION DATE  
11 AUG 05  
SCALE  
NOTED

**SHOP DRAWING**  
STEEPENED SLOPE  
**PANORAMA WEST SUBDIVISION**  
WALL S  
PIERCE COUNTY, WASHINGTON  
LINE S-01 AND S-02

PROJECT NO.  
050329AS  
SHEET  
**7**  
OF 45

W. HILL DR. E./  
171st AVE. E.  
STA. 307+09  
164.96' LT.

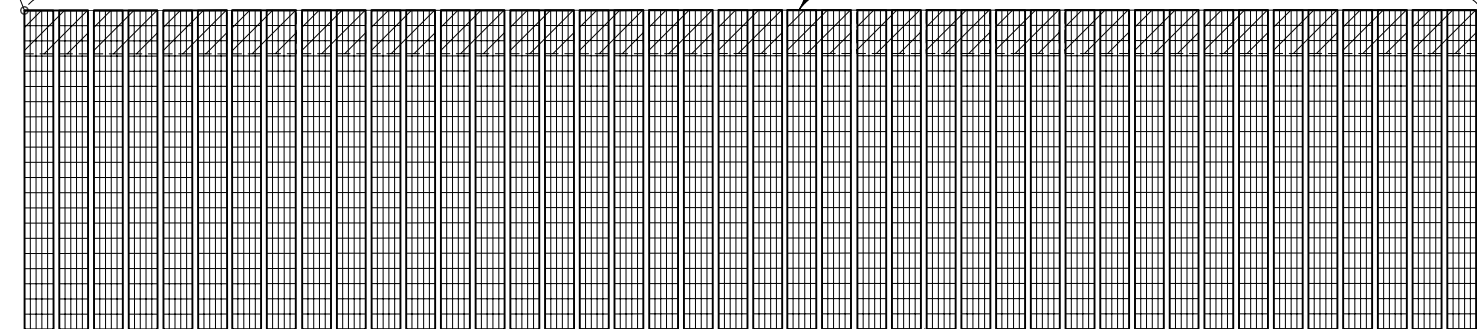

42 - 8x21, W9.5xW4.0  
WWR PRIMARY MATS,  
36'-9" LONG

LINE S-02  
ELEVATION 168.74

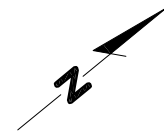

W. HILL DR. E./  
171st AVE. E.  
STA. 310+04.87  
137.71' LT.

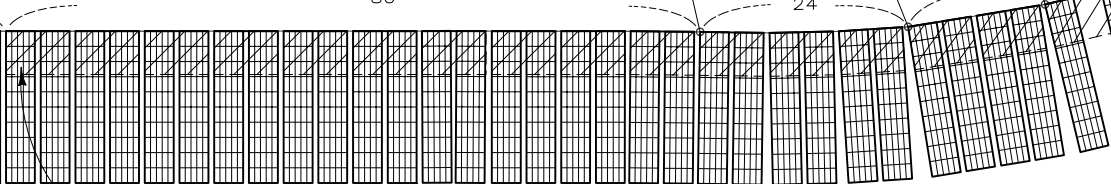

FOUNDATION  
MAT BELOW, TYPICAL

31 - 8x21, W9.5xW4.0  
WWR PRIMARY MATS,  
17'-6" LONG

1 - 8x21, W7.0xW4.0  
WWR PRIMARY MATS,  
12'-3" LONG

3 - 8x21, W7.0xW4.0  
WWR PRIMARY MATS,  
10'-6" LONG

W. HILL DR. E./  
171st AVE. E.  
STA. 310+26.71  
135.37' LT.

W. HILL DR. E./  
171st AVE. E.  
STA. 310+46.88  
134.12' LT.

FACE OF PRIMARY MAT  
AND FOUNDATION MAT

FROM END OF 116th  
AVE. E. CENTERLINE  
STA. 286+39.87  
N 05°54'43"E  
187.48'

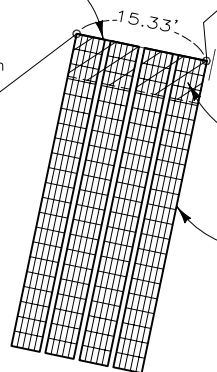

4 - 8x21, W9.5xW4.0  
WWR PRIMARY MATS,  
36'-9" LONG

LINE S-03  
ELEVATION 170.89



FACE OF PRIMARY MAT  
AND FOUNDATION MAT

W. HILL DR. E./  
171st AVE. E.  
STA. 306+85.24  
165.07 LT.

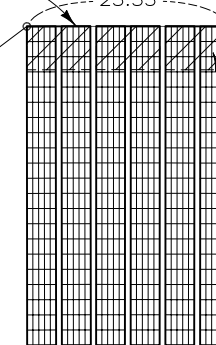

6 - 8x21, W9.5xW4.0  
WWR PRIMARY MATS,  
36'-9" LONG

LINE S-03  
ELEVATION 170.89

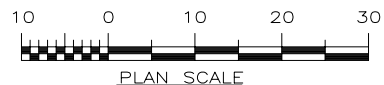
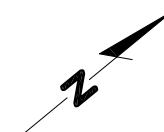

**NOTE:**

ONLY MAJOR POINTS ALONG  
THE WALL LINES HAVE BEEN  
LOCATED.

050329AS PANORAMA WALL S

THIS DRAWING IS FURNISHED SOLELY FOR THE USE OF OR IN CONNECTION WITH THIS PROJECT, AND THE PROPRIETARY INFORMATION SHOWN HEREON IS NOT TO BE TRANSMITTED TO ANY OTHER ORGANIZATION WITHOUT SPECIFIC AUTHORIZATION BY THE HILFIKER COMPANY. HILFIKER RETAINING WALLS ARE PROTECTED BY ONE OR MORE OF THE FOLLOWING PATENTS: 3,631,682, 4,117,686, 4,260,296, 4,329,089, 4,324,508, 4,343,572, 4,391,557, 4,505,621, 4,616,959, 4,643,618, 4,661,023, 4,856,939, 5,733,072 AND OTHERS PENDING.

REV. NO.	DATE	BY	DESCRIPTION
1	08/11/05	DR	MINOR REVISIONS, ADDITIONS

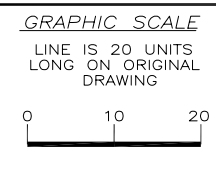

PROJ. MGR.  
WBH  
ENGINEER  
CADD BY  
DR

**HILFIKER RETAINING WALLS**  
3900 Broadway Eureka, CA 95503  
P.O. Box 2012 Eureka, CA 95501  
707-443-5093 Fax 707-443-2891  
Toll-Free 800-762-8962  
Web: <http://hilfiker.com> email: [info@hilfiker.com](mailto:info@hilfiker.com)



DWG DATE  
1 AUG 05  
REVISION DATE  
11 AUG 05  
SCALE  
NOTED

**SHOP DRAWING**  
STEEPENED SLOPE  
**PANORAMA WEST SUBDIVISION**  
WALL S  
PIERCE COUNTY, WASHINGTON  
LINE S-02 AND S-03

PROJECT NO.  
050329AS  
SHEET  
**8**  
OF 45



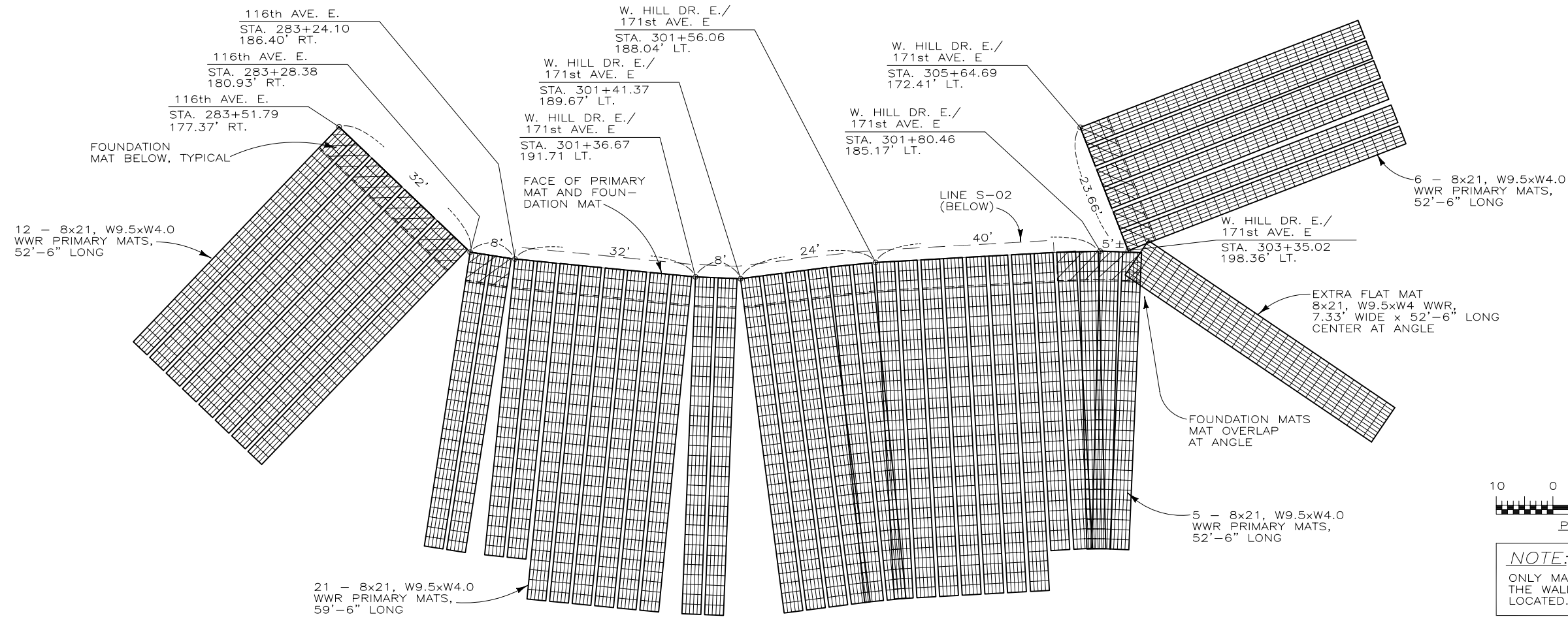

**LINE S-03**  
ELEVATION 170.89

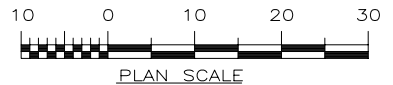

**NOTE:**  
ONLY MAJOR POINTS ALONG THE WALL LINES HAVE BEEN LOCATED.

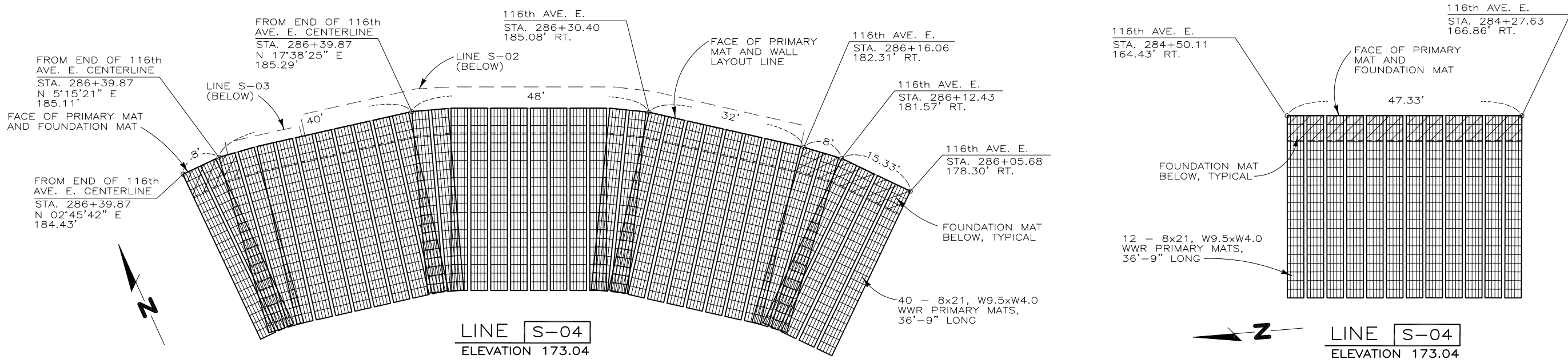

**LINE S-04**  
ELEVATION 173.04

**LINE S-04**  
ELEVATION 173.04

050329AS PANORAMA WALL S

THIS DRAWING IS FURNISHED SOLELY FOR THE USE OF OR IN CONNECTION WITH THIS PROJECT, AND THE PROPRIETARY INFORMATION SHOWN HEREON IS NOT TO BE TRANSMITTED TO ANY OTHER ORGANIZATION WITHOUT SPECIFIC AUTHORIZATION BY THE HILFIKER COMPANY. HILFIKER RETAINING WALLS ARE PROTECTED BY ONE OR MORE OF THE FOLLOWING PATENTS: 3,631,682, 4,117,686, 4,260,296, 4,329,089, 4,324,508, 4,343,572, 4,391,557, 4,505,621, 4,616,959, 4,643,618, 4,661,023, 4,856,939, 5,733,072 AND OTHERS PENDING.

REV. NO.	DATE	BY	DESCRIPTION
1	08/11/05	DR	MINOR REVISIONS, ADDITIONS

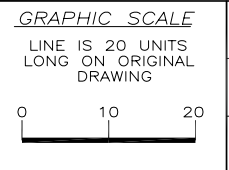

PROJ. MGR.  
WBH  
ENGINEER  
CADD BY  
DR

**HILFIKER RETAINING WALLS**  
3900 Broadway Eureka, CA 95503  
P.O. Box 2012 Eureka, CA 95501  
707-443-5093 Fax 707-443-2891  
Toll-Free 800-762-8962  
Web: <http://hilfiker.com> email: [info@hilfiker.com](mailto:info@hilfiker.com)



DWG DATE  
1 AUG 05  
REVISION DATE  
11 AUG 05  
SCALE  
NOTED

**SHOP DRAWING**  
STEEPENED SLOPE  
**PANORAMA WEST SUBDIVISION**  
WALL S  
PIERCE COUNTY, WASHINGTON  
LINE S-03 AND S-04

PROJECT NO.  
050329AS  
SHEET  
**9**  
OF 45

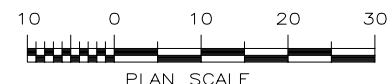
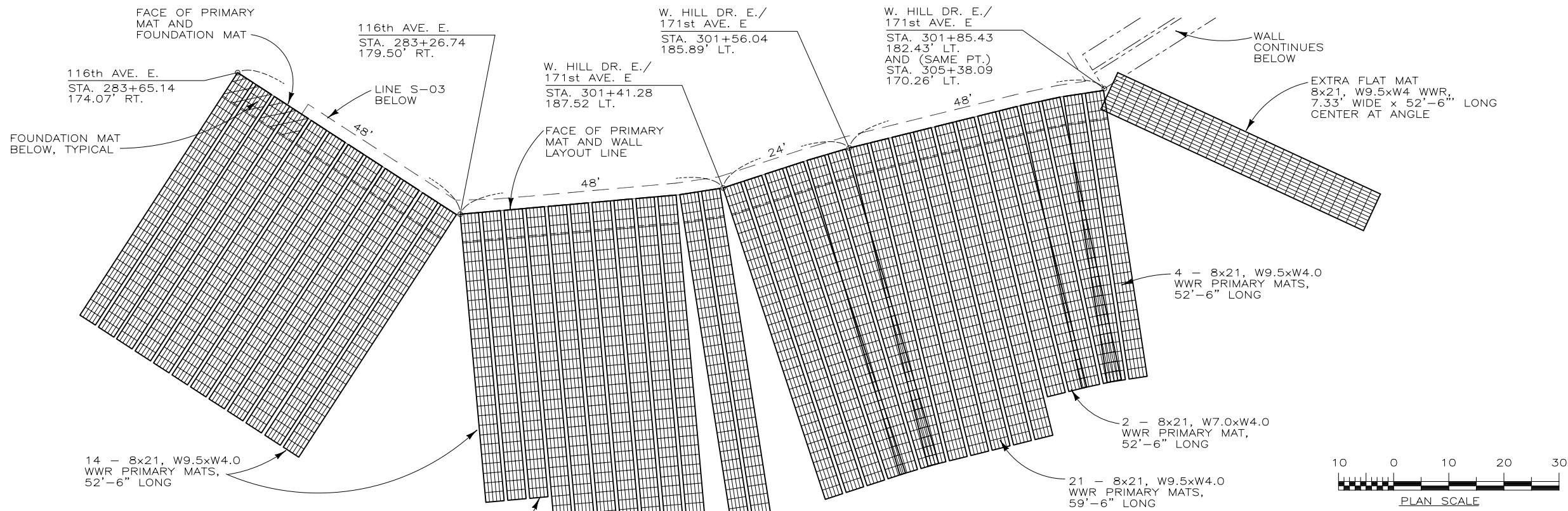

**NOTE:**  
ONLY MAJOR POINTS ALONG THE WALL LINES HAVE BEEN LOCATED.

**LINE S-04**  
ELEVATION 173.04

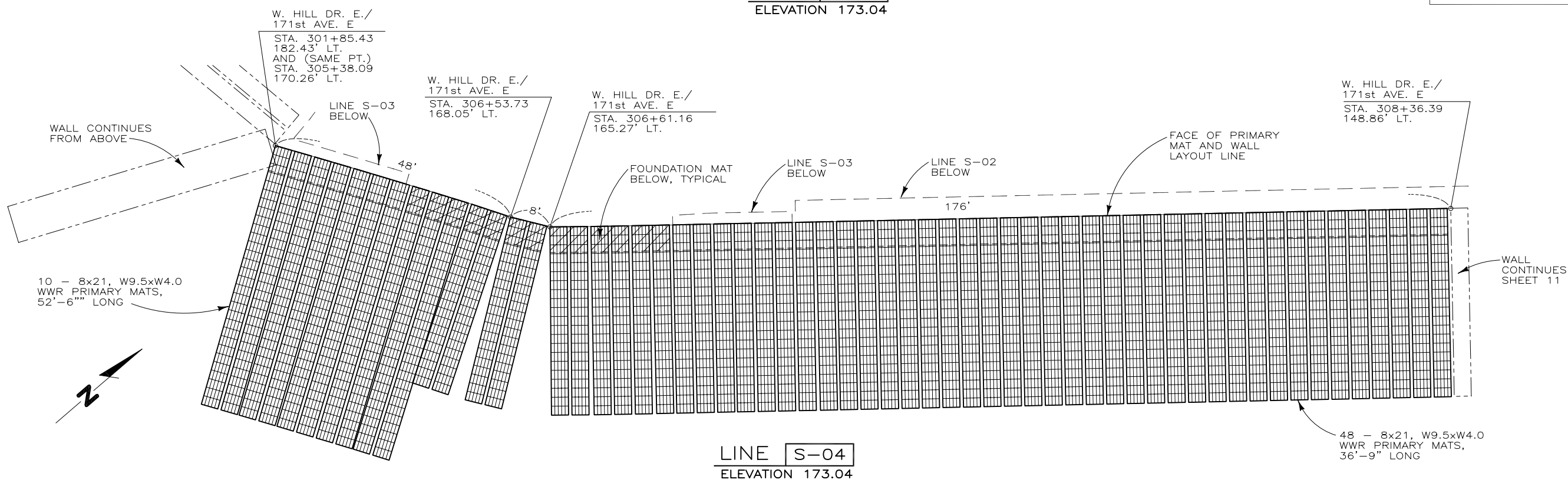

**LINE S-04**  
ELEVATION 173.04

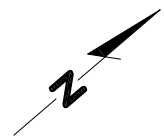

050329AS PANORAMA WALL S

THIS DRAWING IS FURNISHED SOLELY FOR THE USE OF OR IN CONNECTION WITH THIS PROJECT, AND THE PROPRIETARY INFORMATION SHOWN HEREON IS NOT TO BE TRANSMITTED TO ANY OTHER ORGANIZATION WITHOUT SPECIFIC AUTHORIZATION BY THE HILFIKER COMPANY. HILFIKER RETAINING WALLS ARE PROTECTED BY ONE OR MORE OF THE FOLLOWING PATENTS: 3,631,682, 4,117,686, 4,260,296, 4,329,089, 4,324,508, 4,343,572, 4,391,557, 4,505,621, 4,616,959, 4,643,618, 4,661,023, 4,856,939, 5,733,072 AND OTHERS PENDING.	<b>REV. NO.</b> 1	<b>DATE</b> 08/11/05	<b>BY</b> DR	<b>DESCRIPTION</b> MINOR REVISIONS, ADDITIONS	<b>GRAPHIC SCALE</b> LINE IS 20 UNITS LONG ON ORIGINAL DRAWING 0 10 20	<b>PROJ. MGR.</b> WBH <b>ENGINEER</b> <b>CADD BY</b> DR	<b>HILFIKER RETAINING WALLS</b> 3900 Broadway Eureka, CA 95503 P.O. Box 2012 Eureka, CA 95501 707-443-5093 Fax 707-443-2891 Toll-Free 800-762-8962 Web: <a href="http://hilfiker.com">http://hilfiker.com</a> email: <a href="mailto:info@hilfiker.com">info@hilfiker.com</a>	<b>1902-2002</b> <b>100 YEARS</b> HILFIKER COMPANY	<b>DWG DATE</b> 1 AUG 05 <b>REVISION DATE</b> 11 AUG 05 <b>SCALE</b> NOTED	<b>SHOP DRAWING</b> STEEPENED SLOPE <b>PANORAMA WEST SUBDIVISION</b> WALL S PIERCE COUNTY, WASHINGTON LINE S-04	<b>PROJECT NO.</b> 050329AS <b>SHEET</b> <b>10</b> OF 45
---	----------------------	-------------------------	-----------------	--	--	---	--	--	---	--	--

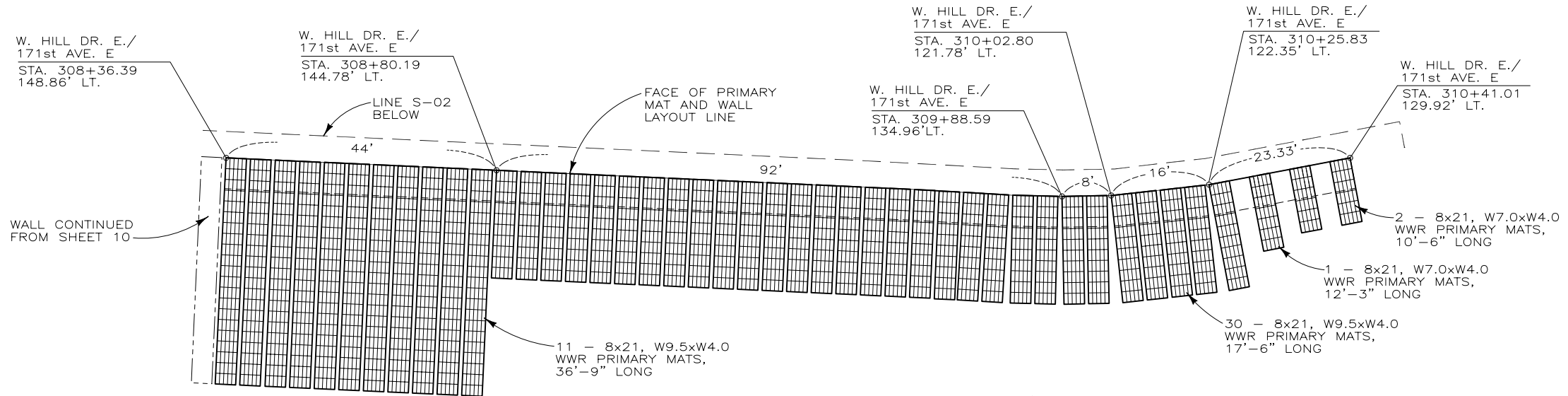

LINE S-04  
ELEVATION 173.04

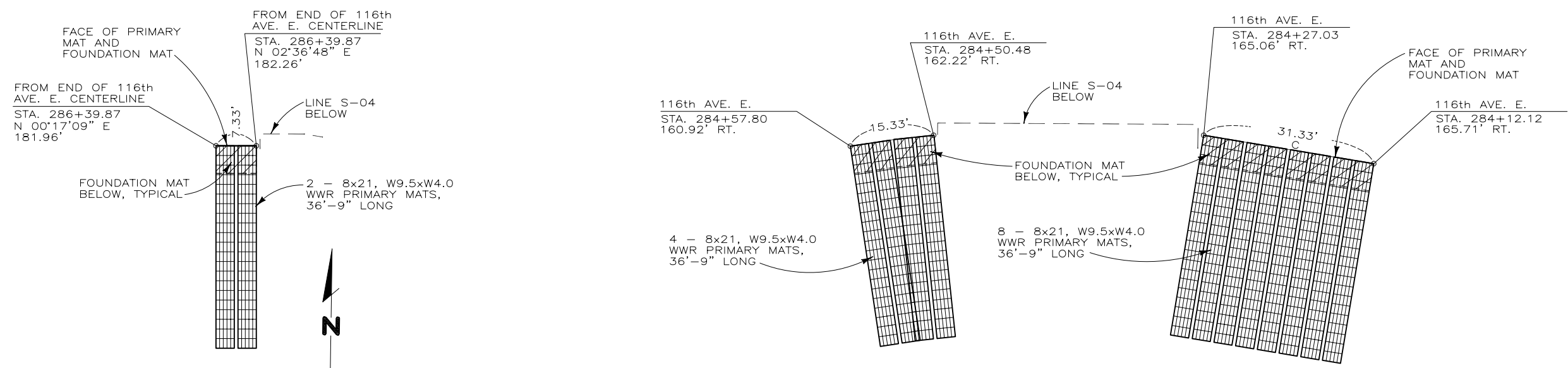
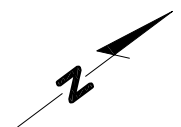

LINE S-05  
ELEVATION 175.18



LINE S-05  
ELEVATION 175.18



**NOTE:**  
ONLY MAJOR POINTS ALONG THE WALL LINES HAVE BEEN LOCATED.

050329AS PANORAMA WALL S

THIS DRAWING IS FURNISHED SOLELY FOR THE USE OF OR IN CONNECTION WITH THIS PROJECT, AND THE PROPRIETARY INFORMATION SHOWN HEREON IS NOT TO BE TRANSMITTED TO ANY OTHER ORGANIZATION WITHOUT SPECIFIC AUTHORIZATION BY THE HILFIKER COMPANY. HILFIKER RETAINING WALLS ARE PROTECTED BY ONE OR MORE OF THE FOLLOWING PATENTS: 3,631,682, 4,117,686, 4,260,296, 4,329,089, 4,324,508, 4,343,572, 4,391,557, 4,505,621, 4,616,959, 4,643,618, 4,661,023, 4,856,939, 5,733,072 AND OTHERS PENDING.

REV. NO.	DATE	BY	DESCRIPTION
1	08/11/05	DR	MINOR REVISIONS, ADDITIONS

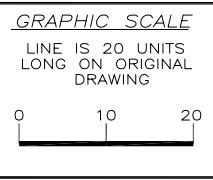

PROJ. MGR.  
WBH  
ENGINEER  
CADD BY  
DR

**HILFIKER RETAINING WALLS**  
3900 Broadway Eureka, CA 95503  
P.O. Box 2012 Eureka, CA 95501  
707-443-5093 Fax 707-443-2891  
Toll-Free 800-762-8962  
Web: <http://hilfiker.com> email: [info@hilfiker.com](mailto:info@hilfiker.com)



DWG DATE  
1 AUG 05  
REVISION DATE  
11 AUG 05  
SCALE  
NOTED

**SHOP DRAWING**  
STEEPENED SLOPE  
**PANORAMA WEST SUBDIVISION**  
WALL S  
PIERCE COUNTY, WASHINGTON  
LINE S-04 AND S-05

PROJECT NO.  
050329AS  
SHEET  
**11**  
OF 45

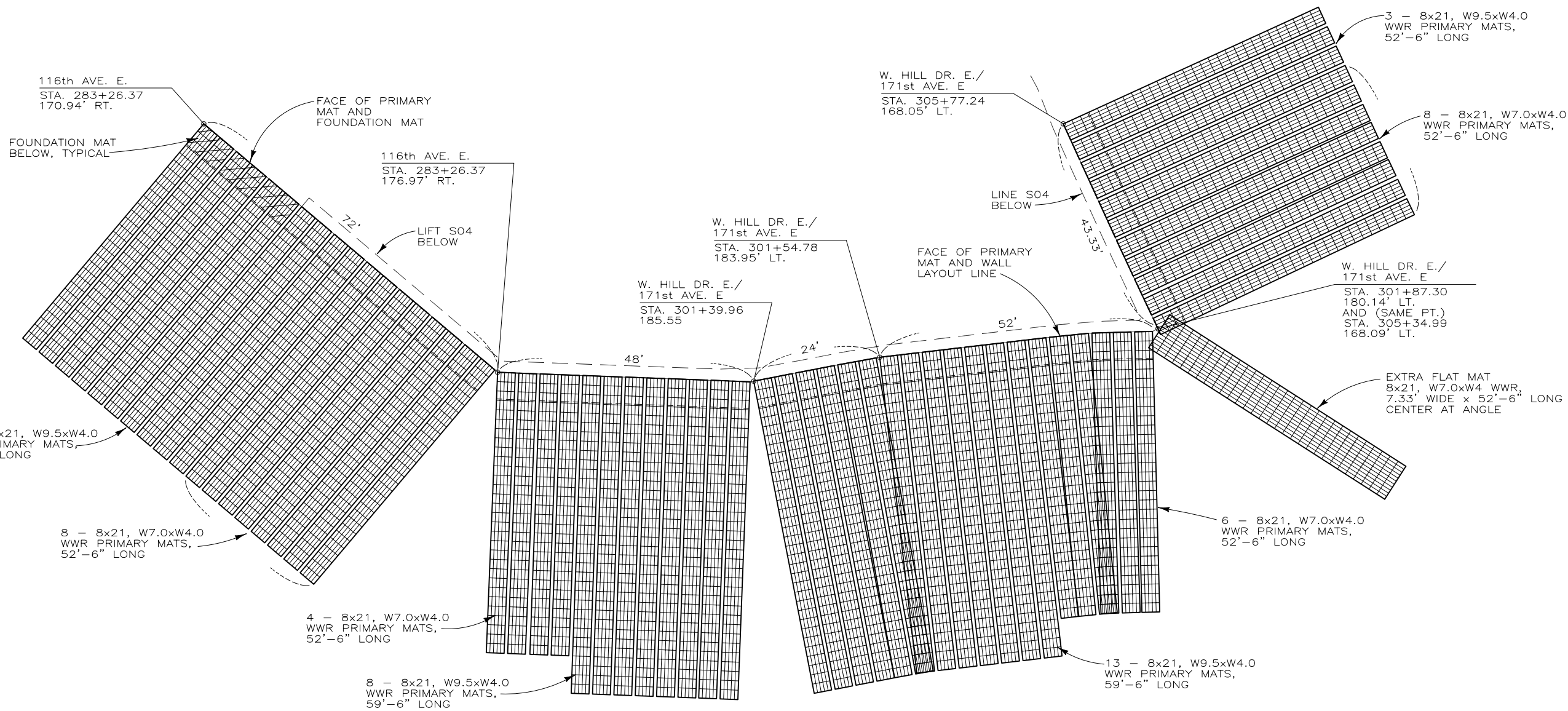

10 - 8x21, W9.5xW4.0  
WWR PRIMARY MATS,  
52'-6" LONG

8 - 8x21, W7.0xW4.0  
WWR PRIMARY MATS,  
52'-6" LONG

4 - 8x21, W7.0xW4.0  
WWR PRIMARY MATS,  
52'-6" LONG

8 - 8x21, W9.5xW4.0  
WWR PRIMARY MATS,  
59'-6" LONG

W. HILL DR. E./  
171st AVE. E.  
STA. 301+39.96  
185.55

LINE S-05  
ELEVATION 175.18

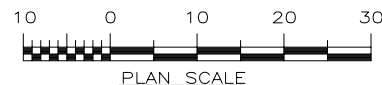

**NOTE:**  
ONLY MAJOR POINTS ALONG  
THE WALL LINES HAVE BEEN  
LOCATED.

050329AS PANORAMA WALL S

THIS DRAWING IS FURNISHED SOLELY FOR THE USE OF OR IN CONNECTION WITH THIS PROJECT, AND THE PROPRIETARY INFORMATION SHOWN HEREON IS NOT TO BE TRANSMITTED TO ANY OTHER ORGANIZATION WITHOUT SPECIFIC AUTHORIZATION BY THE HILFIKER COMPANY. HILFIKER RETAINING WALLS ARE PROTECTED BY ONE OR MORE OF THE FOLLOWING PATENTS: 3,631,682; 4,117,686; 4,260,296; 4,329,089; 4,324,508; 4,343,572; 4,391,557; 4,505,621; 4,616,959; 4,643,618; 4,661,023; 4,856,939; 5,733,072 AND OTHERS PENDING.

REV. NO.	DATE	BY	DESCRIPTION
1	08/11/05	DR	MINOR REVISIONS, ADDITIONS

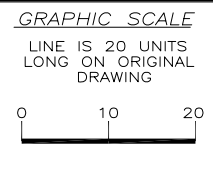

PROJ. MGR.  
WBH  
ENGINEER  
CADD BY  
DR

**HILFIKER RETAINING WALLS**  
3900 Broadway Eureka, CA 95503  
P.O. Box 2012 Eureka, CA 95501  
707-443-5093 Fax 707-443-2891  
Toll-Free 800-762-8962  
Web: <http://hilfiker.com> email: [info@hilfiker.com](mailto:info@hilfiker.com)

DWG DATE	1 AUG 05
REVISION DATE	11 AUG 05
SCALE	NOTED

**SHOP DRAWING**  
STEEPENED SLOPE  
**PANORAMA WEST SUBDIVISION**  
WALL S  
PIERCE COUNTY, WASHINGTON  
LINE S-05

PROJECT NO.  
050329AS  
SHEET  
**12**  
OF 45

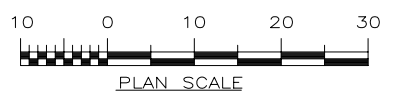
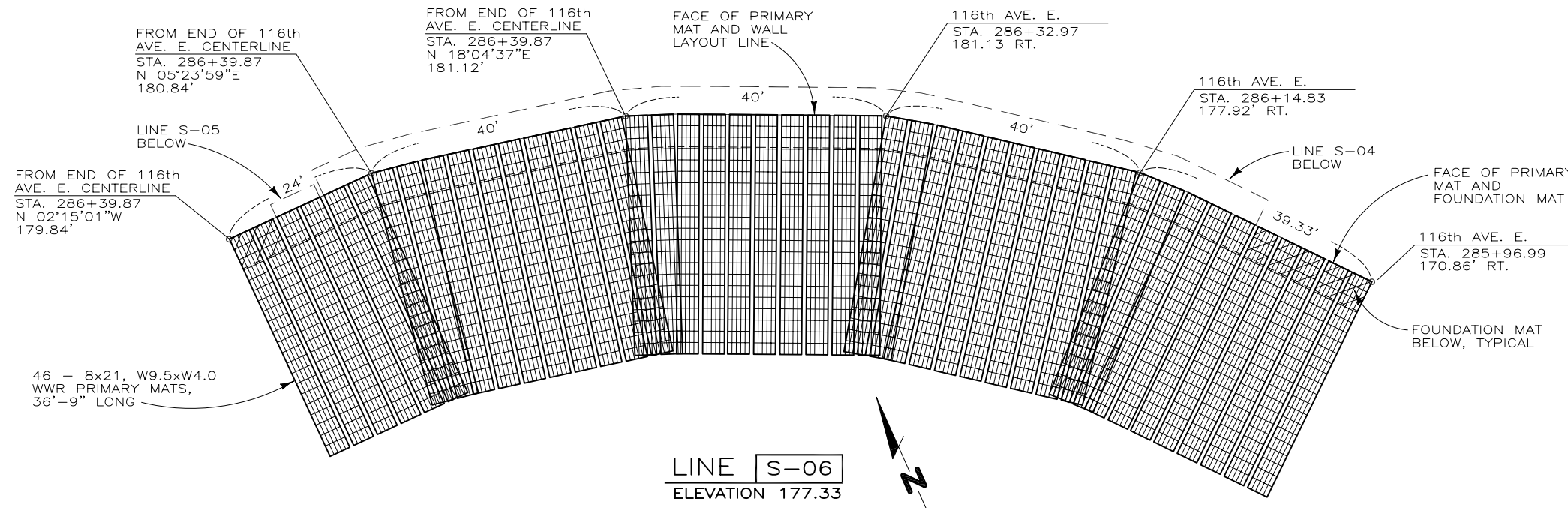

**NOTE:**  
ONLY MAJOR POINTS ALONG THE WALL LINES HAVE BEEN LOCATED.

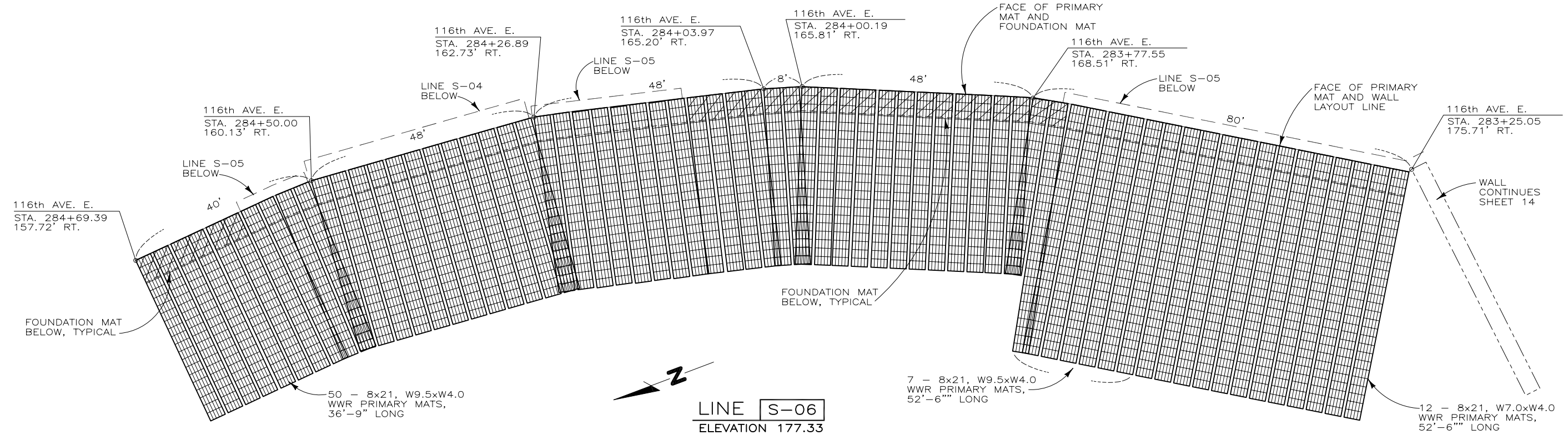

050329AS PANORAMA WALL S

THIS DRAWING IS FURNISHED SOLELY FOR THE USE OF OR IN CONNECTION WITH THIS PROJECT, AND THE PROPRIETARY INFORMATION SHOWN HEREON IS NOT TO BE TRANSMITTED TO ANY OTHER ORGANIZATION WITHOUT SPECIFIC AUTHORIZATION BY THE HILFIKER COMPANY. HILFIKER RETAINING WALLS ARE PROTECTED BY ONE OR MORE OF THE FOLLOWING PATENTS: 3,631,682, 4,117,686, 4,260,296, 4,329,089, 4,324,508, 4,343,572, 4,391,557, 4,505,621, 4,616,959, 4,643,618, 4,661,023, 4,656,939, 5,733,072 AND OTHERS PENDING.

REV.NO.	DATE	BY	DESCRIPTION
1	08/11/05	DR	MINOR REVISIONS, ADDITIONS

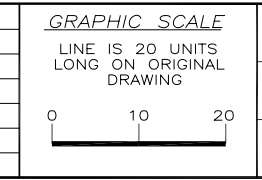

PROJ. MGR.  
WBH  
ENGINEER  
CADD BY  
DR

**HILFIKER RETAINING WALLS**  
3900 Broadway Eureka, CA 95503  
P.O. Box 2012 Eureka, CA 95501  
707-443-5093 Fax 707-443-2891  
Toll-Free 800-762-8962  
Web: <http://hilfiker.com> email: [info@hilfiker.com](mailto:info@hilfiker.com)

DWG DATE  
1 AUG 05  
REVISION DATE  
11 AUG 05  
SCALE  
NOTED

**SHOP DRAWING**  
STEEPENED SLOPE  
**PANORAMA WEST SUBDIVISION**  
WALL S  
PIERCE COUNTY, WASHINGTON  
LINE S-06

PROJECT NO.  
050329AS  
SHEET  
**13**  
OF 45



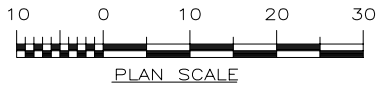
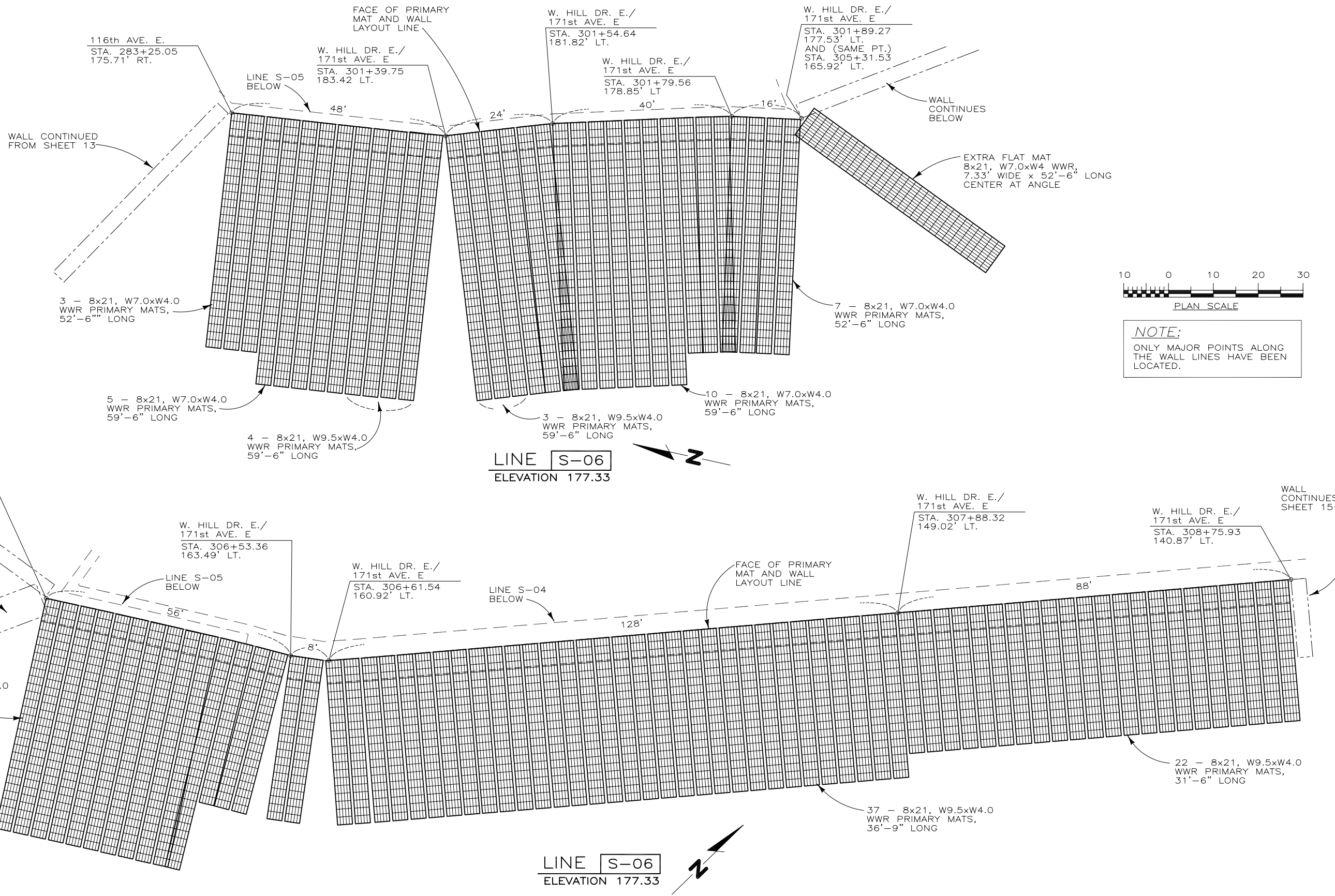

**NOTE:**  
ONLY MAJOR POINTS ALONG  
THE WALL LINES HAVE BEEN  
LOCATED.

050329AS PANORAMA WALL S

THIS DRAWING IS FURNISHED SOLELY FOR THE USE OF OR IN CONNECTION WITH THIS PROJECT, AND THE PROPRIETARY INFORMATION SHOWN HEREON IS NOT TO BE TRANSMITTED TO ANY OTHER ORGANIZATION WITHOUT SPECIFIC AUTHORIZATION BY THE HILFIKER COMPANY. HILFIKER RETAINING WALLS ARE PROTECTED BY ONE OR MORE OF THE FOLLOWING PATENTS: 3,631,682, 4,117,686, 4,260,296, 4,329,089, 4,324,508, 4,343,572, 4,391,557, 4,505,621, 4,616,959, 4,643,618, 4,661,023, 4,856,939, 5,733,072 AND OTHERS PENDING.	REV. NO.	DATE	BY	DESCRIPTION	GRAPHIC SCALE LINE IS 20 UNITS LONG ON ORIGINAL DRAWING 	PROJ. MGR. WBH	<b>HILFIKER RETAINING WALLS</b> 3900 Broadway Eureka, CA 95503 P.O. Box 2012 Eureka, CA 95501 707-443-5093 Fax 707-443-2891 Toll-Free 800-762-8962 Web: <a href="http://hilfiker.com">http://hilfiker.com</a> email: <a href="mailto:info@hilfiker.com">info@hilfiker.com</a>	DWG DATE 1 AUG 05	<b>SHOP DRAWING</b> STEEPENED SLOPE <b>PANORAMA WEST SUBDIVISION</b> WALL S PIERCE COUNTY, WASHINGTON LINE S-06	PROJECT NO. 050329AS
	1	08/11/05	DR	MINOR REVISIONS, ADDITIONS		ENGINEER		REVISION DATE 11 AUG 05		SHEET <b>14</b> OF 45

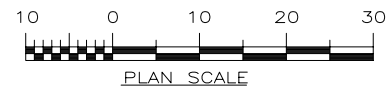
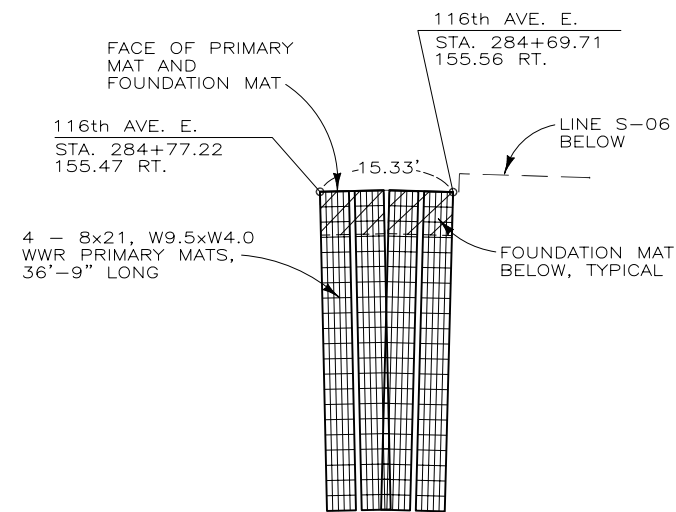
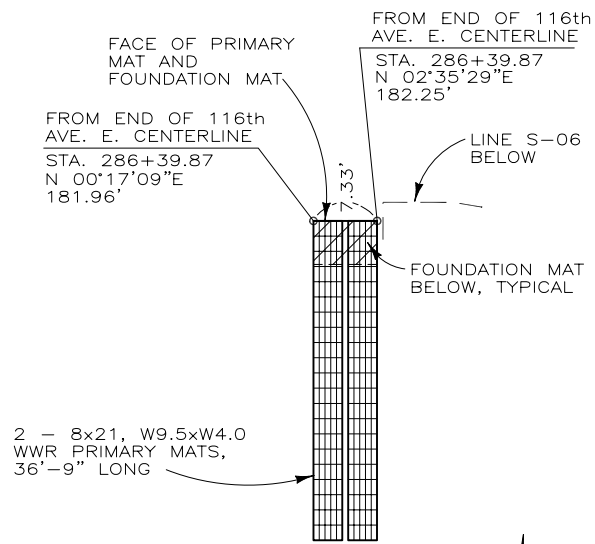
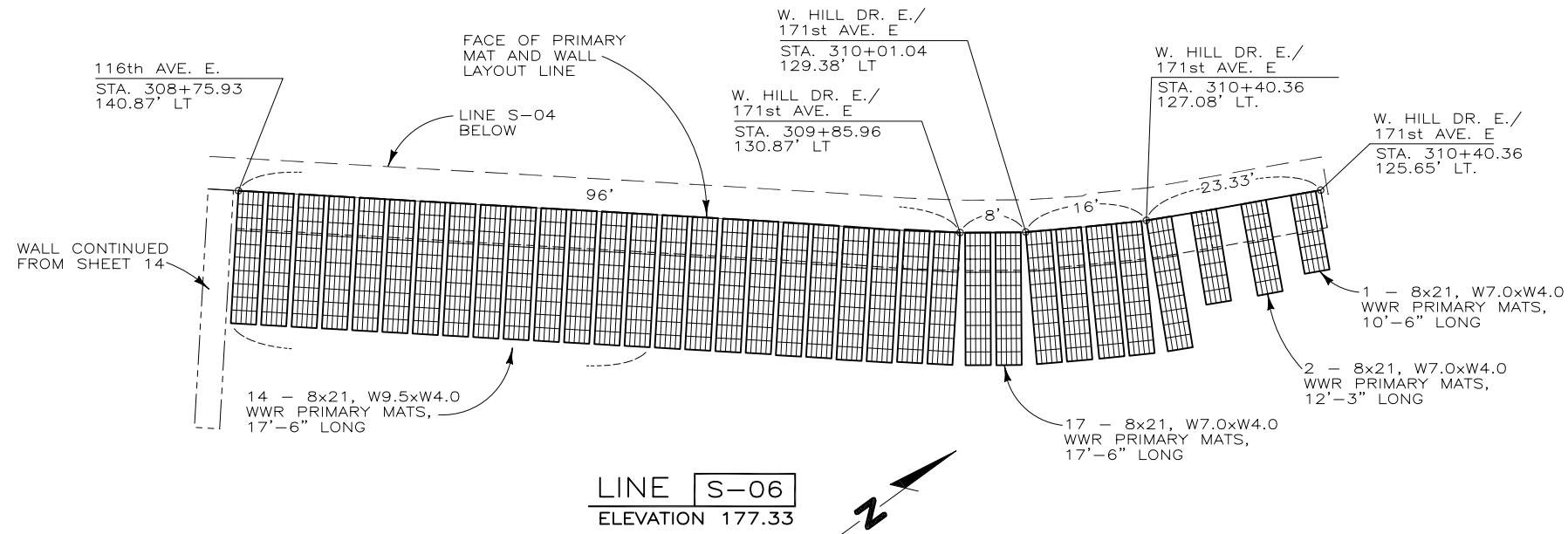

**NOTE:**  
ONLY MAJOR POINTS ALONG THE WALL LINES HAVE BEEN LOCATED.

050329AS PANORAMA WALL S

THIS DRAWING IS FURNISHED SOLELY FOR THE USE OF OR IN CONNECTION WITH THIS PROJECT, AND THE PROPRIETARY INFORMATION SHOWN HEREON IS NOT TO BE TRANSMITTED TO ANY OTHER ORGANIZATION WITHOUT SPECIFIC AUTHORIZATION BY THE HILFIKER COMPANY. HILFIKER RETAINING WALLS ARE PROTECTED BY ONE OR MORE OF THE FOLLOWING PATENTS: 3,631,682, 4,117,686, 4,260,296, 4,329,089, 4,324,508, 4,343,572, 4,391,557, 4,505,621, 4,616,959, 4,643,618, 4,661,023, 4,856,939, 5,733,072 AND OTHERS PENDING.

REV. NO.	DATE	BY	DESCRIPTION
1	08/11/05	DR	MINOR REVISIONS, ADDITIONS

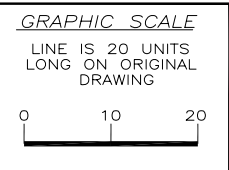

PROJ. MGR.  
WBH  
ENGINEER  
CADD BY  
DR

**HILFIKER RETAINING WALLS**  
3900 Broadway Eureka, CA 95503  
P.O. Box 2012 Eureka, CA 95501  
707-443-5093 Fax 707-443-2891  
Toll-Free 800-762-8962  
Web: <http://hilfiker.com> email: [info@hilfiker.com](mailto:info@hilfiker.com)



DWG DATE  
1 AUG 05  
REVISION DATE  
11 AUG 05  
SCALE  
NOTED

**SHOP DRAWING**  
STEEPENED SLOPE  
**PANORAMA WEST SUBDIVISION**  
WALL S  
PIERCE COUNTY, WASHINGTON  
LINE S-06 AND S-07

PROJECT NO.  
050329AS  
SHEET  
**15**  
OF 45

116th AVE. E.  
STA. 283+75.20  
166.65' RT.

116th AVE. E.  
STA. 283+24.19  
173.81' RT.

W. HILL DR. E./  
171st AVE. E.  
STA. 305+75.58  
163.74' LT

12 - 8x21, W7.0xW4.0  
WWR PRIMARY MATS,  
52'-6" LONG

W. HILL DR. E./  
171st AVE. E.  
STA. 301+38.98  
181.38' LT

W. HILL DR. E./  
171st AVE. E.  
STA. 301+91.22  
175.11' LT.  
AND (SAME PT.)  
STA. 305+28.25  
163.76' LT.

FACE OF PRIMARY  
MAT AND WALL  
LAYOUT LINE

LINE S-06  
BELOW

EXTRA FLAT MAT  
8x21, W7.0xW4 WWR,  
7.33' WIDE x 52'-6" LONG  
CENTER AT ANGLE

19 - 8x21, W7.0xW4.0  
WWR PRIMARY MATS,  
52'-6" LONG

4 - 8x21, W7.0xW4.0  
WWR PRIMARY MATS,  
52'-6" LONG

5 - 8x21, W7.0xW4.0  
WWR PRIMARY MATS,  
59'-6" LONG

3 - 8x21, W9.5xW4.0  
WWR PRIMARY MATS,  
59'-6" LONG

8 - 8x21, W7.0xW4.0  
WWR PRIMARY MATS,  
52'-6" LONG

10 - 8x21, W7.0xW4.0  
WWR PRIMARY MATS,  
59'-6" LONG

3 - 8x21, W9.5xW4.0  
WWR PRIMARY MATS,  
59'-6" LONG

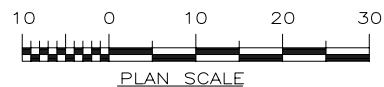

LINE S-07  
ELEVATION 179.48

**NOTE:**

ONLY MAJOR POINTS ALONG  
THE WALL LINES HAVE BEEN  
LOCATED.

050329AS PANORAMA WALL S

THIS DRAWING IS FURNISHED SOLELY FOR THE USE OF OR IN CONNECTION WITH THIS PROJECT, AND THE PROPRIETARY INFORMATION SHOWN HEREON IS NOT TO BE TRANSMITTED TO ANY OTHER ORGANIZATION WITHOUT SPECIFIC AUTHORIZATION BY THE HILFIKER COMPANY. HILFIKER RETAINING WALLS ARE PROTECTED BY ONE OR MORE OF THE FOLLOWING PATENTS: 3,631,682; 4,117,686; 4,260,296; 4,329,089; 4,324,308; 4,343,572; 4,391,557; 4,505,621; 4,616,959; 4,643,618; 4,661,023; 4,856,939; 5,733,072 AND OTHERS PENDING.

REV. NO.	DATE	BY	DESCRIPTION
1	08/11/05	DR	MINOR REVISIONS, ADDITIONS

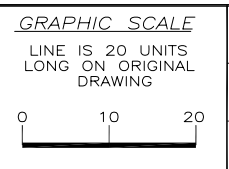

PROJ. MGR.  
WBH  
ENGINEER  
CADD BY  
DR

**HILFIKER RETAINING WALLS**  
3900 Broadway Eureka, CA 95503  
P.O. Box 2012 Eureka, CA 95501  
707-443-5093 Fax 707-443-2891  
Toll-Free 800-762-8962  
Web: <http://hilfiker.com> email: [info@hilfiker.com](mailto:info@hilfiker.com)



DWG DATE  
1 AUG 05  
REVISION DATE  
11 AUG 05  
SCALE  
NOTED

**SHOP DRAWING**  
STEEPENED SLOPE  
**PANORAMA WEST SUBDIVISION**  
WALL S  
PIERCE COUNTY, WASHINGTON  
LINE S-07

PROJECT NO.  
050329AS  
SHEET  
**16**  
OF 45



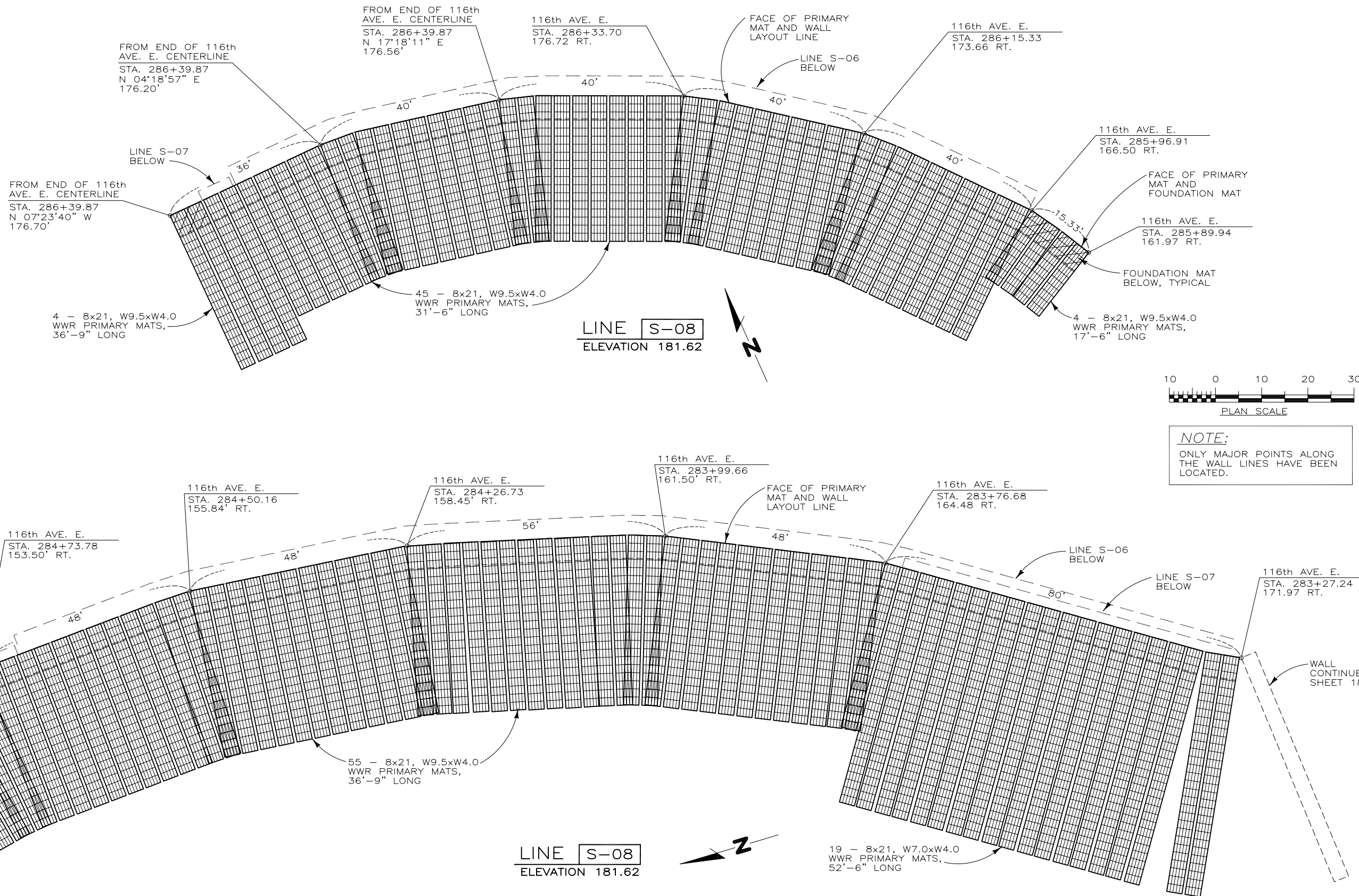

050329AS PANORAMA WALL S

THIS DRAWING IS FURNISHED SOLELY FOR THE USE OF OR IN CONNECTION WITH THIS PROJECT, AND THE PROPRIETARY INFORMATION SHOWN HEREON IS NOT TO BE TRANSMITTED TO ANY OTHER ORGANIZATION WITHOUT SPECIFIC AUTHORIZATION BY THE HILFIKER COMPANY. HILFIKER RETAINING WALLS ARE PROTECTED BY ONE OR MORE OF THE FOLLOWING PATENTS: 3,631,682, 4,117,686, 4,260,296, 4,329,089, 4,324,508, 4,343,572, 4,391,557, 4,505,621, 4,616,959, 4,643,618, 4,661,023, 4,856,939, 5,733,072 AND OTHERS PENDING.

REV. NO.	DATE	BY	DESCRIPTION
1	08/11/05	DR	MINOR REVISIONS, ADDITIONS

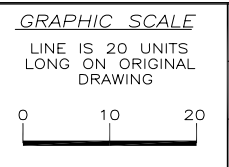

PROJ. MGR.  
WBH

ENGINEER

CADD BY  
DR

**HILFIKER RETAINING WALLS**  
3900 Broadway Eureka, CA 95503  
P.O. Box 2012 Eureka, CA 95501  
707-443-5093 Fax 707-443-2891  
Toll-Free 800-762-8962  
Web: <http://hilfiker.com> email: [info@hilfiker.com](mailto:info@hilfiker.com)



DWG DATE  
1 AUG 05

REVISION DATE  
11 AUG 05

SCALE  
NOTED

**SHOP DRAWING**

STEEPENED SLOPE  
**PANORAMA WEST SUBDIVISION**  
WALL S  
PIERCE COUNTY, WASHINGTON

LINE S-08

PROJECT NO.  
050329AS

SHEET  
**17**  
OF 45

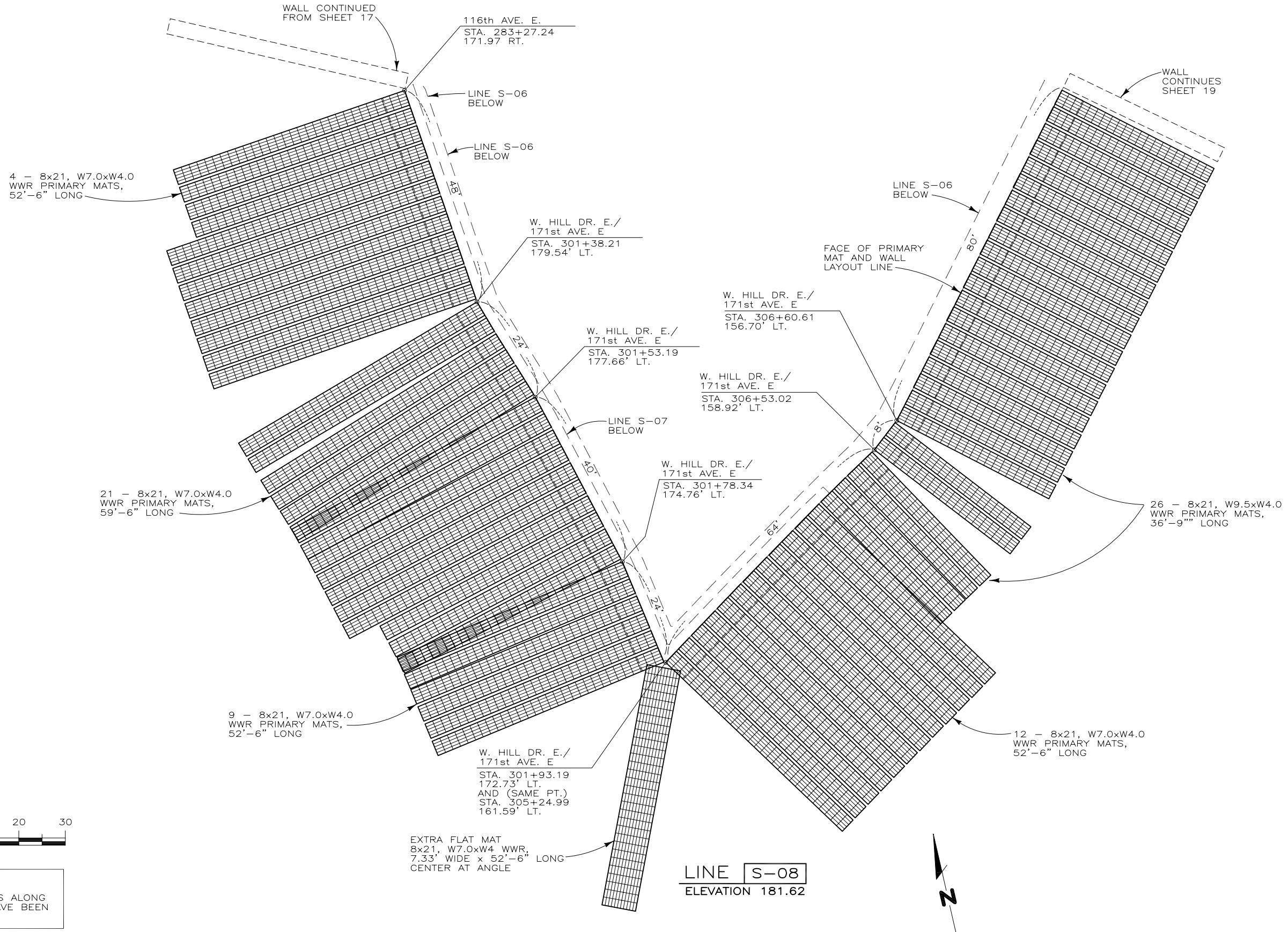

**NOTE:**  
ONLY MAJOR POINTS ALONG THE WALL LINES HAVE BEEN LOCATED.

050329AS PANORAMA WALL S

THIS DRAWING IS FURNISHED SOLELY FOR THE USE OF OR IN CONNECTION WITH THIS PROJECT, AND THE PROPRIETARY INFORMATION SHOWN HEREON IS NOT TO BE TRANSMITTED TO ANY OTHER ORGANIZATION WITHOUT SPECIFIC AUTHORIZATION BY THE HILFIKER COMPANY. HILFIKER RETAINING WALLS ARE PROTECTED BY ONE OR MORE OF THE FOLLOWING PATENTS: 3,631,682, 4,117,686, 4,260,296, 4,329,089, 4,324,308, 4,343,572, 4,391,557, 4,505,621, 4,616,959, 4,643,618, 4,661,023, 4,856,939, 5,733,072 AND OTHERS PENDING.

REV. NO.	DATE	BY	DESCRIPTION
1	08/11/05	DR	MINOR REVISIONS, ADDITIONS

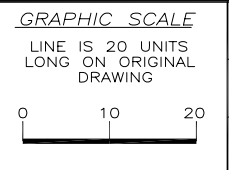

PROJ. MGR.  
WBH  
ENGINEER  
CADD BY  
DR

**HILFIKER RETAINING WALLS**  
3900 Broadway Eureka, CA 95503  
P.O. Box 2012 Eureka, CA 95501  
707-443-5093 Fax 707-443-2891  
Toll-Free 800-762-8962  
Web: <http://hilfiker.com> email: [info@hilfiker.com](mailto:info@hilfiker.com)

DWG DATE	1 AUG 05
REVISION DATE	11 AUG 05
SCALE	NOTED

**SHOP DRAWING**  
STEEPENED SLOPE  
**PANORAMA WEST SUBDIVISION**  
WALL S  
PIERCE COUNTY, WASHINGTON  
LINE S-08

PROJECT NO.  
050329AS  
SHEET  
**18**  
OF 45

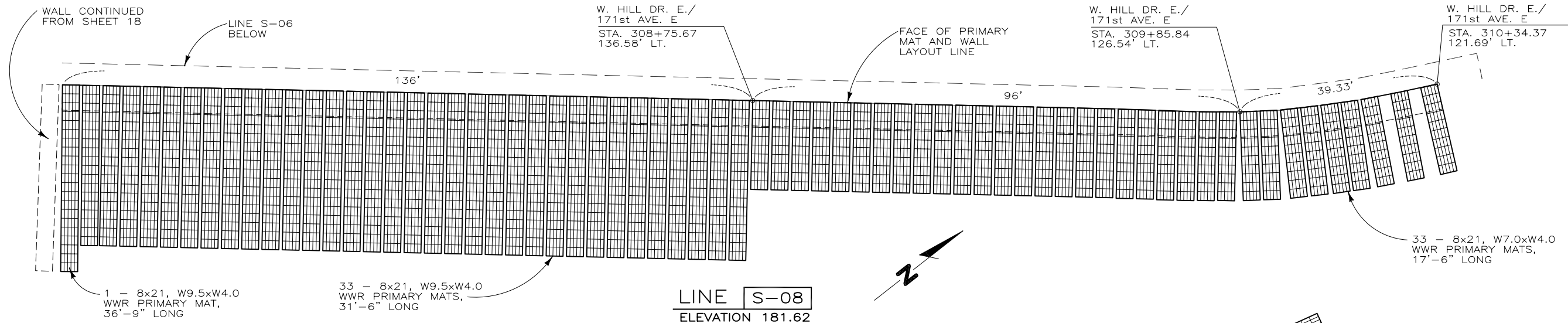

**LINE S-08**  
ELEVATION 181.62

**NOTE:**  
ONLY MAJOR POINTS ALONG THE WALL LINES HAVE BEEN LOCATED.

116th AVE. E.  
STA. 283+78.17  
161.95 RT.

116th AVE. E.  
STA. 283+74.33  
162.33 RT.

2 - 8x21, W9.5xW4.0  
WWR PRIMARY MATS,  
36'-9" LONG

W. HILL DR. E./  
171st AVE. E.  
STA. 305+77.02  
159.40 LT.

14 - 8x21, W7.0xW4.0  
WWR PRIMARY MATS,  
42'-0" LONG

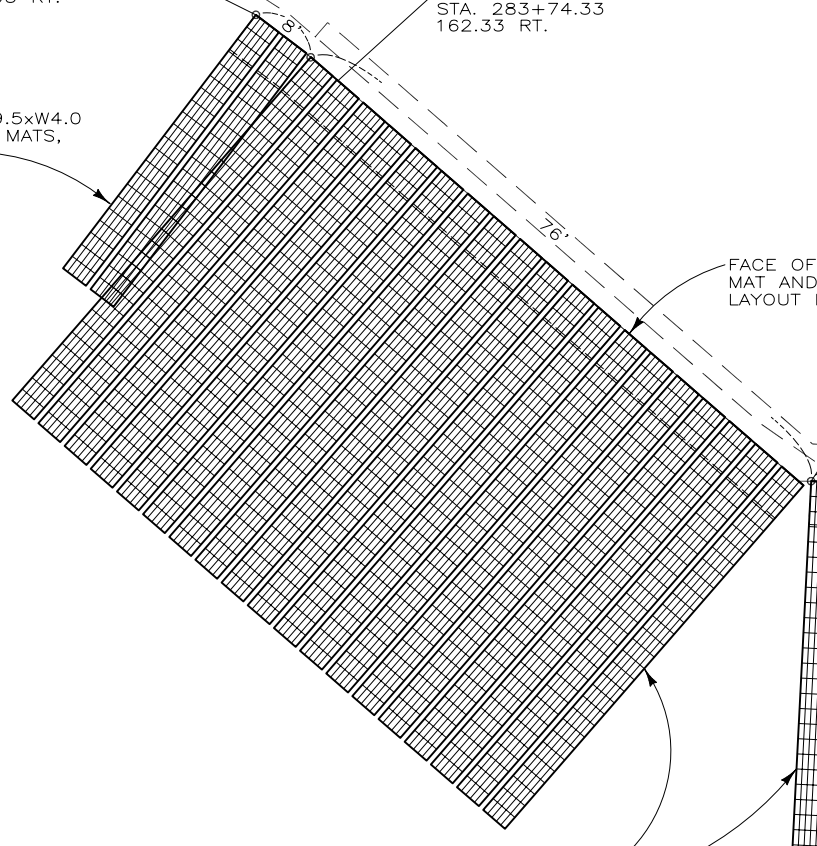

W. HILL DR. E./  
171st AVE. E.  
STA. 301+95.18  
170.33 LT.  
AND (SAME PT.)  
STA. 305+21.69  
159.42 LT.

EXTRA FLAT MAT  
8x21, W7.0xW4 WWR,  
7.33' WIDE x 52'-6" LONG  
CENTER AT ANGLE

23 - 8x21, W7.0xW4.0  
WWR PRIMARY MATS,  
52'-6" LONG

21 - 8x21, W7.0xW4.0  
WWR PRIMARY MATS,  
59'-6" LONG

**LINE S-09**  
ELEVATION 183.77

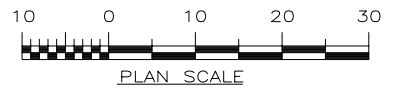

050329AS PANORAMA WALL S

THIS DRAWING IS FURNISHED SOLELY FOR THE USE OF OR IN CONNECTION WITH THIS PROJECT, AND THE PROPRIETARY INFORMATION SHOWN HEREON IS NOT TO BE TRANSMITTED TO ANY OTHER ORGANIZATION WITHOUT SPECIFIC AUTHORIZATION BY THE HILFIKER COMPANY. HILFIKER RETAINING WALLS ARE PROTECTED BY ONE OR MORE OF THE FOLLOWING PATENTS: 3,631,682, 4,117,686, 4,260,296, 4,329,089, 4,324,508, 4,343,572, 4,391,557, 4,505,621, 4,616,959, 4,643,618, 4,661,023, 4,856,939, 5,733,072 AND OTHERS PENDING.

REV. NO.	DATE	BY	DESCRIPTION
1	08/11/05	DR	MINOR REVISIONS, ADDITIONS

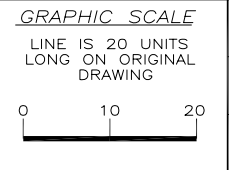

PROJ. MGR.  
WBH  
ENGINEER  
CADD BY  
DR

**HILFIKER RETAINING WALLS**  
3900 Broadway Eureka, CA 95503  
P.O. Box 2012 Eureka, CA 95501  
707-443-5093 Fax 707-443-2891  
Toll-Free 800-762-8962  
Web: <http://hilfiker.com> email: [info@hilfiker.com](mailto:info@hilfiker.com)



DWG DATE  
2 AUG 05  
REVISION DATE  
11 AUG 05  
SCALE  
NOTED

**SHOP DRAWING**  
STEEPENED SLOPE  
**PANORAMA WEST SUBDIVISION**  
WALL S  
PIERCE COUNTY, WASHINGTON  
LINE S-08 AND S-09

PROJECT NO.  
050329AS  
SHEET  
**19**  
OF 45

050329AS PANORAMA WALL S

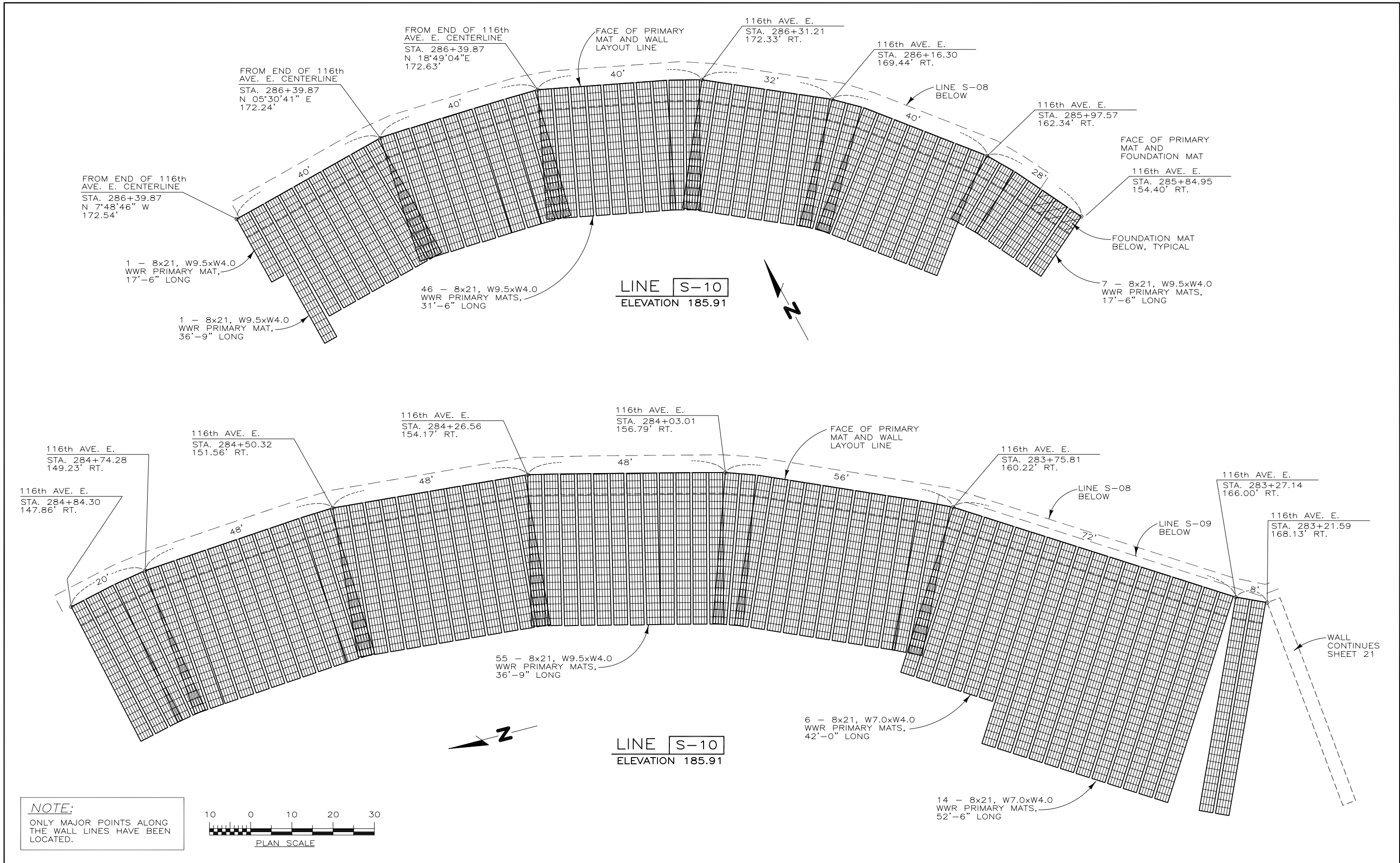

**NOTE:**  
 ONLY MAJOR POINTS ALONG THE WALL LINES HAVE BEEN LOCATED.

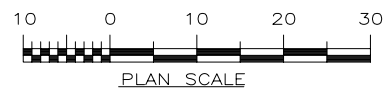

REV. NO.	DATE	BY	DESCRIPTION
1	08/11/05	DR	MINOR REVISIONS, ADDITIONS

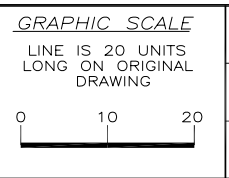

PROJ. MGR.  
 WBH  
 ENGINEER  
 CADD BY  
 DR

**HILFIKER RETAINING WALLS**  
 3900 Broadway Eureka, CA 95503  
 P.O. Box 2012 Eureka, CA 95501  
 707-443-5093 Fax 707-443-2891  
 Toll-Free 800-762-8962  
 Web: <http://hilfiker.com> email: [info@hilfiker.com](mailto:info@hilfiker.com)

DWG DATE  
 8 AUG 05  
 REVISION DATE  
 11 AUG 05  
 SCALE  
 NOTED

**SHOP DRAWING**  
 STEEPENED SLOPE  
**PANORAMA WEST SUBDIVISION**  
 WALL S  
 PIERCE COUNTY, WASHINGTON  
 LINE S-10

PROJECT NO.  
 050329AS  
 SHEET  
**20**  
 OF 45



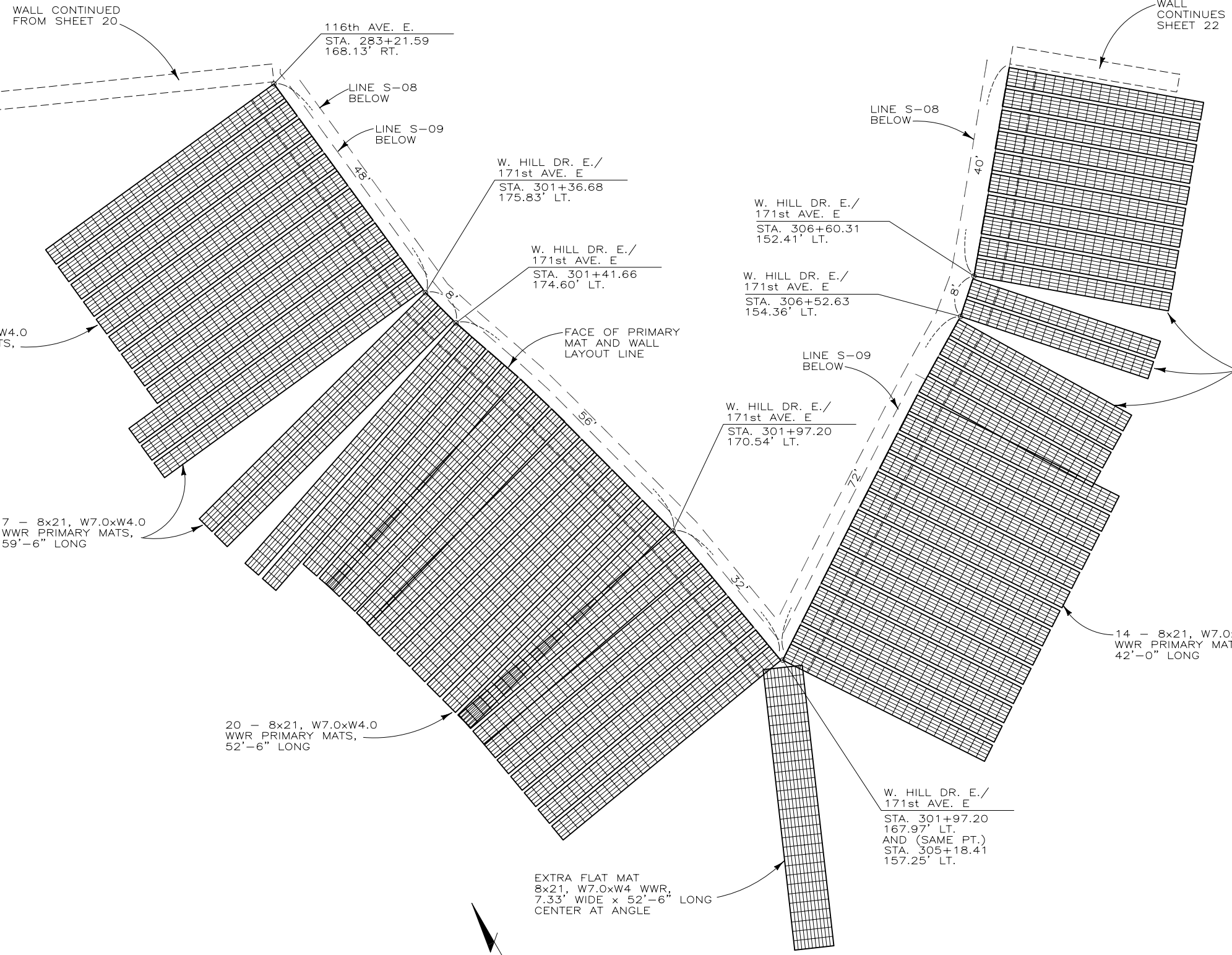

**NOTE:**  
 ONLY MAJOR POINTS ALONG  
 THE WALL LINES HAVE BEEN  
 LOCATED.

**LINE S-10**  
 ELEVATION 185.91

O50329AS PANORAMA WALL S

THIS DRAWING IS FURNISHED SOLELY FOR THE USE OF OR IN CONNECTION WITH THIS PROJECT, AND THE PROPRIETARY INFORMATION SHOWN HEREON IS NOT TO BE TRANSMITTED TO ANY OTHER ORGANIZATION WITHOUT SPECIFIC AUTHORIZATION BY THE HILFIKER COMPANY. HILFIKER RETAINING WALLS ARE PROTECTED BY ONE OR MORE OF THE FOLLOWING PATENTS: 3,631,682, 4,117,686, 4,260,296, 4,329,089, 4,324,508, 4,343,572, 4,391,557, 4,505,621, 4,616,959, 4,643,618, 4,661,023, 4,856,939, 5,733,072 AND OTHERS PENDING.

REV. NO.	DATE	BY	DESCRIPTION
1	08/11/05	DR	MINOR REVISIONS, ADDITIONS

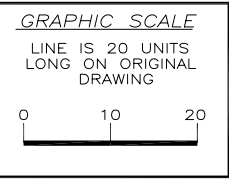

**PROJ. MGR.**  
WBH

**ENGINEER**

**CADD BY**  
DR

**HILFIKER RETAINING WALLS**  
 3900 Broadway Eureka, CA 95503  
 P.O. Box 2012 Eureka, CA 95501  
 707-443-5093 Fax 707-443-2891  
 Toll-Free 800-762-8962  
 Web: <http://hilfiker.com> email: [info@hilfiker.com](mailto:info@hilfiker.com)



**DWG DATE**  
8 AUG 05

**REVISION DATE**  
11 AUG 05

**SCALE**  
NOTED

**SHOP DRAWING**

STEEPENED SLOPE  
**PANORAMA WEST SUBDIVISION**  
 WALL S  
 PIERCE COUNTY, WASHINGTON

LINE S-10

**PROJECT NO.**  
O50329AS

**SHEET**  
**21**  
OF 45

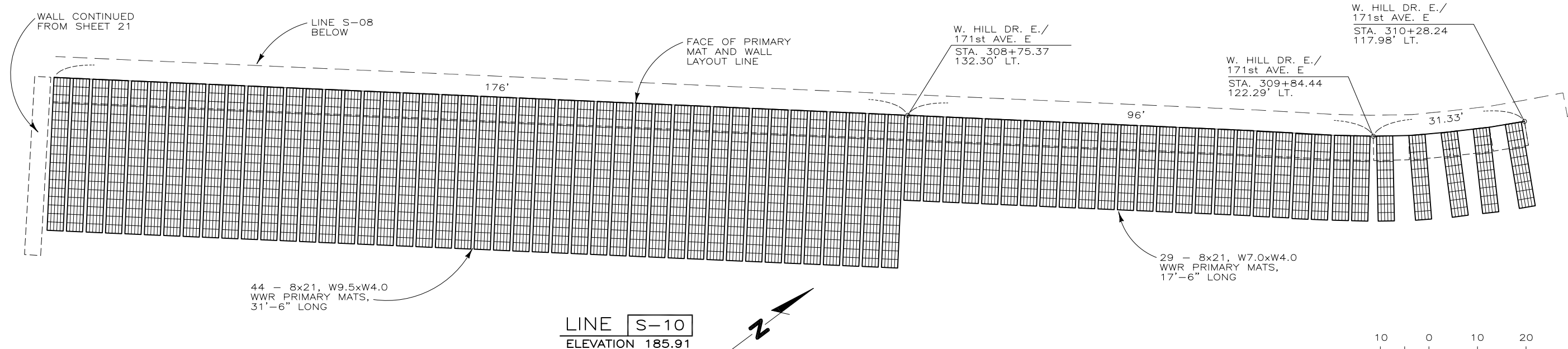

LINE S-10  
ELEVATION 185.91

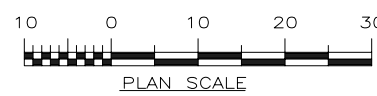

**NOTE:**  
ONLY MAJOR POINTS ALONG THE WALL LINES HAVE BEEN LOCATED.

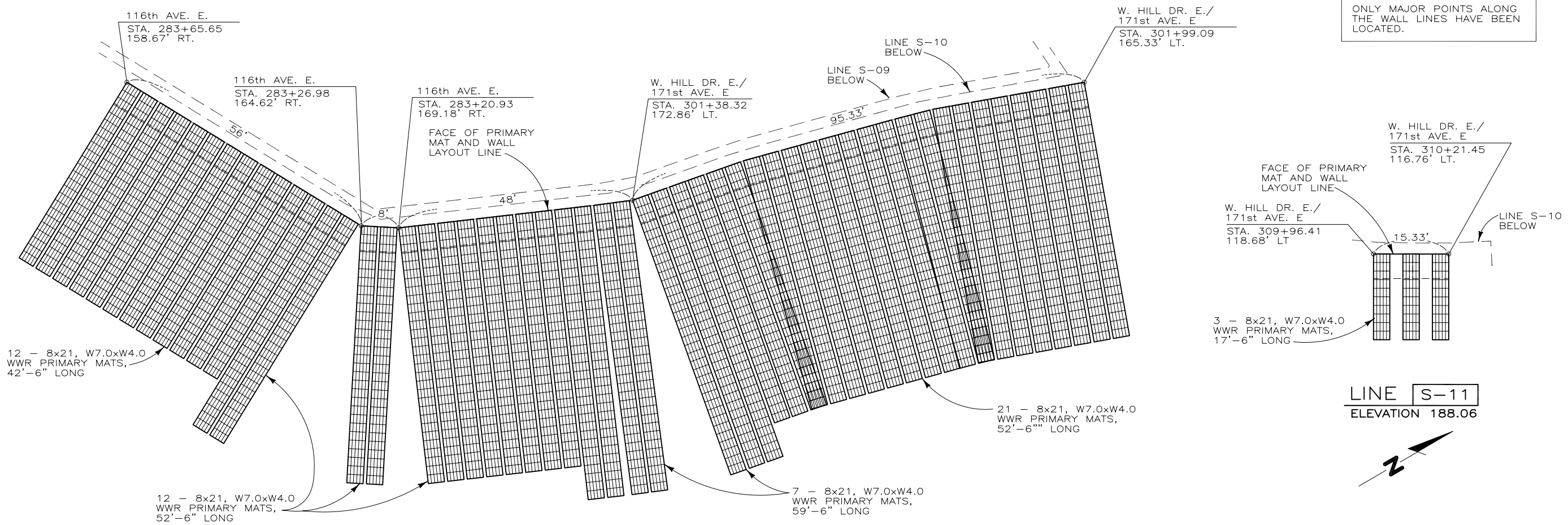

LINE S-11  
ELEVATION 188.06

LINE S-11  
ELEVATION 188.06

050329AS PANORAMA WALL S

THIS DRAWING IS FURNISHED SOLELY FOR THE USE OF OR IN CONNECTION WITH THIS PROJECT, AND THE PROPRIETARY INFORMATION SHOWN HEREON IS NOT TO BE TRANSMITTED TO ANY OTHER ORGANIZATION WITHOUT SPECIFIC AUTHORIZATION BY THE HILFIKER COMPANY. HILFIKER RETAINING WALLS ARE PROTECTED BY ONE OR MORE OF THE FOLLOWING PATENTS: 3,631,682, 4,117,686, 4,260,296, 4,329,089, 4,324,508, 4,343,572, 4,391,557, 4,505,621, 4,616,959, 4,643,618, 4,661,023, 4,856,939, 5,733,072 AND OTHERS PENDING.

REV. NO.	DATE	BY	DESCRIPTION
1	08/11/05	DR	MINOR REVISIONS, ADDITIONS

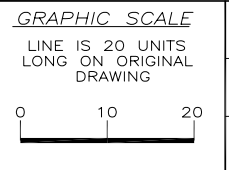

PROJ. MGR.  
WBH  
ENGINEER  
CADD BY  
DR

**HILFIKER RETAINING WALLS**  
3900 Broadway Eureka, CA 95503  
P.O. Box 2012 Eureka, CA 95501  
707-443-5093 Fax 707-443-2891  
Toll-Free 800-762-8962  
Web: <http://hilfiker.com> email: [info@hilfiker.com](mailto:info@hilfiker.com)



DWG DATE  
8 AUG 05  
REVISION DATE  
11 AUG 05  
SCALE  
NOTED

**SHOP DRAWING**  
STEEPENED SLOPE  
**PANORAMA WEST SUBDIVISION**  
WALL S  
PIERCE COUNTY, WASHINGTON  
LINE S-10 AND S-11

PROJECT NO.  
050329AS  
SHEET  
**22**  
OF 45

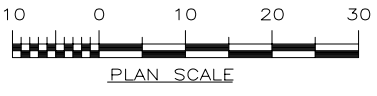
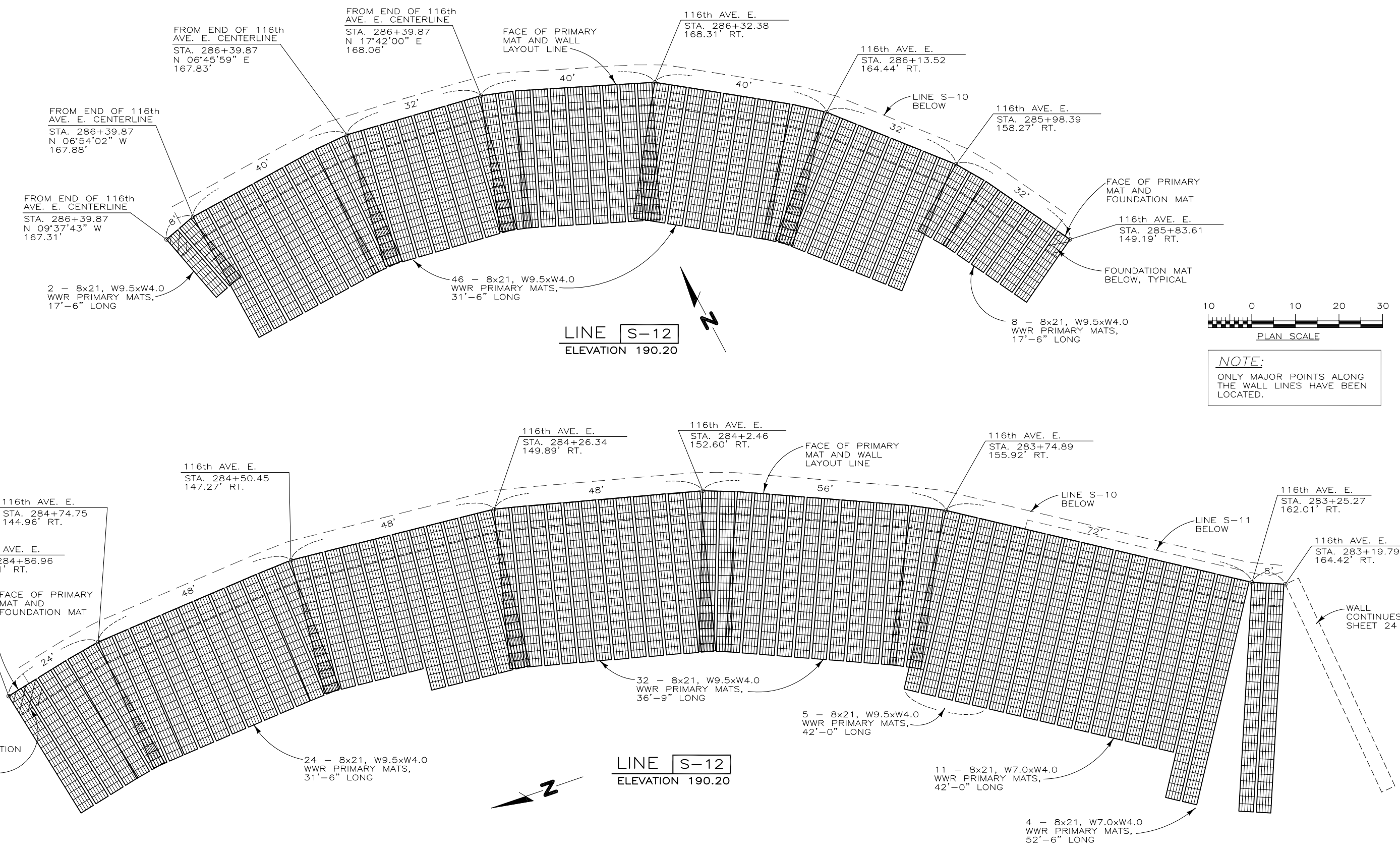

**NOTE:**  
ONLY MAJOR POINTS ALONG THE WALL LINES HAVE BEEN LOCATED.

050329AS PANORAMA WALL S

THIS DRAWING IS FURNISHED SOLELY FOR THE USE OF OR IN CONNECTION WITH THIS PROJECT, AND THE PROPRIETARY INFORMATION SHOWN HEREON IS NOT TO BE TRANSMITTED TO ANY OTHER ORGANIZATION WITHOUT SPECIFIC AUTHORIZATION BY THE HILFIKER COMPANY. HILFIKER RETAINING WALLS ARE PROTECTED BY ONE OR MORE OF THE FOLLOWING PATENTS: 3,631,682, 4,117,686, 4,260,296, 4,329,089, 4,324,508, 4,343,572, 4,391,557, 4,505,621, 4,616,959, 4,643,618, 4,661,023, 4,856,939, 5,733,072 AND OTHERS PENDING.

REV. NO.	DATE	BY	DESCRIPTION
1	08/11/05	DR	MINOR REVISIONS, ADDITIONS

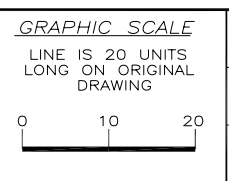

PROJ. MGR.  
WBH  
ENGINEER  
CADD BY  
DR

**HILFIKER RETAINING WALLS**  
3900 Broadway Eureka, CA 95503  
P.O. Box 2012 Eureka, CA 95501  
707-443-5093 Fax 707-443-2891  
Toll-Free 800-762-8962  
Web: <http://hilfiker.com> email: [info@hilfiker.com](mailto:info@hilfiker.com)



DWG DATE  
8 AUG 05  
REVISION DATE  
11 AUG 05  
SCALE  
NOTED

**SHOP DRAWING**  
STEEPENED SLOPE  
**PANORAMA WEST SUBDIVISION**  
WALL S  
PIERCE COUNTY, WASHINGTON  
LINE S-12

PROJECT NO.  
050329AS  
SHEET  
**23**  
OF 45

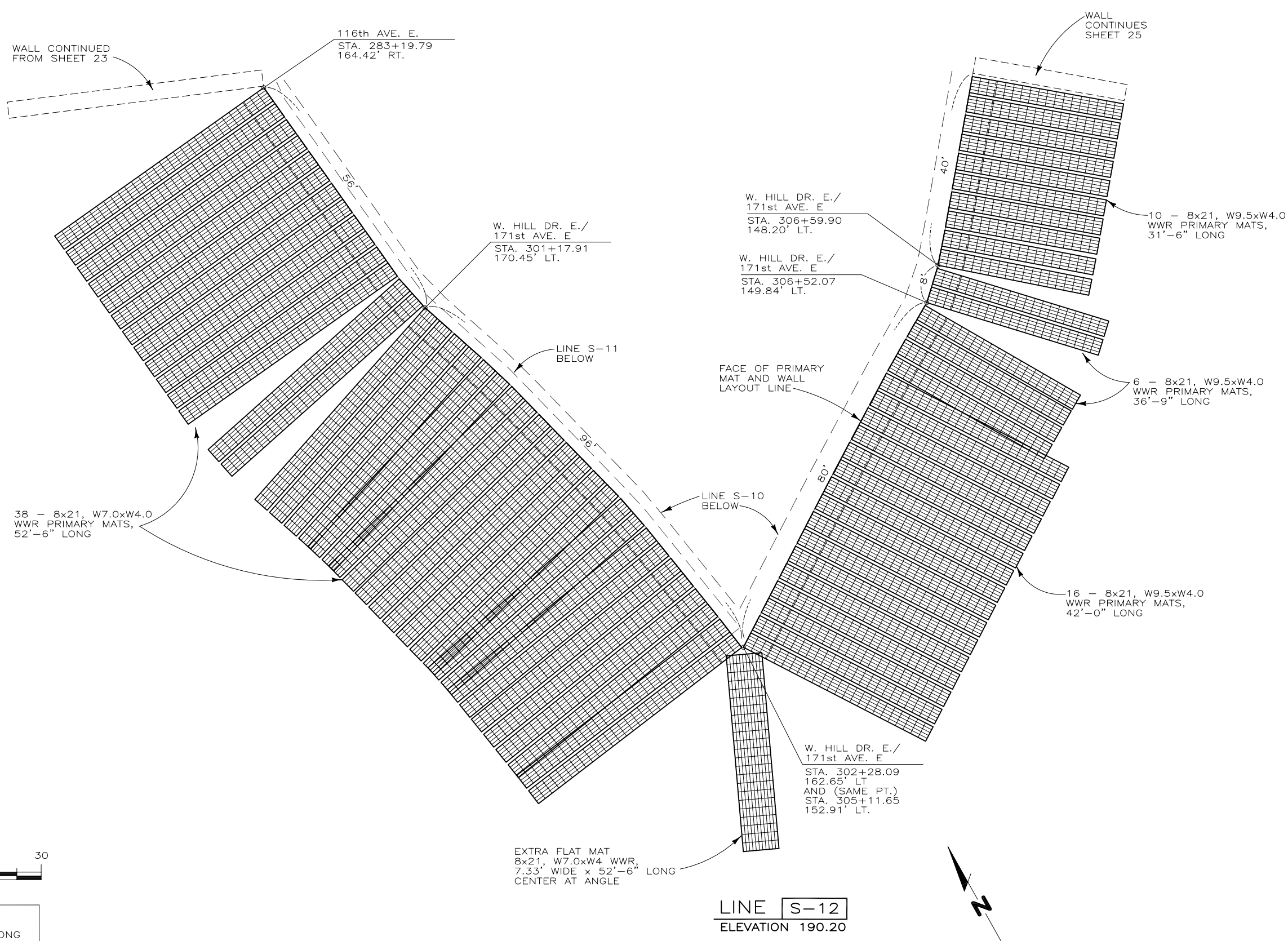

**NOTE:**  
ONLY MAJOR POINTS ALONG THE WALL LINES HAVE BEEN LOCATED.

050329AS PANORAMA WALL S

REV. NO.	DATE	BY	DESCRIPTION
1	08/11/05	DR	MINOR REVISIONS, ADDITIONS

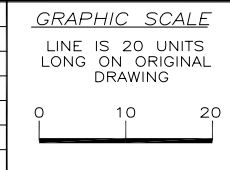

PROJ. MGR.  
WBH  
ENGINEER  
CADD BY  
DR

**HILFIKER RETAINING WALLS**  
3900 Broadway Eureka, CA 95503  
P.O. Box 2012 Eureka, CA 95501  
707-443-5093 Fax 707-443-2891  
Toll-Free 800-762-8962  
Web: <http://hilfiker.com> email: [info@hilfiker.com](mailto:info@hilfiker.com)

DWG DATE  
8 AUG 05  
REVISION DATE  
11 AUG 05  
SCALE  
NOTED

**SHOP DRAWING**  
STEEPENED SLOPE  
**PANORAMA WEST SUBDIVISION**  
WALL S  
PIERCE COUNTY, WASHINGTON  
LINE S-12

PROJECT NO.  
050329AS  
SHEET  
**24**  
OF 45



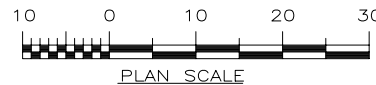
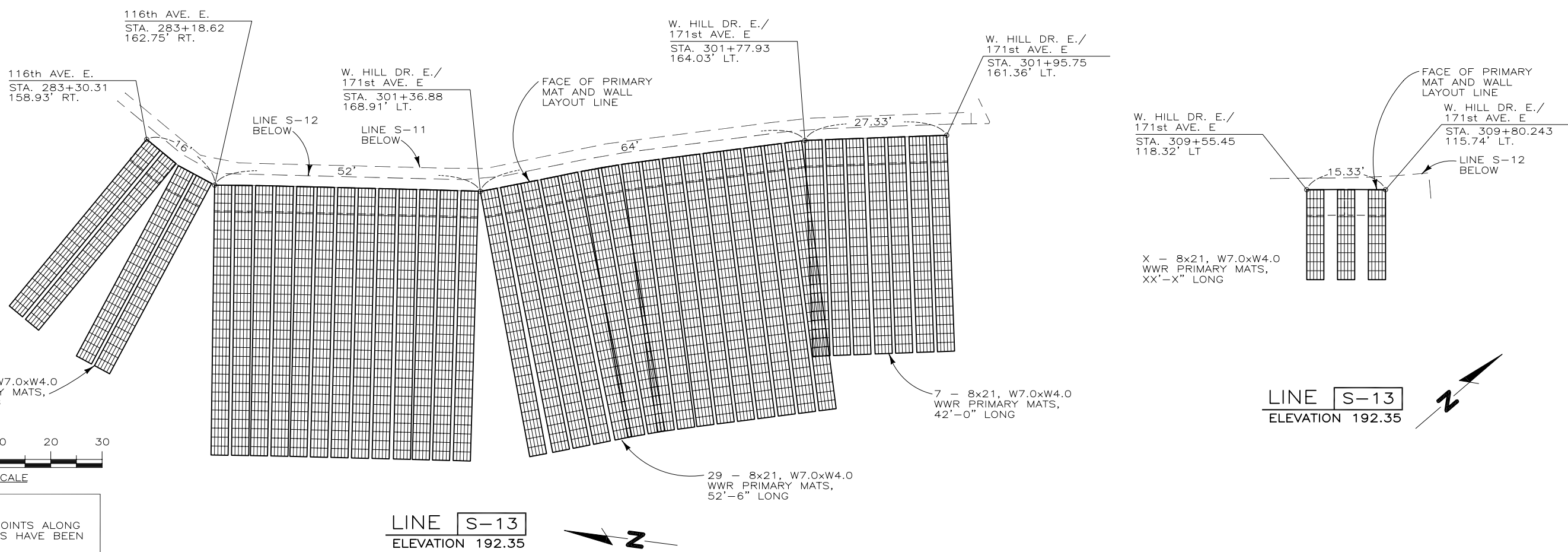
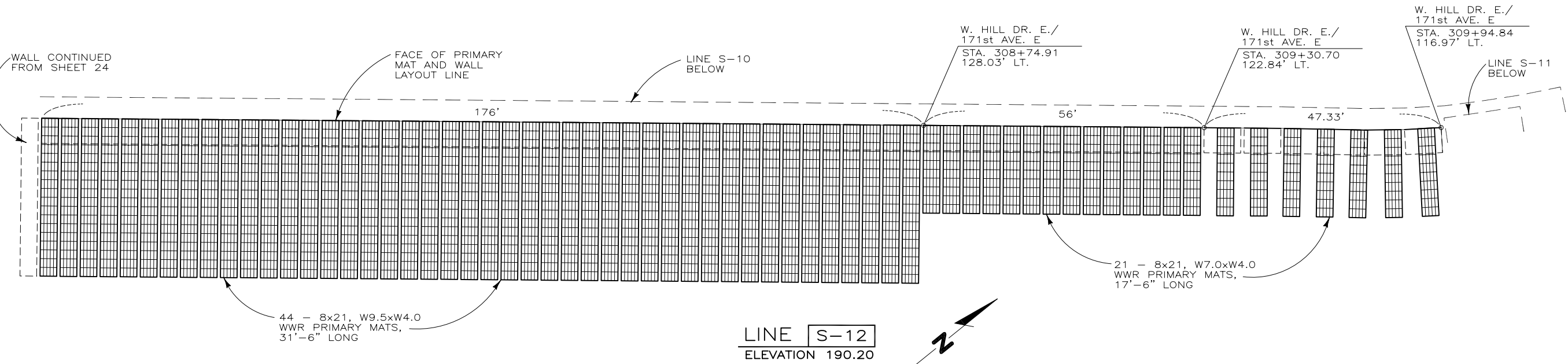

**NOTE:**  
ONLY MAJOR POINTS ALONG THE WALL LINES HAVE BEEN LOCATED.

**LINE S-13**  
ELEVATION 192.35

**LINE S-13**  
ELEVATION 192.35

050329AS PANORAMA WALL S

THIS DRAWING IS FURNISHED SOLELY FOR THE USE OF OR IN CONNECTION WITH THIS PROJECT, AND THE PROPRIETARY INFORMATION SHOWN HEREON IS NOT TO BE TRANSMITTED TO ANY OTHER ORGANIZATION WITHOUT SPECIFIC AUTHORIZATION BY THE HILFIKER COMPANY. HILFIKER RETAINING WALLS ARE PROTECTED BY ONE OR MORE OF THE FOLLOWING PATENTS: 3,631,682, 4,117,686, 4,260,296, 4,329,089, 4,324,508, 4,343,572, 4,391,557, 4,505,621, 4,616,959, 4,643,618, 4,661,023, 4,856,939, 5,733,072 AND OTHERS PENDING.	REV. NO. 1	DATE 08/11/05	BY DR	DESCRIPTION MINOR REVISIONS, ADDITIONS	<b>GRAPHIC SCALE</b> LINE IS 20 UNITS LONG ON ORIGINAL DRAWING 	PROJ. MGR. WBH	<b>HILFIKER RETAINING WALLS</b> 3900 Broadway Eureka, CA 95503  P.O. Box 2012 Eureka, CA 95501 707-443-5093 Fax 707-443-2891 Toll-Free 800-762-8962 Web: <a href="http://hilfiker.com">http://hilfiker.com</a> email: <a href="mailto:info@hilfiker.com">info@hilfiker.com</a>	DWG DATE 8 AUG 05	<b>SHOP DRAWING</b> STEEPENED SLOPE <b>PANORAMA WEST SUBDIVISION</b> WALL S PIERCE COUNTY, WASHINGTON	PROJECT NO. 050329AS
	REVISION DATE 11 AUG 05	SCALE NOTED	SHEET <b>25</b> OF 45							

050329AS PANORAMA WALL S

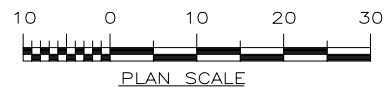
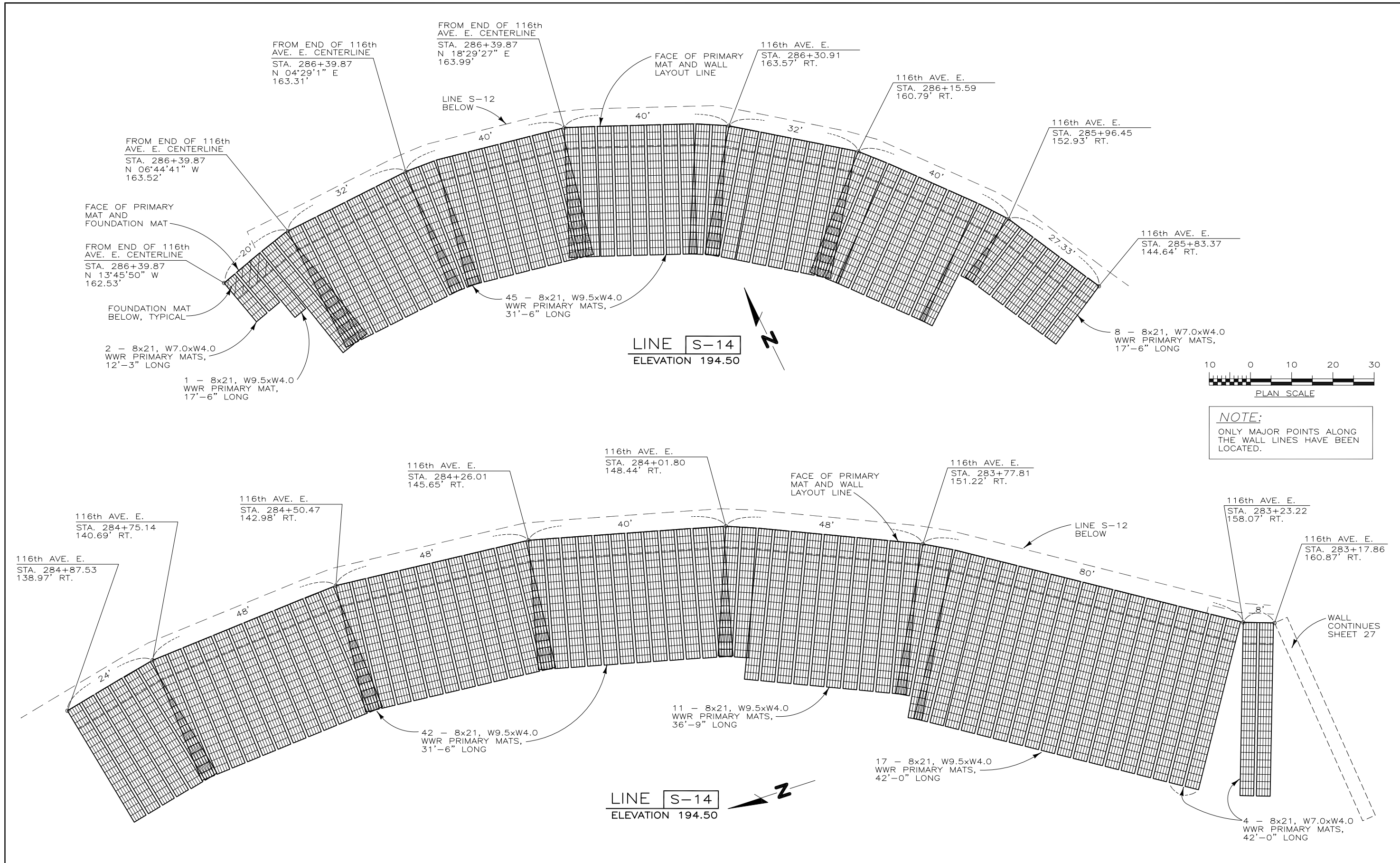

**NOTE:**  
ONLY MAJOR POINTS ALONG THE WALL LINES HAVE BEEN LOCATED.

THIS DRAWING IS FURNISHED SOLELY FOR THE USE OF OR IN CONNECTION WITH THIS PROJECT, AND THE PROPRIETARY INFORMATION SHOWN HEREON IS NOT TO BE TRANSMITTED TO ANY OTHER ORGANIZATION WITHOUT SPECIFIC AUTHORIZATION BY THE HILFIKER COMPANY. HILFIKER RETAINING WALLS ARE PROTECTED BY ONE OR MORE OF THE FOLLOWING PATENTS: 3,631,682; 4,117,686; 4,260,296; 4,329,089; 4,324,508; 4,343,572; 4,391,557; 4,505,621; 4,616,959; 4,643,618; 4,661,023; 4,856,939; 5,733,072 AND OTHERS PENDING.

REV. NO.	DATE	BY	DESCRIPTION
1	08/11/05	DR	MINOR REVISIONS, ADDITIONS

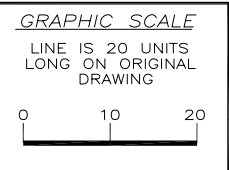

PROJ. MGR.  
WBH

ENGINEER

CADD BY  
DR

**HILFIKER RETAINING WALLS**  
3900 Broadway Eureka, CA 95503  
P.O. Box 2012 Eureka, CA 95501  
707-443-5093 Fax 707-443-2891  
Toll-Free 800-762-8962  
Web: <http://hilfiker.com> email: [info@hilfiker.com](mailto:info@hilfiker.com)



DWG DATE  
8 AUG 05

REVISION DATE  
11 AUG 05

SCALE  
NOTED

**SHOP DRAWING**

STEEPENED SLOPE  
**PANORAMA WEST SUBDIVISION**  
WALL S  
PIERCE COUNTY, WASHINGTON

LINE S-14

PROJECT NO.  
050329AS

SHEET  
**26**  
OF 45

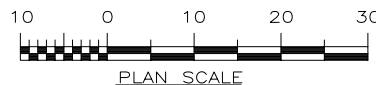
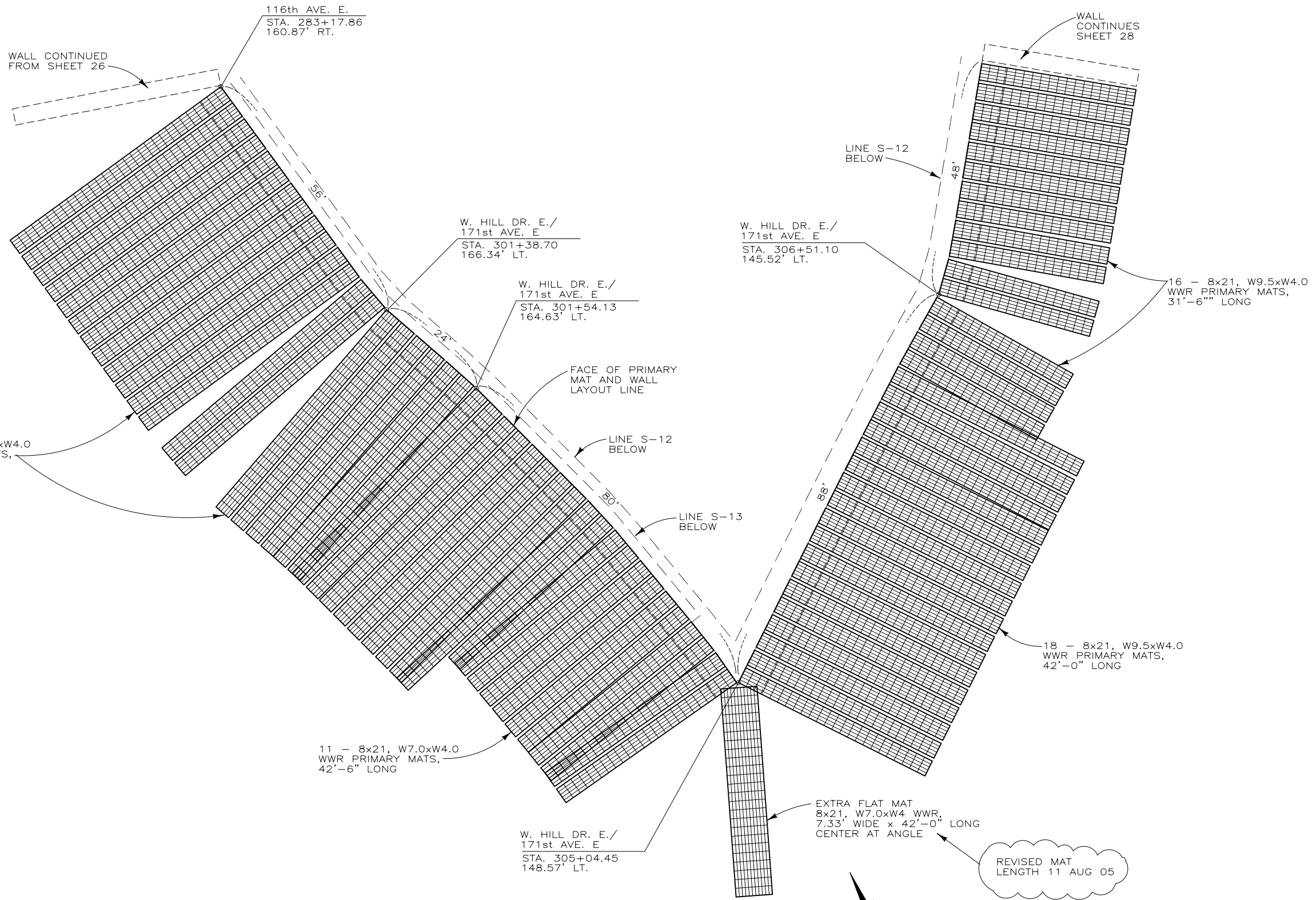

**NOTE:**  
ONLY MAJOR POINTS ALONG THE WALL LINES HAVE BEEN LOCATED.

**LINE S-14**  
ELEVATION 194.50

050329AS PANORAMA WALL S

THIS DRAWING IS FURNISHED SOLELY FOR THE USE OF OR IN CONNECTION WITH THIS PROJECT, AND THE PROPRIETARY INFORMATION SHOWN HEREON IS NOT TO BE TRANSMITTED TO ANY OTHER ORGANIZATION WITHOUT SPECIFIC AUTHORIZATION BY THE HILFIKER COMPANY. HILFIKER RETAINING WALLS ARE PROTECTED BY ONE OR MORE OF THE FOLLOWING PATENTS: 3,631,682, 4,117,686, 4,260,296, 4,329,089, 4,324,508, 4,343,572, 4,391,557, 4,505,621, 4,616,959, 4,643,618, 4,661,023, 4,856,939, 5,733,072 AND OTHERS PENDING.

REV. NO.	DATE	BY	DESCRIPTION
1	08/11/05	DR	MINOR REVISIONS, ADDITIONS

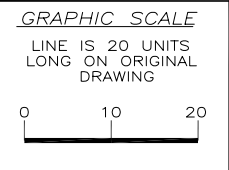

**PROJ. MGR.**  
WBH  
**ENGINEER**  
**CADD BY**  
DR

**HILFIKER RETAINING WALLS**  
3900 Broadway Eureka, CA 95503  
P.O. Box 2012 Eureka, CA 95501  
707-443-5093 Fax 707-443-2891  
Toll-Free 800-762-8962  
Web: <http://hilfiker.com> email: [info@hilfiker.com](mailto:info@hilfiker.com)

**DWG DATE**  
8 AUG 05  
**REVISION DATE**  
11 AUG 05  
**SCALE**  
NOTED

**SHOP DRAWING**  
STEEPENED SLOPE  
**PANORAMA WEST SUBDIVISION**  
WALL S  
PIERCE COUNTY, WASHINGTON  
LINE S-14

**PROJECT NO.**  
050329AS  
**SHEET**  
**27**  
OF 45

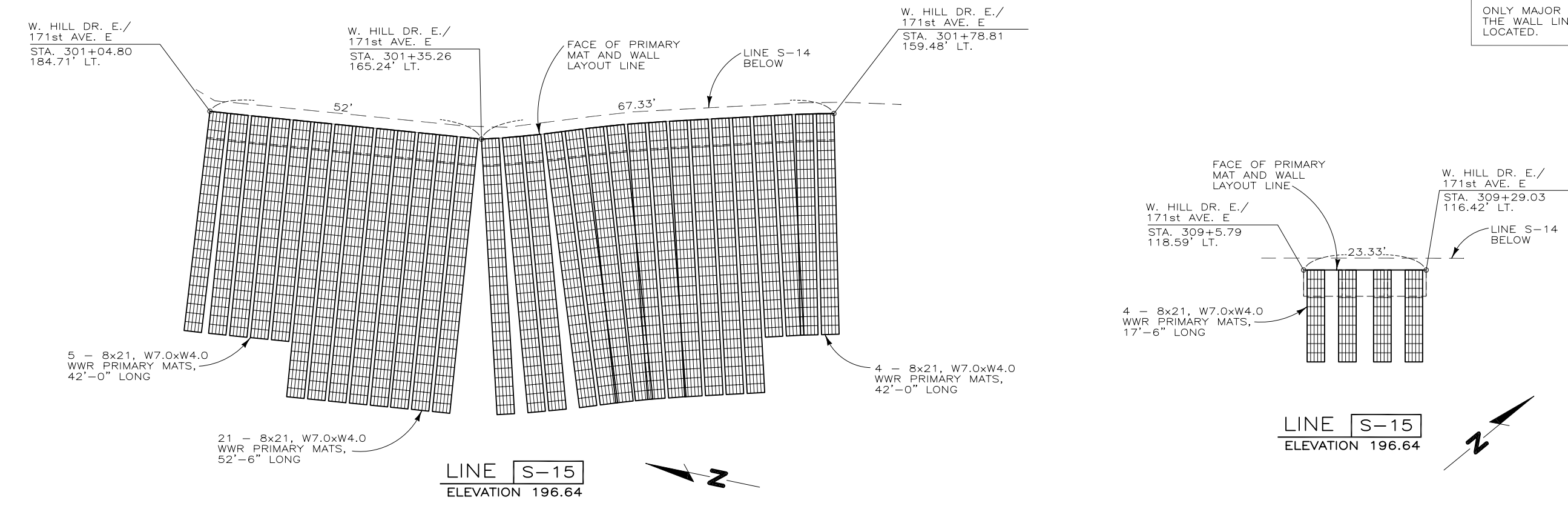
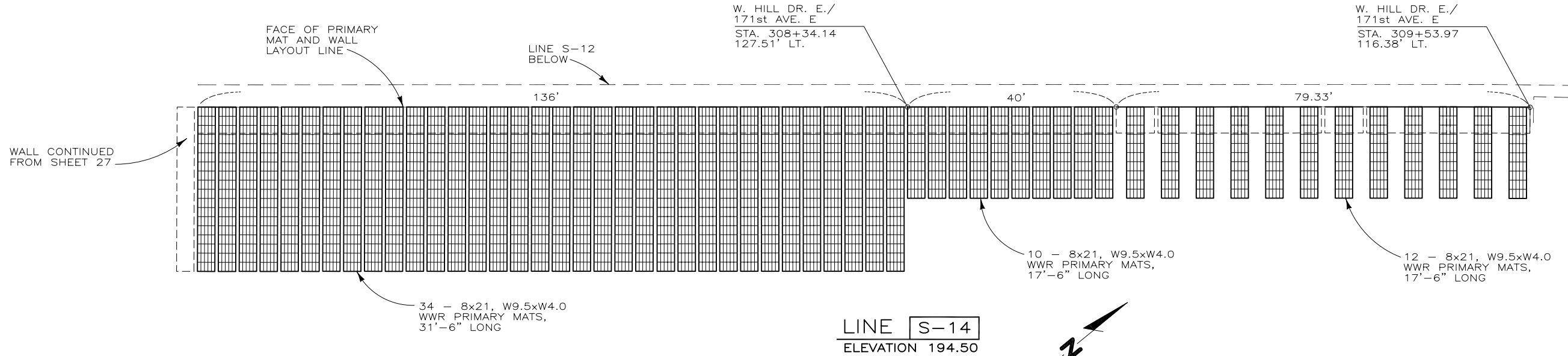

**NOTE:**  
ONLY MAJOR POINTS ALONG THE WALL LINES HAVE BEEN LOCATED.

050329AS PANORAMA WALL S

THIS DRAWING IS FURNISHED SOLELY FOR THE USE OF OR IN CONNECTION WITH THIS PROJECT, AND THE PROPRIETARY INFORMATION SHOWN HEREON IS NOT TO BE TRANSMITTED TO ANY OTHER ORGANIZATION WITHOUT SPECIFIC AUTHORIZATION BY THE HILFIKER COMPANY. HILFIKER RETAINING WALLS ARE PROTECTED BY ONE OR MORE OF THE FOLLOWING PATENTS: 3,631,682, 4,117,686, 4,260,296, 4,329,089, 4,324,508, 4,343,572, 4,391,557, 4,505,621, 4,616,959, 4,643,618, 4,661,023, 4,856,939, 5,733,072 AND OTHERS PENDING.

REV. NO.	DATE	BY	DESCRIPTION
1	08/11/05	DR	MINOR REVISIONS, ADDITIONS

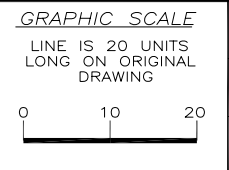

PROJ. MGR.  
WBH

ENGINEER

CADD BY  
DR

**HILFIKER RETAINING WALLS**  
3900 Broadway Eureka, CA 95503  
P.O. Box 2012 Eureka, CA 95501  
707-443-5093 Fax 707-443-2891  
Toll-Free 800-762-8962  
Web: <http://hilfiker.com> email: [info@hilfiker.com](mailto:info@hilfiker.com)



DWG DATE  
8 AUG 05

REVISION DATE  
11 AUG 05

SCALE  
NOTED

**SHOP DRAWING**

STEEPENED SLOPE  
**PANORAMA WEST SUBDIVISION**  
WALL S  
PIERCE COUNTY, WASHINGTON  
LINE S-14 AND S-15

PROJECT NO.  
050329AS

SHEET  
**28**  
OF 45

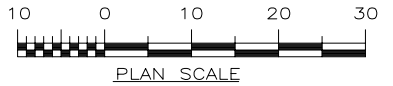
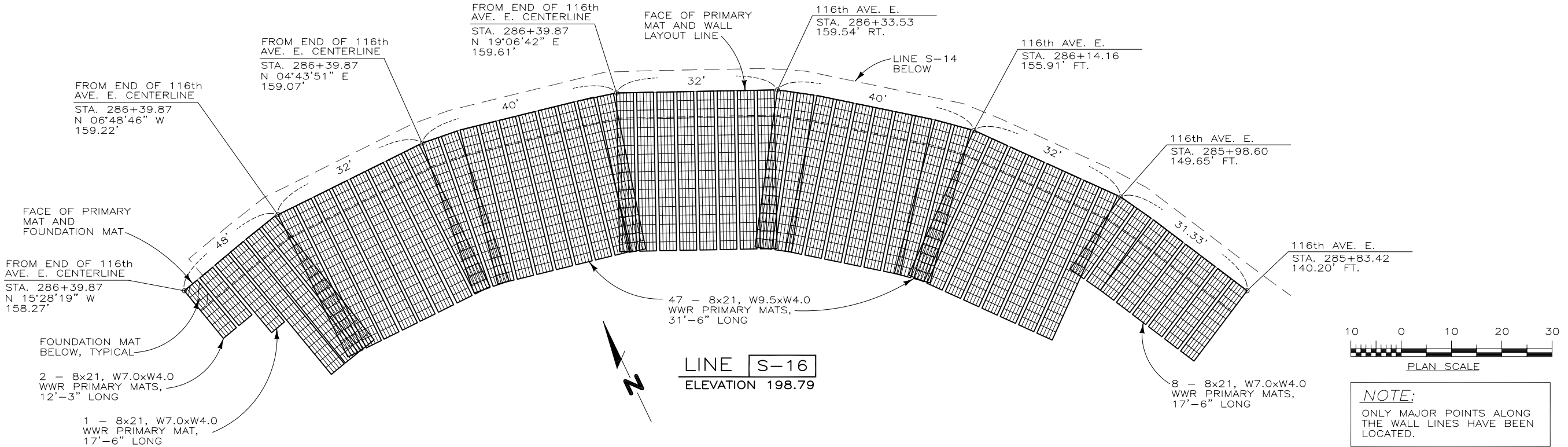

**NOTE:**  
ONLY MAJOR POINTS ALONG THE WALL LINES HAVE BEEN LOCATED.

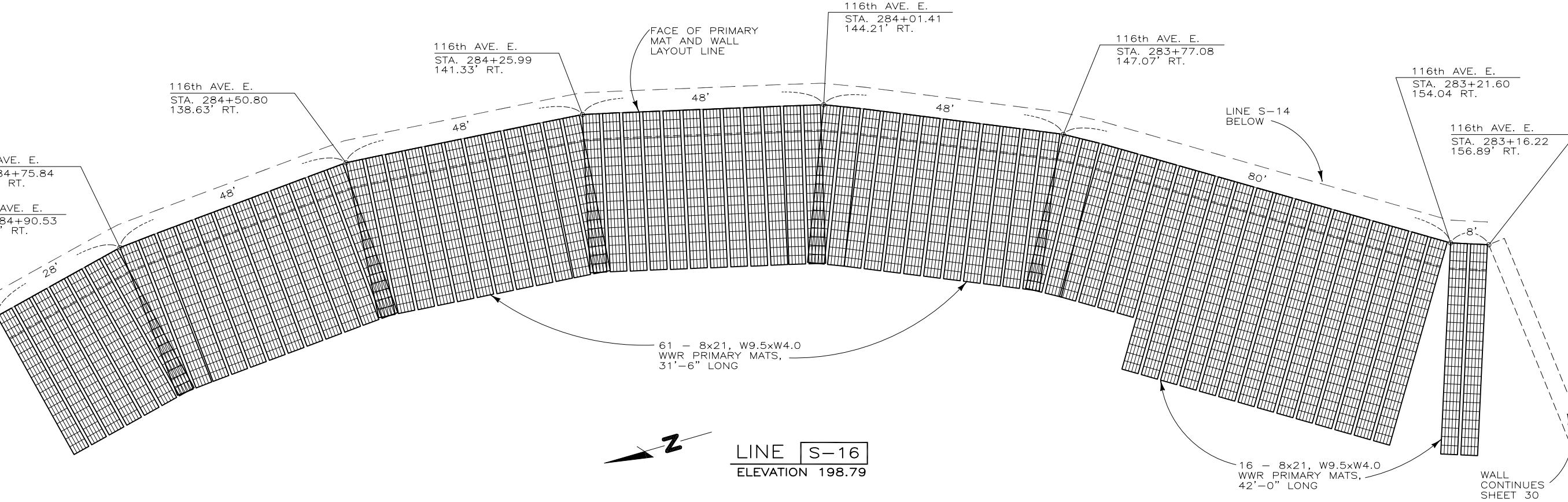

050329AS PANORAMA WALL S

THIS DRAWING IS FURNISHED SOLELY FOR THE USE OF OR IN CONNECTION WITH THIS PROJECT, AND THE PROPRIETARY INFORMATION SHOWN HEREON IS NOT TO BE TRANSMITTED TO ANY OTHER ORGANIZATION WITHOUT SPECIFIC AUTHORIZATION BY THE HILFIKER COMPANY. HILFIKER RETAINING WALLS ARE PROTECTED BY ONE OR MORE OF THE FOLLOWING PATENTS: 3,631,682, 4,117,686, 4,260,296, 4,329,089, 4,324,508, 4,343,572, 4,391,557, 4,505,621, 4,616,959, 4,643,618, 4,661,023, 4,856,939, 5,733,072 AND OTHERS PENDING.

REV. NO.	DATE	BY	DESCRIPTION
1	08/11/05	DR	MINOR REVISIONS, ADDITIONS

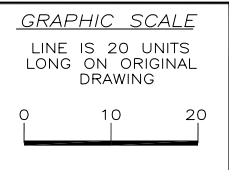

PROJ. MGR.  
WBH  
ENGINEER  
CADD BY  
DR

**HILFIKER RETAINING WALLS**  
3900 Broadway Eureka, CA 95503  
P.O. Box 2012 Eureka, CA 95501  
707-443-5093 Fax 707-443-2891  
Toll-Free 800-762-8962  
Web: <http://hilfiker.com> email: [info@hilfiker.com](mailto:info@hilfiker.com)

DWG DATE  
8 AUG 05  
REVISION DATE  
11 AUG 05  
SCALE  
NOTED

**SHOP DRAWING**  
STEEPENED SLOPE  
**PANORAMA WEST SUBDIVISION**  
WALL S  
PIERCE COUNTY, WASHINGTON  
LINE S-16

PROJECT NO.  
050329AS  
SHEET  
**29**  
OF 45



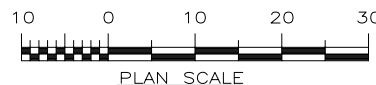
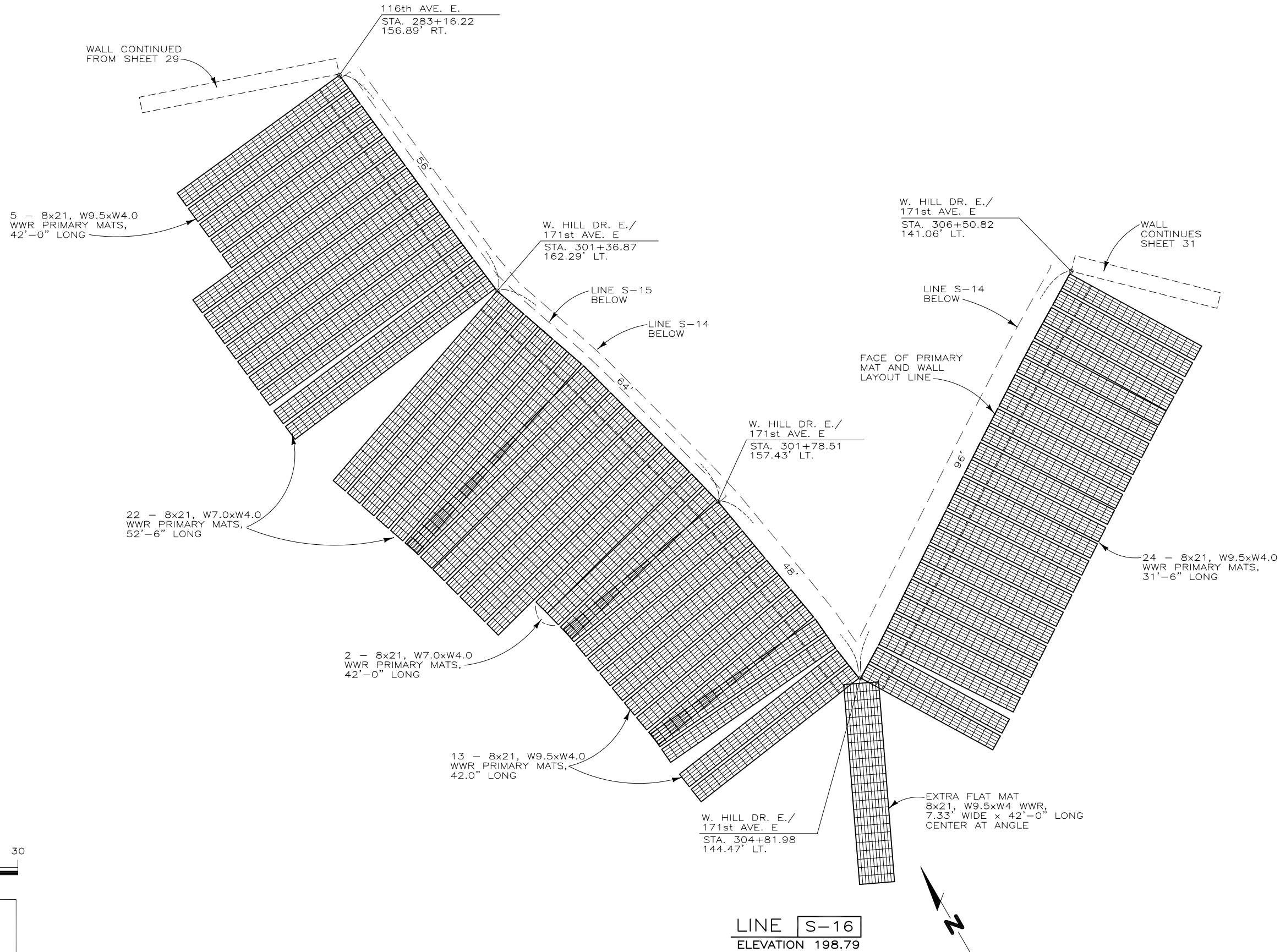

**NOTE:**  
ONLY MAJOR POINTS ALONG THE WALL LINES HAVE BEEN LOCATED.

**LINE S-16**  
ELEVATION 198.79

050329AS PANORAMA WALL S

THIS DRAWING IS FURNISHED SOLELY FOR THE USE OF OR IN CONNECTION WITH THIS PROJECT, AND THE PROPRIETARY INFORMATION SHOWN HEREON IS NOT TO BE TRANSMITTED TO ANY OTHER ORGANIZATION WITHOUT SPECIFIC AUTHORIZATION BY THE HILFIKER COMPANY. HILFIKER RETAINING WALLS ARE PROTECTED BY ONE OR MORE OF THE FOLLOWING PATENTS: 3,631,682, 4,117,686, 4,260,296, 4,329,089, 4,324,508, 4,343,572, 4,391,557, 4,505,621, 4,616,959, 4,643,618, 4,661,023, 4,856,939, 5,733,072 AND OTHERS PENDING.

REV. NO.	DATE	BY	DESCRIPTION
1	08/11/05	DR	MINOR REVISIONS, ADDITIONS

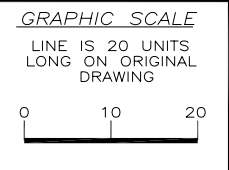

**PROJ. MGR.**  
WBH  
**ENGINEER**  
**CADD BY**  
DR

**HILFIKER RETAINING WALLS**  
3900 Broadway Eureka, CA 95503  
P.O. Box 2012 Eureka, CA 95501  
707-443-5093 Fax 707-443-2891  
Toll-Free 800-762-8962  
Web: <http://hilfiker.com> email: [info@hilfiker.com](mailto:info@hilfiker.com)

**DWG DATE**  
8 AUG 05  
**REVISION DATE**  
11 AUG 05  
**SCALE**  
NOTED

**SHOP DRAWING**  
STEEPENED SLOPE  
**PANORAMA WEST SUBDIVISION**  
WALL S  
PIERCE COUNTY, WASHINGTON  
LINE S-16

**PROJECT NO.**  
050329AS  
**SHEET**  
**30**  
OF 45

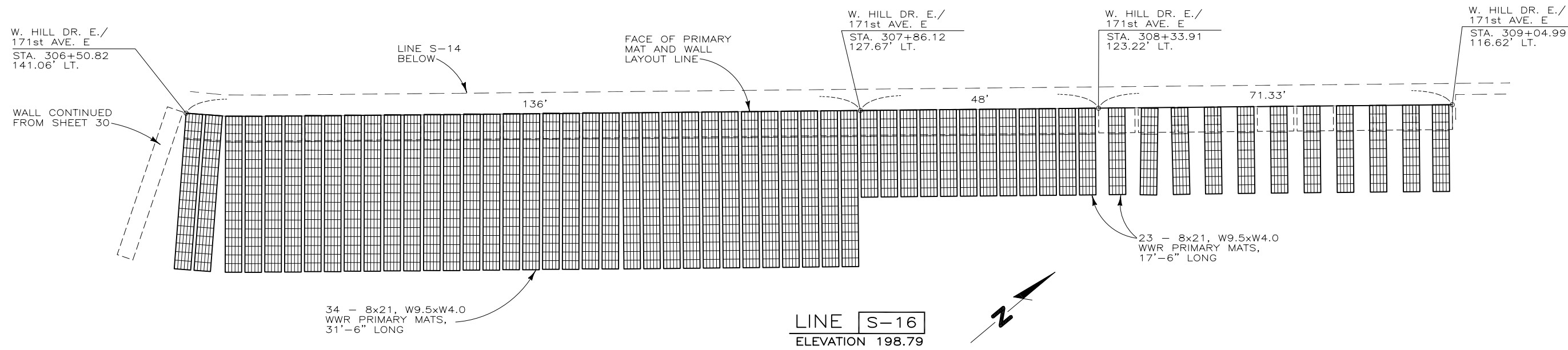

LINE S-16  
ELEVATION 198.79

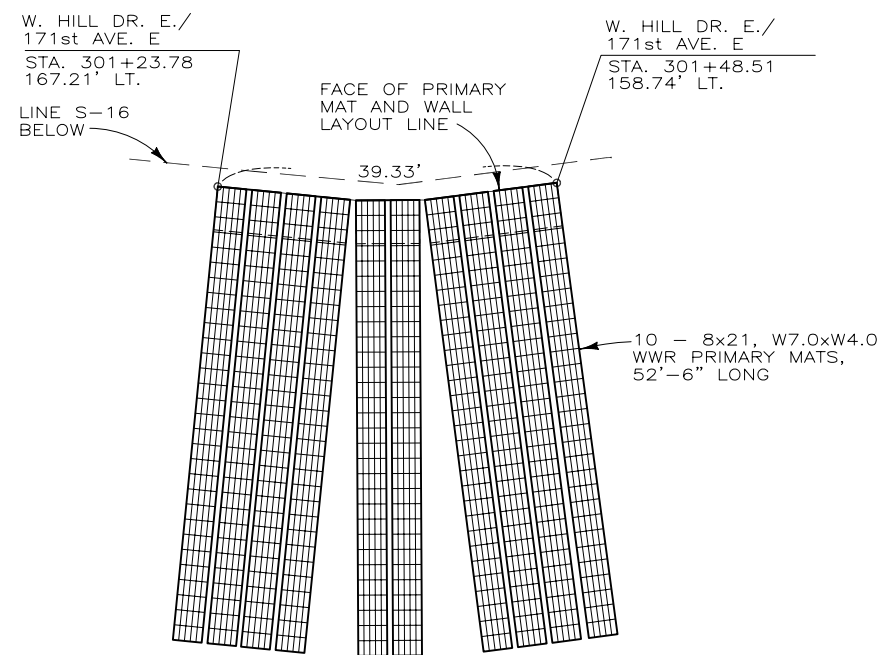

LINE S-17  
ELEVATION 200.94

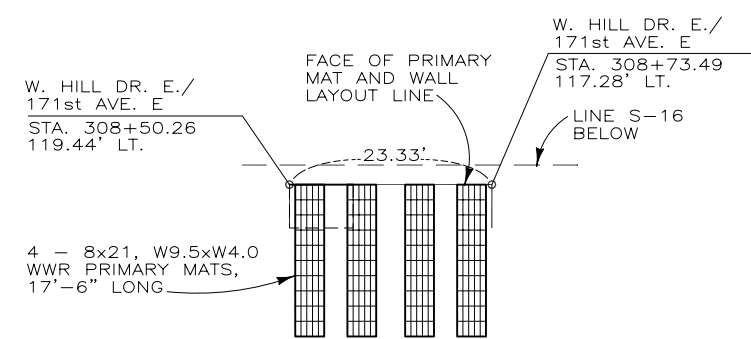

LINE S-17  
ELEVATION 200.94

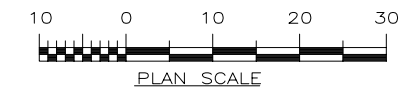

**NOTE:**  
ONLY MAJOR POINTS ALONG THE WALL LINES HAVE BEEN LOCATED.

050329AS PANORAMA WALL S

THIS DRAWING IS FURNISHED SOLELY FOR THE USE OF OR IN CONNECTION WITH THIS PROJECT, AND THE PROPRIETARY INFORMATION SHOWN HEREON IS NOT TO BE TRANSMITTED TO ANY OTHER ORGANIZATION WITHOUT SPECIFIC AUTHORIZATION BY THE HILFIKER COMPANY. HILFIKER RETAINING WALLS ARE PROTECTED BY ONE OR MORE OF THE FOLLOWING PATENTS: 3,631,682, 4,117,686, 4,260,296, 4,329,089, 4,324,508, 4,343,572, 4,391,557, 4,505,621, 4,616,959, 4,643,618, 4,661,023, 4,856,939, 5,733,072 AND OTHERS PENDING.

REV. NO.	DATE	BY	DESCRIPTION
1	08/11/05	DR	MINOR REVISIONS, ADDITIONS

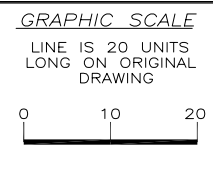

PROJ. MGR.  
WBH  
ENGINEER  
CADD BY  
DR

**HILFIKER RETAINING WALLS**  
3900 Broadway Eureka, CA 95503  
P.O. Box 2012 Eureka, CA 95501  
707-443-5093 Fax 707-443-2891  
Toll-Free 800-762-8962  
Web: <http://hilfiker.com> email: [info@hilfiker.com](mailto:info@hilfiker.com)



DWG DATE  
8 AUG 05  
REVISION DATE  
11 AUG 05  
SCALE  
NOTED

**SHOP DRAWING**  
STEEPENED SLOPE  
**PANORAMA WEST SUBDIVISION**  
WALL S  
PIERCE COUNTY, WASHINGTON  
LINE S-16 AND S-17

PROJECT NO.  
050329AS  
SHEET  
**31**  
OF 45

050329AS PANORAMA WALL S

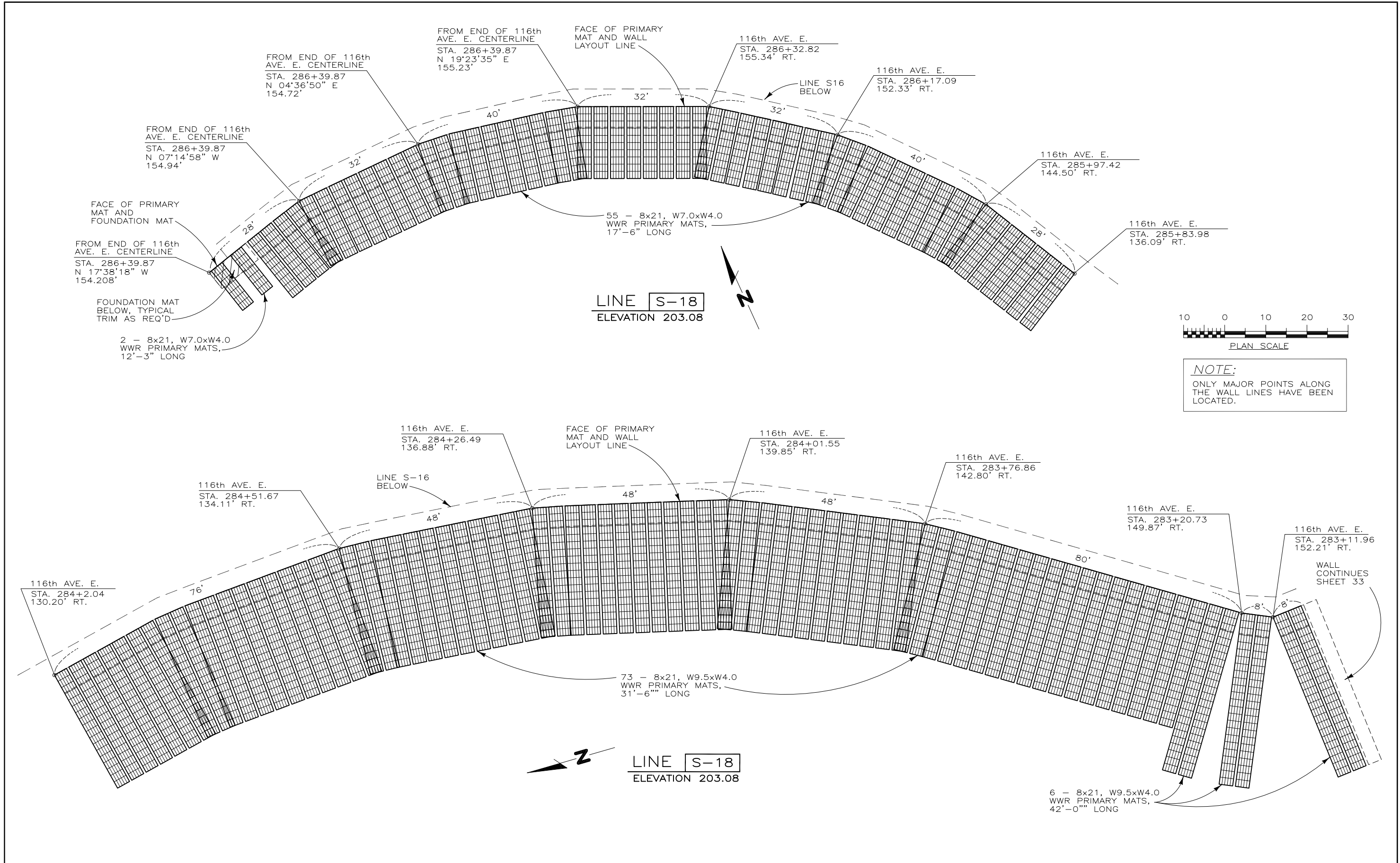

THIS DRAWING IS FURNISHED SOLELY FOR THE USE OF OR IN CONNECTION WITH THIS PROJECT, AND THE PROPRIETARY INFORMATION SHOWN HEREON IS NOT TO BE TRANSMITTED TO ANY OTHER ORGANIZATION WITHOUT SPECIFIC AUTHORIZATION BY THE HILFIKER COMPANY. HILFIKER RETAINING WALLS ARE PROTECTED BY ONE OR MORE OF THE FOLLOWING PATENTS: 3,631,682, 4,117,686, 4,260,296, 4,329,089, 4,324,508, 4,343,572, 4,391,557, 4,505,621, 4,616,959, 4,643,618, 4,661,023, 4,856,939, 5,733,072 AND OTHERS PENDING.

REV. NO.	DATE	BY	DESCRIPTION
1	08/11/05	DR	MINOR REVISIONS, ADDITIONS

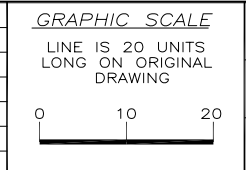

PROJ. MGR.  
WBH

ENGINEER

CADD BY  
DR

**HILFIKER RETAINING WALLS**  
3900 Broadway Eureka, CA 95503  
P.O. Box 2012 Eureka, CA 95501  
707-443-5093 Fax 707-443-2891  
Toll-Free 800-762-8962  
Web: <http://hilfiker.com> email: [info@hilfiker.com](mailto:info@hilfiker.com)

1902-2002  
**100 YEARS**  
HILFIKER COMPANY

DWG DATE  
8 AUG 05

REVISION DATE  
11 AUG 05

SCALE  
NOTED

**SHOP DRAWING**

STEEPENED SLOPE  
**PANORAMA WEST SUBDIVISION**  
WALL S  
PIERCE COUNTY, WASHINGTON

LINE S-18

PROJECT NO.  
050329AS

SHEET  
**32**  
OF 45



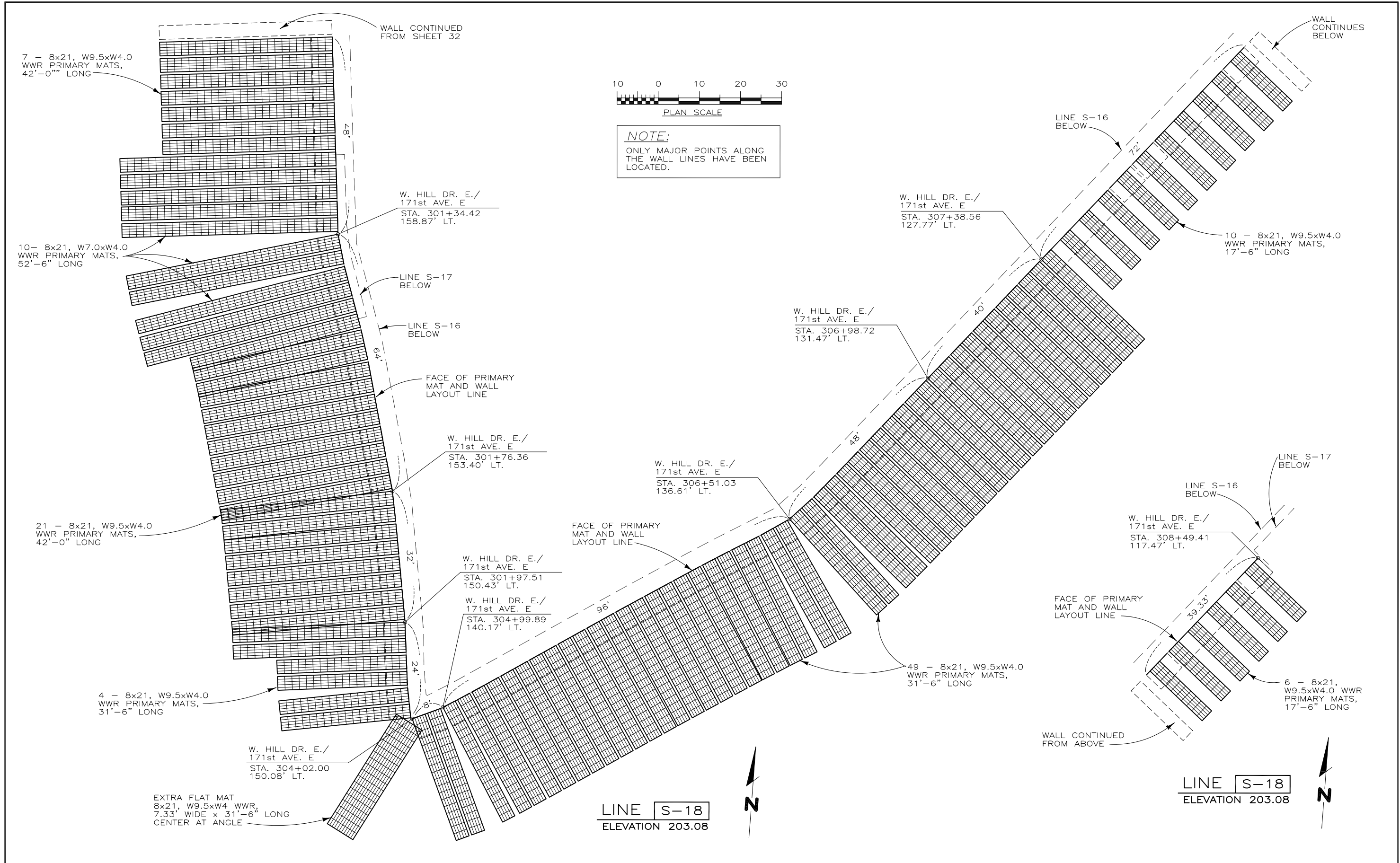

050329AS PANORAMA WALL S

THIS DRAWING IS FURNISHED SOLELY FOR THE USE OF OR IN CONNECTION WITH THIS PROJECT, AND THE PROPRIETARY INFORMATION SHOWN HEREON IS NOT TO BE TRANSMITTED TO ANY OTHER ORGANIZATION WITHOUT SPECIFIC AUTHORIZATION BY THE HILFIKER COMPANY. HILFIKER RETAINING WALLS ARE PROTECTED BY ONE OR MORE OF THE FOLLOWING PATENTS: 3,631,682, 4,117,686, 4,260,296, 4,329,089, 4,324,508, 4,343,572, 4,391,557, 4,505,621, 4,616,959, 4,643,618, 4,661,023, 4,856,939, 5,733,072 AND OTHERS PENDING.

REV. NO.	DATE	BY	DESCRIPTION
1	08/11/05	DR	MINOR REVISIONS, ADDITIONS

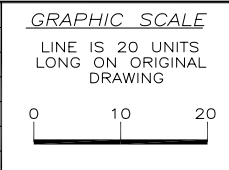

PROJ. MGR.  
WBH

ENGINEER

CADD BY  
DR

**HILFIKER RETAINING WALLS**  
3900 Broadway Eureka, CA 95501  
P.O. Box 2012 Eureka, CA 95501  
707-443-5093 Fax 707-443-2891  
Toll-Free 800-762-8962  
Web: <http://hilfiker.com> email: [info@hilfiker.com](mailto:info@hilfiker.com)

DWG DATE  
8 AUG 05

REVISION DATE  
11 AUG 05

SCALE  
NOTED

**SHOP DRAWING**

STEEPENED SLOPE  
**PANORAMA WEST SUBDIVISION**  
WALL S  
PIERCE COUNTY, WASHINGTON

LINE S-18

PROJECT NO.  
050329AS

SHEET  
**33**  
OF 45

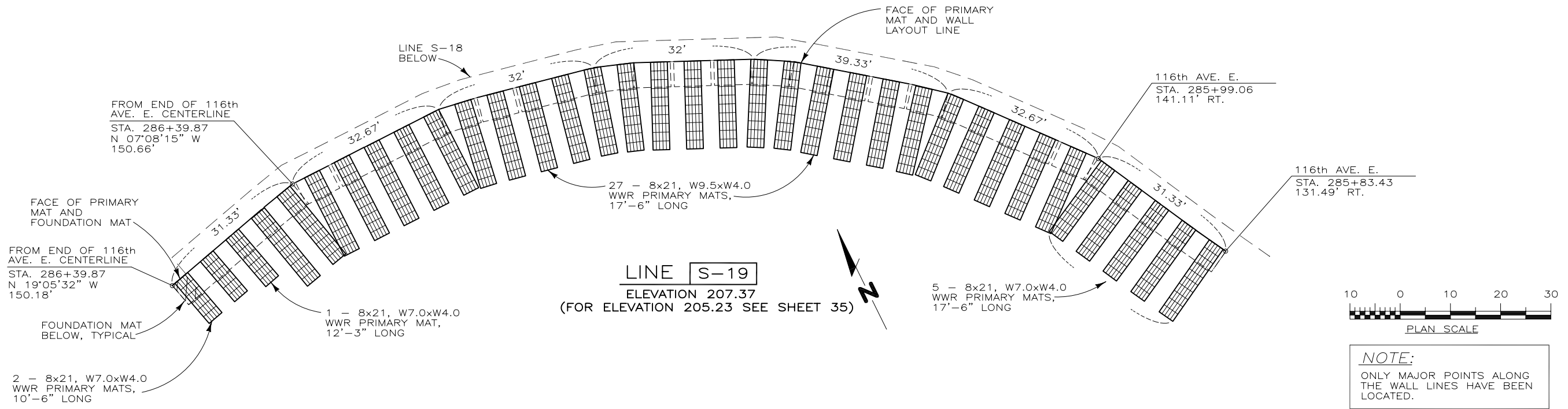

**NOTE:**  
ONLY MAJOR POINTS ALONG THE WALL LINES HAVE BEEN LOCATED.

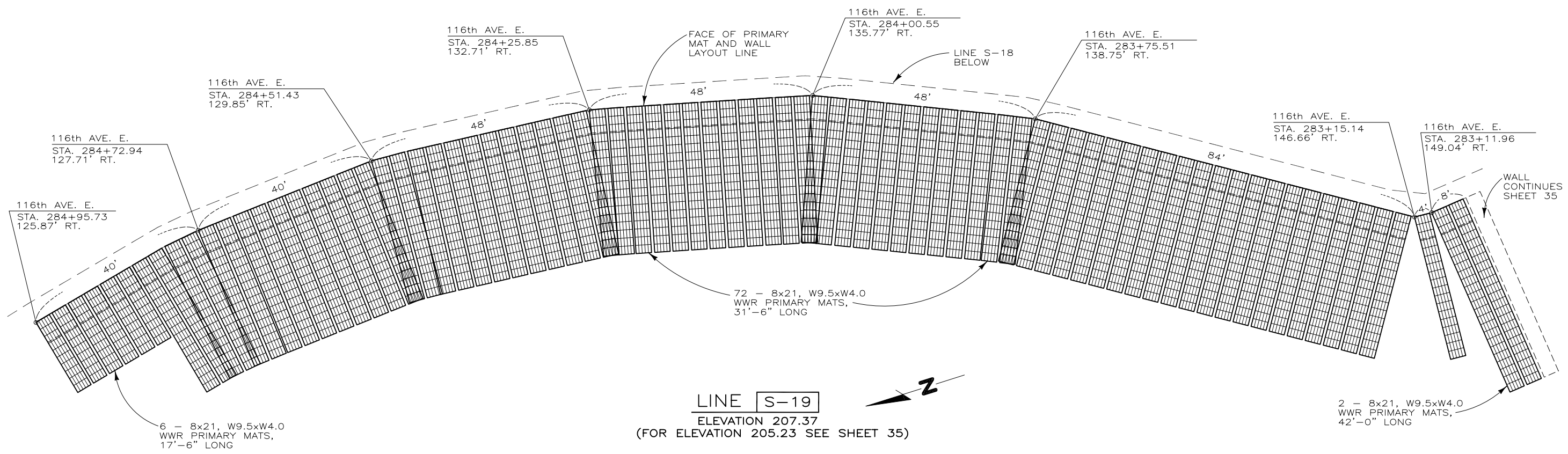

050329AS PANORAMA WALL S

THIS DRAWING IS FURNISHED SOLELY FOR THE USE OF OR IN CONNECTION WITH THIS PROJECT, AND THE PROPRIETARY INFORMATION SHOWN HEREON IS NOT TO BE TRANSMITTED TO ANY OTHER ORGANIZATION WITHOUT SPECIFIC AUTHORIZATION BY THE HILFIKER COMPANY. HILFIKER RETAINING WALLS ARE PROTECTED BY ONE OR MORE OF THE FOLLOWING PATENTS: 3,631,682; 4,117,686; 4,260,296; 4,329,089; 4,324,508; 4,343,572; 4,391,557; 4,505,621; 4,516,959; 4,643,618; 4,661,023; 4,896,839; 5,733,072 AND OTHERS PENDING.

REV.NO.	DATE	BY	DESCRIPTION

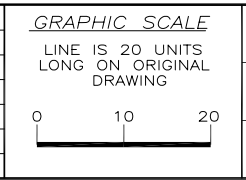

PROJ. MGR.  
WBH  
ENGINEER  
CADD BY  
DR

**HILFIKER RETAINING WALLS**  
3900 Broadway Eureka, CA 95503  
P.O. Box 2012 Eureka, CA 95501  
707-443-5093 Fax 707-443-2891  
Toll-Free 800-762-8962  
Web: <http://hilfiker.com> email: [info@hilfiker.com](mailto:info@hilfiker.com)

DWG DATE  
11 AUG 05  
REVISION DATE  
SCALE  
NOTED

**SHOP DRAWING**  
STEEPENED SLOPE  
**PANORAMA WEST SUBDIVISION**  
WALL S  
PIERCE COUNTY, WASHINGTON  
LINE S-19

PROJECT NO.  
050329AS  
SHEET  
**34**  
OF 45

WALL CONTINUED FROM SHEET 34

WALL CONTINUES BELOW



**NOTE:**  
ONLY MAJOR POINTS ALONG THE WALL LINES HAVE BEEN LOCATED.

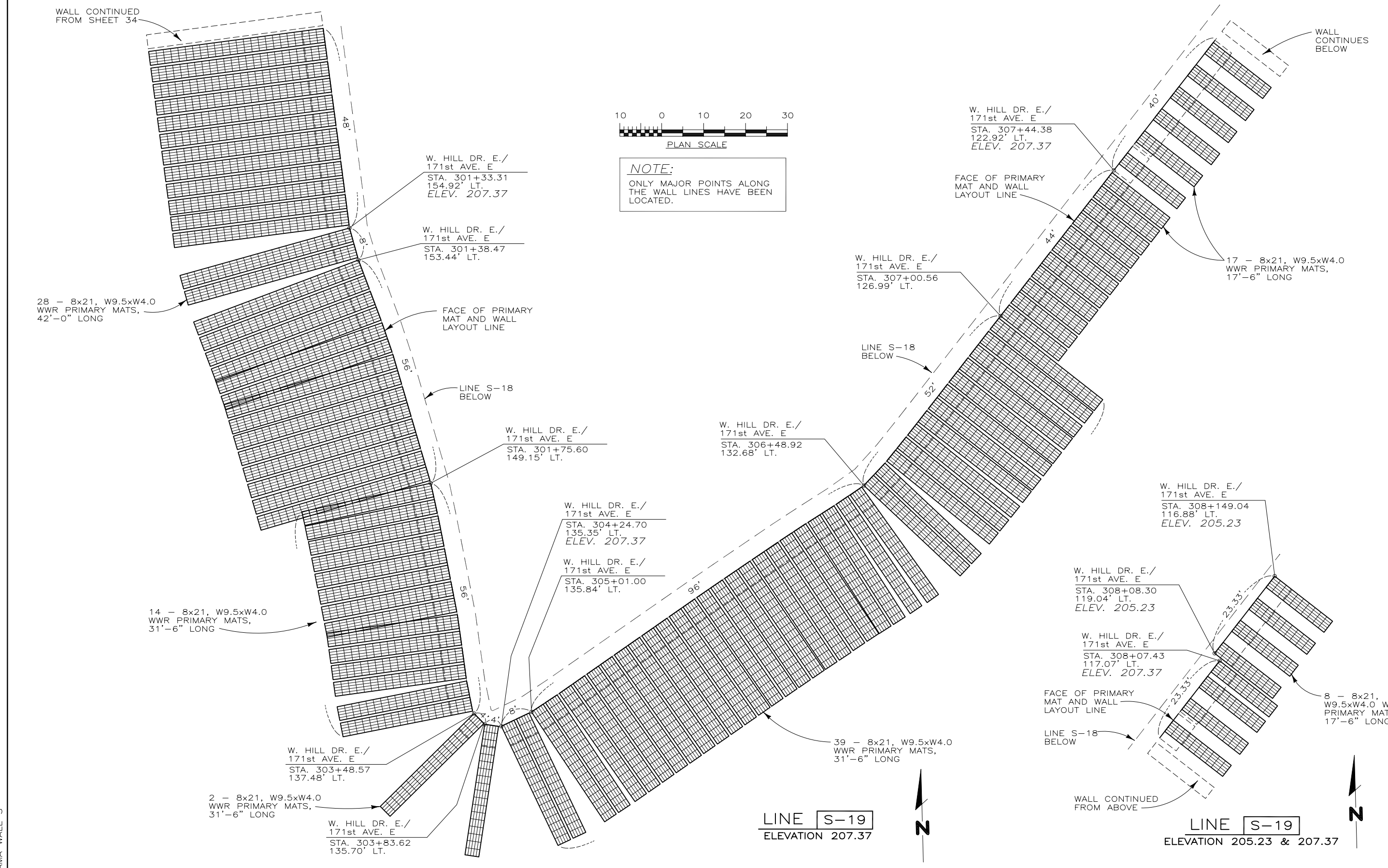

050329AS PANORAMA WALL S

THIS DRAWING IS FURNISHED SOLELY FOR THE USE OF OR IN CONNECTION WITH THIS PROJECT, AND THE PROPRIETARY INFORMATION SHOWN HEREON IS NOT TO BE TRANSMITTED TO ANY OTHER ORGANIZATION WITHOUT SPECIFIC AUTHORIZATION BY THE HILFIKER COMPANY. HILFIKER RETAINING WALLS ARE PROTECTED BY ONE OR MORE OF THE FOLLOWING PATENTS: 3,631,682, 4,117,686, 4,260,296, 4,329,089, 4,324,508, 4,343,572, 4,391,557, 4,505,621, 4,616,959, 4,643,618, 4,661,023, 4,856,939, 5,733,072 AND OTHERS PENDING.

REV. NO.	DATE	BY	DESCRIPTION

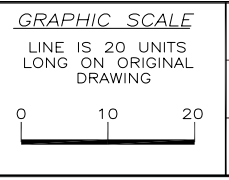

PROJ. MGR.  
WBH  
ENGINEER  
CADD BY  
DR

**HILFIKER RETAINING WALLS**  
3900 Broadway Eureka, CA 95503  
P.O. Box 2012 Eureka, CA 95501  
707-443-5093 Fax 707-443-2891  
Toll-Free 800-762-8962  
Web: <http://hilfiker.com> email: [info@hilfiker.com](mailto:info@hilfiker.com)



DWG DATE  
11 AUG 05  
REVISION DATE  
SCALE  
NOTED

**SHOP DRAWING**  
STEEPENED SLOPE  
**PANORAMA WEST SUBDIVISION**  
WALL S  
PIERCE COUNTY, WASHINGTON  
LINE S-19

PROJECT NO.  
050329AS  
SHEET  
**35**  
OF 45

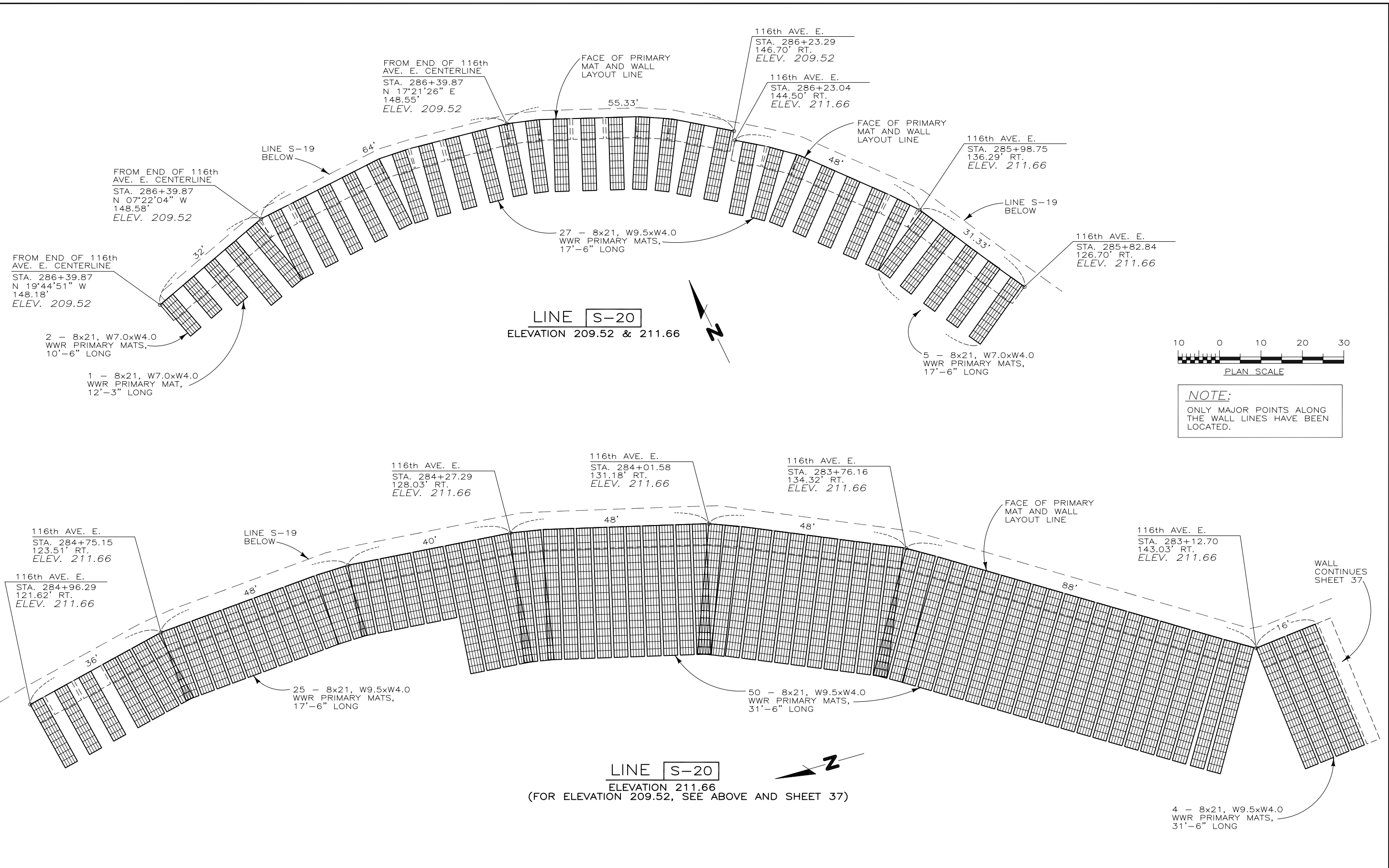

**NOTE:**  
ONLY MAJOR POINTS ALONG THE WALL LINES HAVE BEEN LOCATED.

050329AS PANORAMA WALL S

THIS DRAWING IS FURNISHED SOLELY FOR THE USE OF OR IN CONNECTION WITH THIS PROJECT, AND THE PROPRIETARY INFORMATION SHOWN HEREON IS NOT TO BE TRANSMITTED TO ANY OTHER ORGANIZATION WITHOUT SPECIFIC AUTHORIZATION BY THE HILFIKER COMPANY. HILFIKER RETAINING WALLS ARE PROTECTED BY ONE OR MORE OF THE FOLLOWING PATENTS: 3,631,682, 4,117,686, 4,260,296, 4,329,089, 4,324,508, 4,343,572, 4,391,557, 4,505,621, 4,616,959, 4,643,618, 4,661,023, 4,856,939, 5,733,072 AND OTHERS PENDING.	REV.NO.	DATE	BY	DESCRIPTION	<b>GRAPHIC SCALE</b> LINE IS 20 UNITS LONG ON ORIGINAL DRAWING 	PROJ.MGR. WBH	<b>HILFIKER RETAINING WALLS</b> 3900 Broadway Eureka, CA 95503 P.O. Box 2012 Eureka, CA 95501 707-443-5093 Fax 707-443-2891 Toll-Free 800-762-8962 Web: <a href="http://hilfiker.com">http://hilfiker.com</a> email: <a href="mailto:info@hilfiker.com">info@hilfiker.com</a>	DWG DATE 11 AUG 05	<b>SHOP DRAWING</b> STEEPENED SLOPE <b>PANORAMA WEST SUBDIVISION</b> WALL S PIERCE COUNTY, WASHINGTON LINE S-20	PROJECT NO. 050329AS
						ENGINEER		REVISION DATE		SHEET <b>36</b>
						CADD BY DR		SCALE NOTED		OF 45



050329AS PANORAMA WALL S

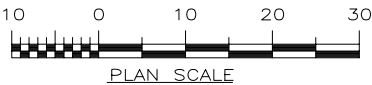
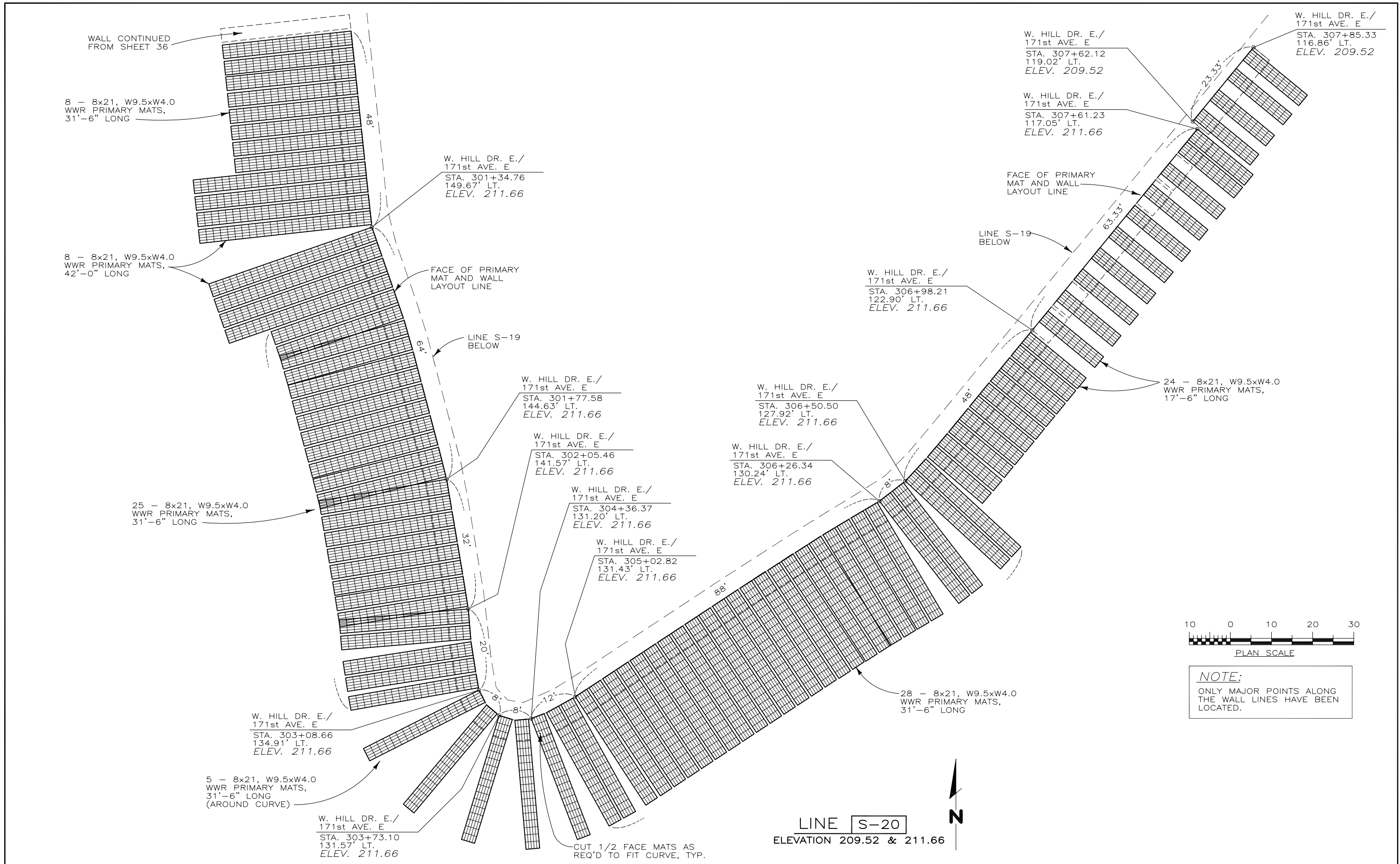

**NOTE:**  
ONLY MAJOR POINTS ALONG THE WALL LINES HAVE BEEN LOCATED.

**LINE S-20**  
ELEVATION 209.52 & 211.66



THIS DRAWING IS FURNISHED SOLELY FOR THE USE OF OR IN CONNECTION WITH THIS PROJECT, AND THE PROPRIETARY INFORMATION SHOWN HEREON IS NOT TO BE TRANSMITTED TO ANY OTHER ORGANIZATION WITHOUT SPECIFIC AUTHORIZATION BY THE HILFIKER COMPANY. HILFIKER RETAINING WALLS ARE PROTECTED BY ONE OR MORE OF THE FOLLOWING PATENTS: 3,631,682, 4,117,686, 4,260,296, 4,329,089, 4,324,508, 4,343,572, 4,391,557, 4,505,621, 4,616,959, 4,643,618, 4,661,023, 4,856,939, 5,733,072 AND OTHERS PENDING.

REV. NO.	DATE	BY	DESCRIPTION

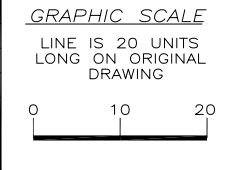

PROJ. MGR.  
WBH  
ENGINEER  
CADD BY  
DR

**HILFIKER RETAINING WALLS**  
3900 Broadway Eureka, CA 95503  
P.O. Box 2012 Eureka, CA 95501  
707-443-5093 Fax 707-443-2891  
Toll-Free 800-762-8962  
Web: <http://hilfiker.com> email: [info@hilfiker.com](mailto:info@hilfiker.com)

DWG DATE  
11 AUG 05  
REVISION DATE  
SCALE  
NOTED

**SHOP DRAWING**  
STEEPENED SLOPE  
**PANORAMA WEST SUBDIVISION**  
WALL S  
PIERCE COUNTY, WASHINGTON  
LINE S-20

PROJECT NO.  
050329AS  
SHEET  
**37**  
OF 45



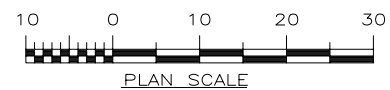
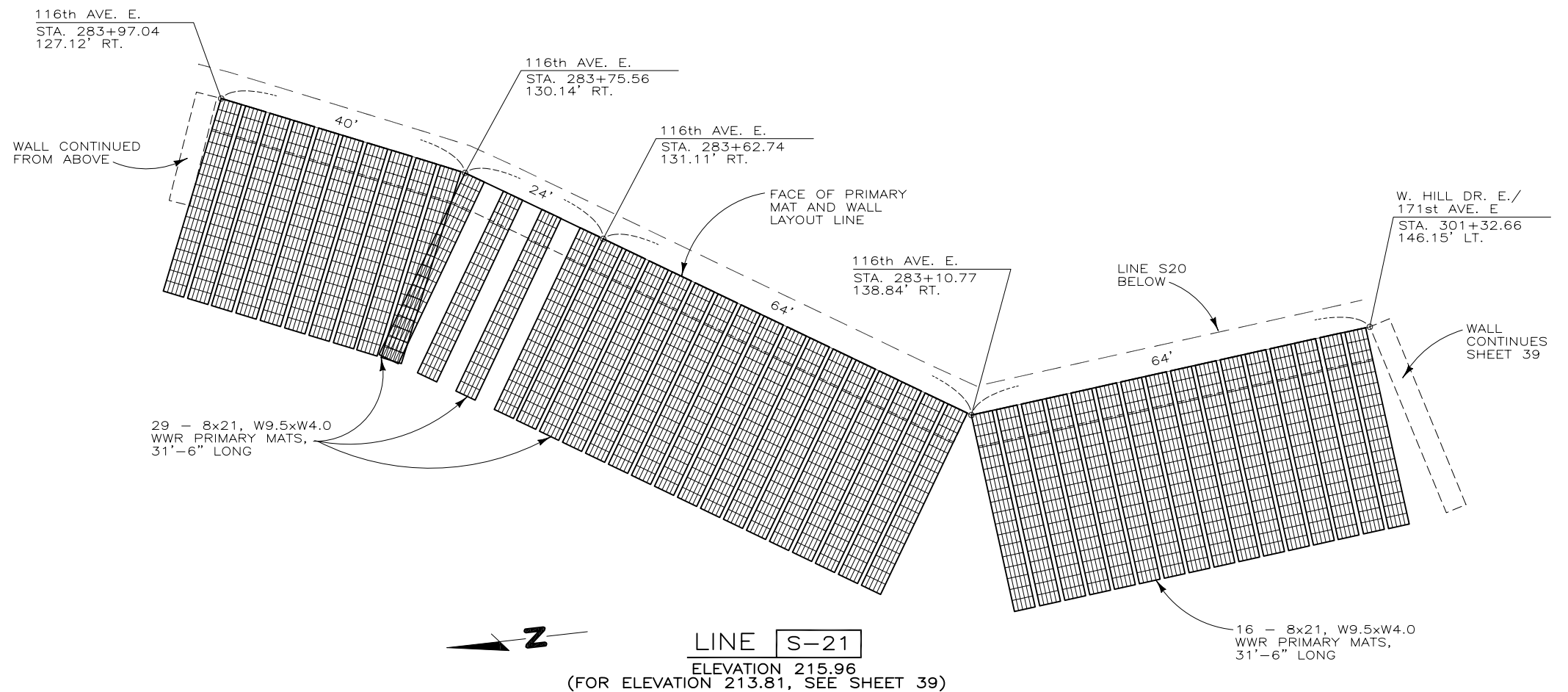
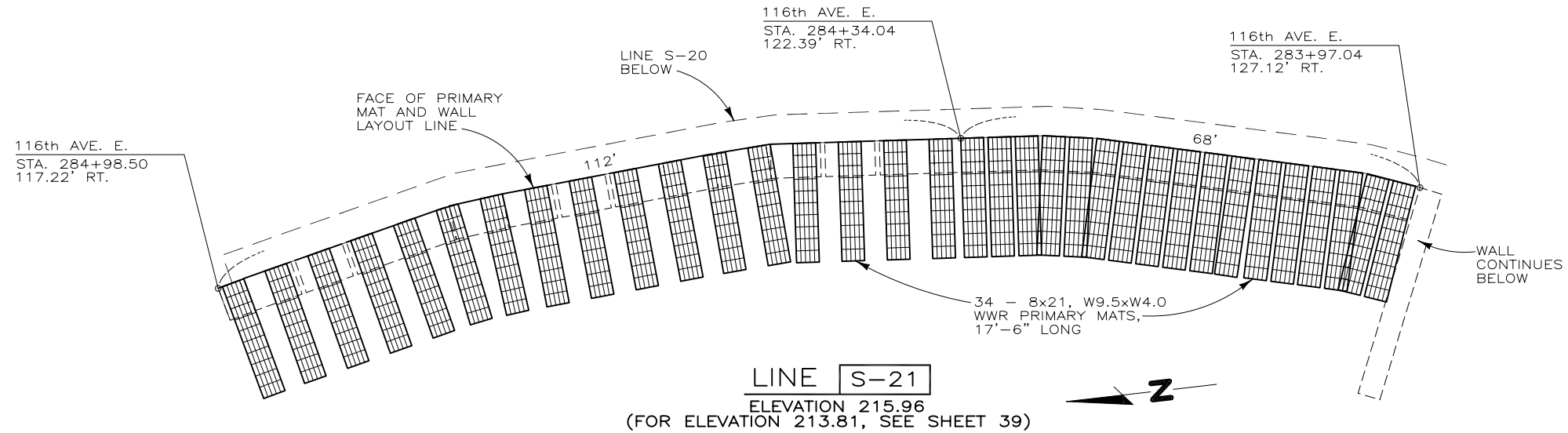

**NOTE:**  
ONLY MAJOR POINTS ALONG THE WALL LINES HAVE BEEN LOCATED.

050329AS PANORAMA WALL S

THIS DRAWING IS FURNISHED SOLELY FOR THE USE OF OR IN CONNECTION WITH THIS PROJECT, AND THE PROPRIETARY INFORMATION SHOWN HEREON IS NOT TO BE TRANSMITTED TO ANY OTHER ORGANIZATION WITHOUT SPECIFIC AUTHORIZATION BY THE HILFIKER COMPANY. HILFIKER RETAINING WALLS ARE PROTECTED BY ONE OR MORE OF THE FOLLOWING PATENTS: 3,631,682, 4,117,686, 4,260,296, 4,329,089, 4,324,508, 4,343,572, 4,391,557, 4,505,621, 4,616,959, 4,643,618, 4,661,023, 4,856,939, 5,733,072 AND OTHERS PENDING.

REV. NO.	DATE	BY	DESCRIPTION

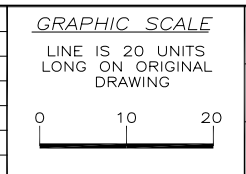

PROJ. MGR.  
WBH  
ENGINEER  
CADD BY  
DR

**HILFIKER RETAINING WALLS**  
3900 Broadway Eureka, CA 95503  
P.O. Box 2012 Eureka, CA 95501  
707-443-5093 Fax 707-443-2891  
Toll-Free 800-762-8962  
Web: <http://hilfiker.com> email: [info@hilfiker.com](mailto:info@hilfiker.com)

DWG DATE  
11 AUG 05  
REVISION DATE  
SCALE  
NOTED

**SHOP DRAWING**  
STEEPENED SLOPE  
**PANORAMA WEST SUBDIVISION**  
WALL S  
PIERCE COUNTY, WASHINGTON  
LINE S-21

PROJECT NO.  
050329AS  
SHEET  
**38**  
OF 45

WALL CONTINUED FROM SHEET 38

W. HILL DR. E./ 171st AVE. E.  
STA. 301+32.66  
146.15' LT.  
ELEV. 215.96

FACE OF PRIMARY MAT AND WALL LAYOUT LINE

LINE S-20 BELOW

30 - 8x21, W9.5xW4.0 WWR PRIMARY MATS, 31'-6" LONG

W. HILL DR. E./ 171st AVE. E.  
STA. 301+97.57  
137.53' LT.  
ELEV. 215.96

W. HILL DR. E./ 171st AVE. E.  
STA. 302+99.83  
130.53' LT.  
ELEV. 215.96

W. HILL DR. E./ 171st AVE. E.  
STA. 305+08.23  
127.18' LT.  
ELEV. 215.96

W. HILL DR. E./ 171st AVE. E.  
STA. 306+46.24  
124.49' LT.  
ELEV. 215.96

W. HILL DR. E./ 171st AVE. E.  
STA. 305+72.19  
127.30' LT.  
ELEV. 215.96

W. HILL DR. E./ 171st AVE. E.  
STA. 307+18.84  
120.04' LT.  
ELEV. 213.81

W. HILL DR. E./ 171st AVE. E.  
STA. 307+17.09  
116.60' LT.  
ELEV. 215.96

W. HILL DR. E./ 171st AVE. E.  
STA. 307+41.20  
116.65' LT.  
ELEV. 213.81

FACE OF PRIMARY MAT AND WALL LAYOUT LINE

LINE S-20 BELOW

4 - 8x21, W9.5xW4.0 WWR PRIMARY MATS, 17'-6" LONG

10 - 8x21, W9.5xW4.0 WWR PRIMARY MATS, 17'-6" LONG

8 - 8x21, W9.5xW4.0 WWR PRIMARY MATS, 17'-6" LONG

4 - 8x21, W9.5xW4.0 WWR PRIMARY MATS, 31'-6" LONG (AROUND CURVE)

12 - 8x21, W9.5xW4.0 WWR PRIMARY MATS, 31'-6" LONG

W. HILL DR. E./ 171st AVE. E.  
STA. 303+79.44  
127.04' LT.  
ELEV. 215.96

W. HILL DR. E./ 171st AVE. E.  
STA. 304+56.69  
127.23' LT.  
ELEV. 215.96

LINE S-21  
ELEVATION 213.81 AND 215.96



**NOTE:**  
ONLY MAJOR POINTS ALONG THE WALL LINES HAVE BEEN LOCATED.



050329AS PANORAMA WALL S

THIS DRAWING IS FURNISHED SOLELY FOR THE USE OF OR IN CONNECTION WITH THIS PROJECT, AND THE PROPRIETARY INFORMATION SHOWN HEREON IS NOT TO BE TRANSMITTED TO ANY OTHER ORGANIZATION WITHOUT SPECIFIC AUTHORIZATION BY THE HILFIKER COMPANY. HILFIKER RETAINING WALLS ARE PROTECTED BY ONE OR MORE OF THE FOLLOWING PATENTS: 3,631,682, 4,117,686, 4,260,296, 4,329,093, 4,324,508, 4,343,572, 4,391,557, 4,505,821, 4,616,959, 4,643,618, 4,661,023, 4,856,359, 5,733,072 AND OTHERS PENDING.

REV. NO.	DATE	BY	DESCRIPTION

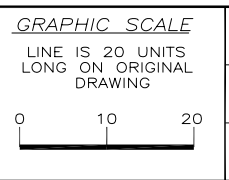

PROJ. MGR.  
WBH  
ENGINEER  
CADD BY  
DR

**HILFIKER RETAINING WALLS**  
3900 Broadway Eureka, CA 95503  
P.O. Box 2012 Eureka, CA 95501  
707-443-5093 Fax 707-443-2891  
Toll-Free 800-762-8962  
Web: <http://hilfiker.com> email: [info@hilfiker.com](mailto:info@hilfiker.com)

DWG DATE  
11 AUG 05  
REVISION DATE  
SCALE  
NOTED

**SHOP DRAWING**  
STEEPENED SLOPE  
**PANORAMA WEST SUBDIVISION**  
WALL S  
PIERCE COUNTY, WASHINGTON  
LINE S-21

PROJECT NO.  
050329AS  
SHEET  
**39**  
OF 45

116th AVE. E.  
STA. 284+81.52  
116.00' RT.  
ELEV. 218.10

116th AVE. E.  
STA. 284+55.00  
118.32' RT.  
ELEV. 218.10

116th AVE. E.  
STA. 284+54.51  
116.25' RT.  
ELEV. 220.25

116th AVE. E.  
STA. 283+74.96  
125.88' RT.  
ELEV. 220.25

116th AVE. E.  
STA. 283+61.83  
126.93' RT.  
ELEV. 220.25

116th AVE. E.  
STA. 283+28.32  
131.12' RT.  
ELEV. 220.25

116th AVE. E.  
STA. 283+08.94  
134.80' RT.  
ELEV. 220.25

47.33'  
8 - 8x21, W9.5xW4.0  
WWR PRIMARY MATS,  
17'-6" LONG

96'  
29 - 8x21, W9.5xW4.0  
WWR PRIMARY MATS,  
17'-6" LONG

24'  
40'  
24'  
40'  
22 - 8x21, W9.5xW4.0  
WWR PRIMARY MATS,  
31'-6" LONG

LINE S-21  
BELOW

FACE OF PRIMARY  
MAT AND WALL  
LAYOUT LINE

WALL  
CONTINUES  
SHEET 41



LINE S-22  
ELEVATION 218.10 AND 220.25

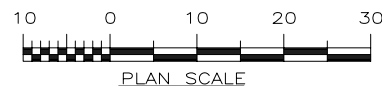

**NOTE:**

ONLY MAJOR POINTS ALONG  
THE WALL LINES HAVE BEEN  
LOCATED.

050329AS PANORAMA WALL S

THIS DRAWING IS FURNISHED SOLELY FOR THE USE OF OR IN CONNECTION WITH THIS PROJECT, AND THE PROPRIETARY INFORMATION SHOWN HEREON IS NOT TO BE TRANSMITTED TO ANY OTHER ORGANIZATION WITHOUT SPECIFIC AUTHORIZATION BY THE HILFIKER COMPANY. HILFIKER RETAINING WALLS ARE PROTECTED BY ONE OR MORE OF THE FOLLOWING PATENTS: 3,631,682, 4,117,686, 4,260,296, 4,329,089, 4,324,808, 4,343,572, 4,391,557, 4,505,621, 4,616,959, 4,643,618, 4,661,023, 4,856,939, 5,733,072 AND OTHERS PENDING.

REV. NO.	DATE	BY	DESCRIPTION

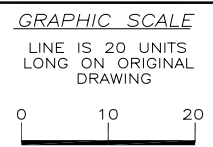

PROJ. MGR.  
WBH  
ENGINEER  
CADD BY  
DR

**HILFIKER RETAINING WALLS**  
3900 Broadway Eureka, CA 95503  
P.O. Box 2012 Eureka, CA 95501  
707-443-5093 Fax 707-443-2891  
Toll-Free 800-762-8962  
Web: <http://hilfiker.com> email: [info@hilfiker.com](mailto:info@hilfiker.com)

DWG DATE  
11 AUG 05  
REVISION DATE  
SCALE  
NOTED

**SHOP DRAWING**  
STEEPENED SLOPE  
**PANORAMA WEST SUBDIVISION**  
WALL S  
PIERCE COUNTY, WASHINGTON  
LINE S-22

PROJECT NO.  
050329AS  
SHEET  
**40**  
OF 45



WALL CONTINUED FROM SHEET 40

W. HILL DR. E./  
171st AVE. E.  
STA. 301+30.52  
142.73' LT.  
ELEV. 220.25

W. HILL DR. E./  
171st AVE. E.  
STA. 301+35.77  
140.89' LT.  
ELEV. 220.25

W. HILL DR. E./  
171st AVE. E.  
STA. 306+97.04  
116.44' LT.  
ELEV. 218.10

W. HILL DR. E./  
171st AVE. E.  
STA. 306+73.82  
118.61' LT.  
ELEV. 218.10

W. HILL DR. E./  
171st AVE. E.  
STA. 306+72.97  
116.63' LT.  
ELEV. 220.25

W. HILL DR. E./  
171st AVE. E.  
STA. 306+27.90  
121.07' LT.  
ELEV. 220.25

W. HILL DR. E./  
171st AVE. E.  
STA. 301+90.41  
133.99' LT.  
ELEV. 220.25

W. HILL DR. E./  
171st AVE. E.  
STA. 302+69.80  
127.73' LT.  
ELEV. 220.25

W. HILL DR. E./  
171st AVE. E.  
STA. 304+49.84  
122.82' LT.  
ELEV. 220.25

W. HILL DR. E./  
171st AVE. E.  
STA. 305+05.57  
122.82' LT.  
ELEV. 220.25

W. HILL DR. E./  
171st AVE. E.  
STA. 303+61.86  
123.15' LT.  
ELEV. 220.25

35 - 8x21, W9.5xW4.0  
WWR PRIMARY MATS,  
31'-6" LONG

29 - 8x21, W9.5xW4.0  
WWR PRIMARY MATS,  
17'-6" LONG

FACE OF PRIMARY  
MAT AND WALL  
LAYOUT LINE

FACE OF PRIMARY  
MAT AND WALL  
LAYOUT LINE

LINE S-21  
BELOW

LINE S-21  
BELOW

LINE S-22  
ELEVATION 218.10 AND 220.25



**NOTE:**

ONLY MAJOR POINTS ALONG  
THE WALL LINES HAVE BEEN  
LOCATED.

050329AS PANORAMA WALL S

THIS DRAWING IS FURNISHED SOLELY FOR THE USE OF OR IN CONNECTION WITH THIS PROJECT, AND THE PROPRIETARY INFORMATION SHOWN HEREON IS NOT TO BE TRANSMITTED TO ANY OTHER ORGANIZATION WITHOUT SPECIFIC AUTHORIZATION BY THE HILFIKER COMPANY. HILFIKER RETAINING WALLS ARE PROTECTED BY ONE OR MORE OF THE FOLLOWING PATENTS: 3,631,682, 4,117,686, 4,260,296, 4,329,089, 4,324,508, 4,343,572, 4,391,557, 4,505,621, 4,616,959, 4,643,618, 4,661,023, 4,856,939, 5,733,072 AND OTHERS PENDING.

REV. NO.	DATE	BY	DESCRIPTION

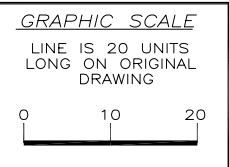

PROJ. MGR.  
WBH  
ENGINEER  
CADD BY  
DR

**HILFIKER RETAINING WALLS**  
3900 Broadway Eureka, CA 95503  
P.O. Box 2012 Eureka, CA 95501  
707-443-5093 Fax 707-443-2891  
Toll-Free 800-762-8962  
Web: <http://hilfiker.com> email: [info@hilfiker.com](mailto:info@hilfiker.com)



DWG DATE  
11 AUG 05  
REVISION DATE  
SCALE  
NOTED

**SHOP DRAWING**  
STEEPENED SLOPE  
**PANORAMA WEST SUBDIVISION**  
WALL S  
PIERCE COUNTY, WASHINGTON  
LINE S-22

PROJECT NO.  
050329AS  
SHEET  
**41**  
OF 45

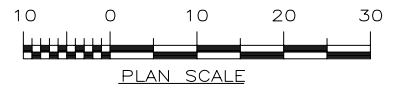
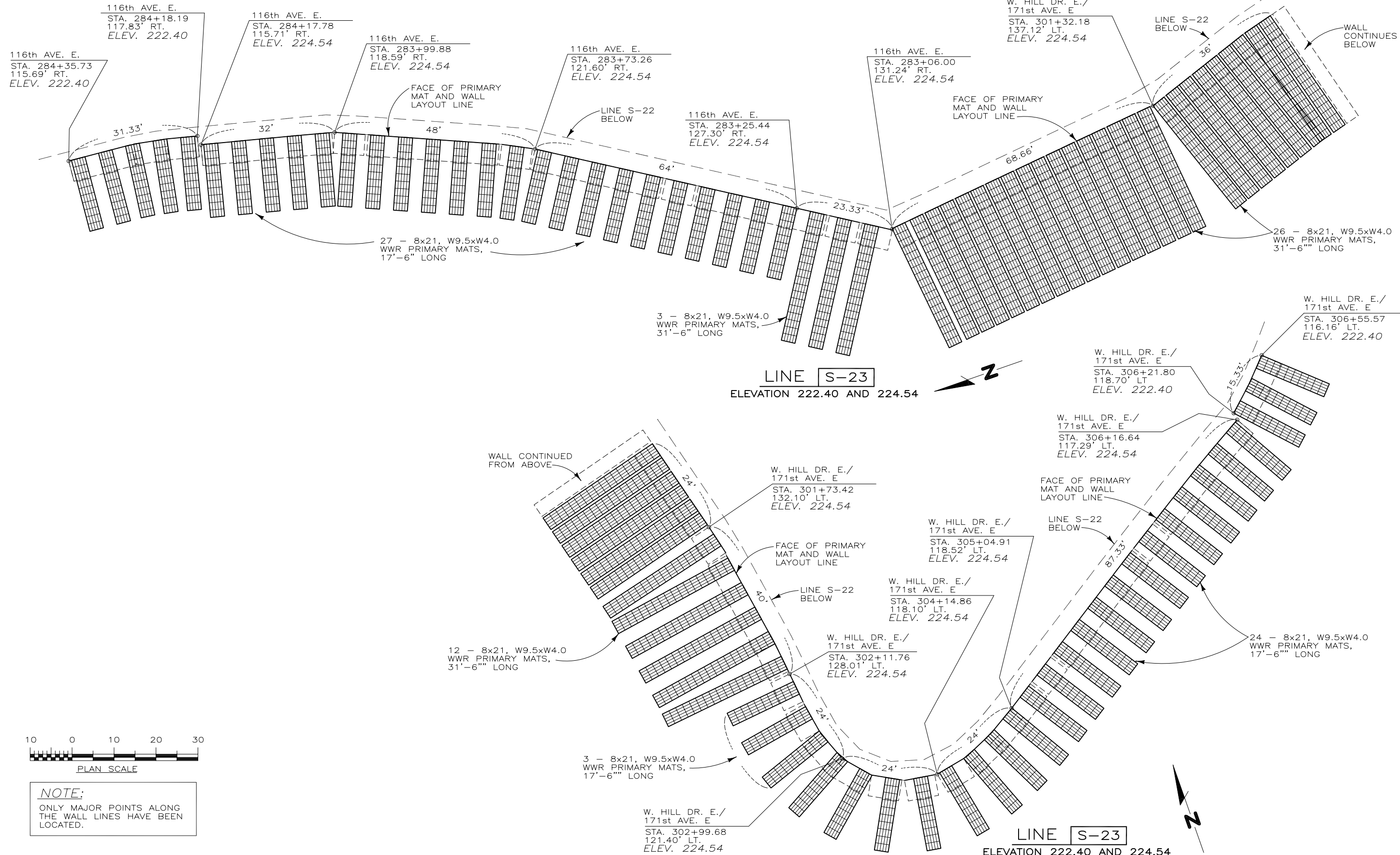

**NOTE:**  
ONLY MAJOR POINTS ALONG THE WALL LINES HAVE BEEN LOCATED.

050329AS PANORAMA WALL S

THIS DRAWING IS FURNISHED SOLELY FOR THE USE OF OR IN CONNECTION WITH THIS PROJECT, AND THE PROPRIETARY INFORMATION SHOWN HEREON IS NOT TO BE TRANSMITTED TO ANY OTHER ORGANIZATION WITHOUT SPECIFIC AUTHORIZATION BY THE HILFIKER COMPANY. HILFIKER RETAINING WALLS ARE PROTECTED BY ONE OR MORE OF THE FOLLOWING PATENTS: 3,631,682, 4,117,686, 4,260,296, 4,329,089, 4,324,508, 4,343,572, 4,391,557, 4,505,621, 4,516,959, 4,643,618, 4,661,023, 4,856,939, 5,733,072 AND OTHERS PENDING.

REV. NO.	DATE	BY	DESCRIPTION

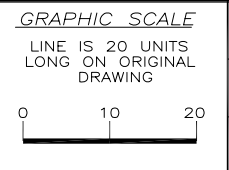

PROJ. MGR.  
WBH  
ENGINEER  
CADD BY  
DR

**HILFIKER RETAINING WALLS**  
3900 Broadway Eureka, CA 95503  
P.O. Box 2012 Eureka, CA 95501  
707-443-5093 Fax 707-443-2891  
Toll-Free 800-762-8962  
Web: <http://hilfiker.com> email: [info@hilfiker.com](mailto:info@hilfiker.com)

DWG DATE  
11 AUG 05  
REVISION DATE  
SCALE  
NOTED

**SHOP DRAWING**  
STEEPENED SLOPE  
**PANORAMA WEST SUBDIVISION**  
WALL S  
PIERCE COUNTY, WASHINGTON  
LINE S-23

PROJECT NO.  
050329AS  
SHEET  
**42**  
OF 45

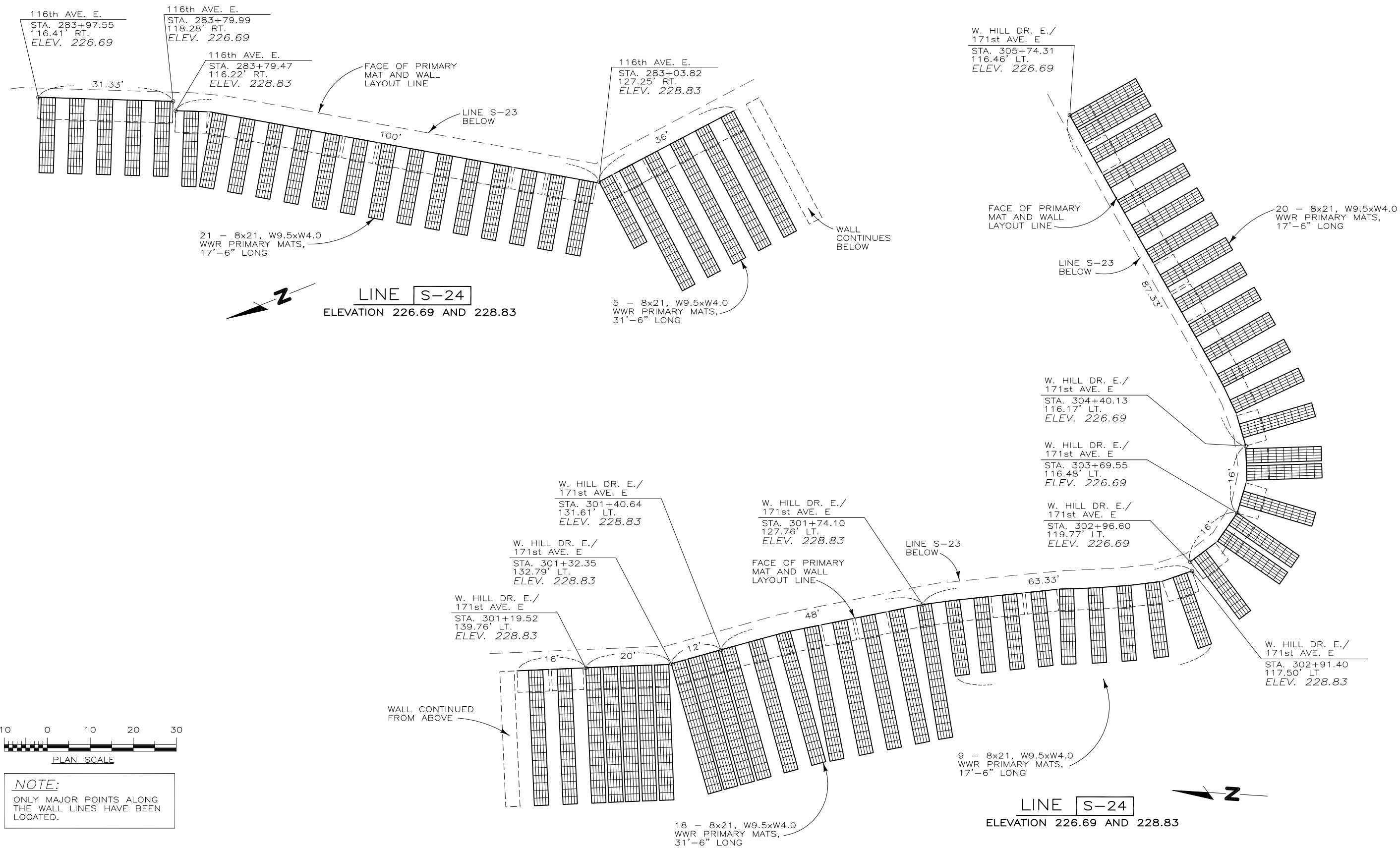

**NOTE:**  
ONLY MAJOR POINTS ALONG THE WALL LINES HAVE BEEN LOCATED.

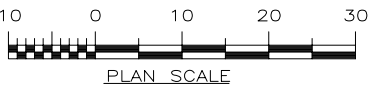

050329AS PANORAMA WALL S

THIS DRAWING IS FURNISHED SOLELY FOR THE USE OF OR IN CONNECTION WITH THIS PROJECT, AND THE PROPRIETARY INFORMATION SHOWN HEREON IS NOT TO BE TRANSMITTED TO ANY OTHER ORGANIZATION WITHOUT SPECIFIC AUTHORIZATION BY THE HILFIKER COMPANY. HILFIKER RETAINING WALLS ARE PROTECTED BY ONE OR MORE OF THE FOLLOWING PATENTS: 3,631,682, 4,117,686, 4,260,296, 4,329,089, 4,324,508, 4,343,572, 4,391,557, 4,505,621, 4,616,959, 4,643,618, 4,661,023, 4,856,939, 5,733,072 AND OTHERS PENDING.

REV. NO.	DATE	BY	DESCRIPTION

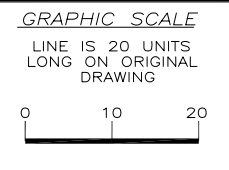

PROJ. MGR.  
WBH  
ENGINEER  
CADD BY  
DR

**HILFIKER RETAINING WALLS**  
3900 Broadway Eureka, CA 95503  
P.O. Box 2012 Eureka, CA 95501  
707-443-5093 Fax 707-443-2891  
Toll-Free 800-762-8962  
Web: <http://hilfiker.com> email: [info@hilfiker.com](mailto:info@hilfiker.com)



DWG DATE  
11 AUG 05  
REVISION DATE  
SCALE  
NOTED

**SHOP DRAWING**  
STEEPENED SLOPE  
**PANORAMA WEST SUBDIVISION**  
WALL S  
PIERCE COUNTY, WASHINGTON  
LINE S-24

PROJECT NO.  
050329AS  
SHEET  
**43**  
OF 45

116th AVE. E.  
STA. 283+62.72  
116.05' RT.  
ELEV. 230.98

116th AVE. E.  
STA. 283+42.38  
118.19' RT.  
ELEV. 230.98

116th AVE. E.  
STA. 283+41.65  
116.13' RT.  
ELEV. 233.12

116th AVE. E.  
STA. 238+01.85  
122.94' RT.  
ELEV. 233.12

W. HILL DR. E./  
171st AVE. E.  
STA. 301+30.60  
128.97' LT.  
ELEV. 233.12

W. HILL DR. E./  
171st AVE. E.  
STA. 301+75.48  
123.38' LT.  
ELEV. 233.12

W. HILL DR. E./  
171st AVE. E.  
STA. 302+28.91  
118.96' LT.  
ELEV. 230.98

W. HILL DR. E./  
171st AVE. E.  
STA. 302+24.61  
117.19' LT.  
ELEV. 233.12

W. HILL DR. E./  
171st AVE. E.  
STA. 302+61.80  
116.71' LT.  
ELEV. 230.98

19 - 8x21, W9.5xW4.0  
WWR PRIMARY MATS,  
17'-6" LONG

6 - 8x21, W9.5xW4.0  
WWR PRIMARY MATS,  
31'-6" LONG

15 - 8x21, W9.5xW4.0  
WWR PRIMARY MATS,  
17'-6" LONG

LINE S-25  
ELEVATION 230.98 AND 233.12



116th AVE. E.  
STA. 283+10.57  
119.29' RT.  
ELEV. 235.27

116th AVE. E.  
STA. 283+23.08  
116.88' RT.  
ELEV. 235.27

116th AVE. E.  
STA. 283+09.55  
117.28' RT.  
ELEV. 237.42

116th AVE. E.  
STA. 283+01.66  
118.62' RT.  
ELEV. 237.42

116th AVE. E.  
STA. 282+98.42  
120.41' RT.  
ELEV. 237.42

W. HILL DR. E./  
171st AVE. E.  
STA. 301+32.25  
124.16' LT.  
ELEV. 237.42

W. HILL DR. E./  
171st AVE. E.  
STA. 301+89.15  
118.96' LT.  
ELEV. 235.27

W. HILL DR. E./  
171st AVE. E.  
STA. 301+88.54  
116.99' LT.  
ELEV. 237.42

W. HILL DR. E./  
171st AVE. E.  
STA. 302+06.03  
117.39' LT.  
ELEV. 235.27

FACE OF PRIMARY  
MAT AND WALL  
LAYOUT LINE

31 - 8x21, W9.5xW4.0  
WWR PRIMARY MATS,  
17'-6" LONG  
ALL OF LINE S-26

LINE S-26  
ELEVATION 235.27 AND 237.42

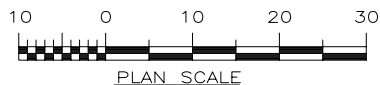

**NOTE:**  
ONLY MAJOR POINTS ALONG  
THE WALL LINES HAVE BEEN  
LOCATED.

050329AS PANORAMA WALL S

THIS DRAWING IS FURNISHED SOLELY FOR THE USE OF OR IN CONNECTION WITH THIS PROJECT, AND THE PROPRIETARY INFORMATION SHOWN HEREON IS NOT TO BE TRANSMITTED TO ANY OTHER ORGANIZATION WITHOUT SPECIFIC AUTHORIZATION BY THE HILFIKER COMPANY. HILFIKER RETAINING WALLS ARE PROTECTED BY ONE OR MORE OF THE FOLLOWING PATENTS: 3,631,682, 4,117,686, 4,260,296, 4,329,089, 4,324,508, 4,343,572, 4,391,557, 4,505,621, 4,616,959, 4,643,618, 4,661,023, 4,856,939, 5,733,072 AND OTHERS PENDING.

REV. NO.	DATE	BY	DESCRIPTION

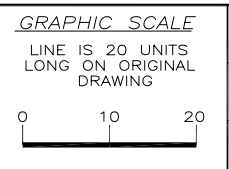

PROJ. MGR.  
WBH  
ENGINEER  
CADD BY  
DR

**HILFIKER RETAINING WALLS**  
3900 Broadway Eureka, CA 95503  
P.O. Box 2012 Eureka, CA 95501  
707-443-5093 Fax 707-443-2891  
Toll-Free 800-762-8962  
Web: <http://hilfiker.com> email: [info@hilfiker.com](mailto:info@hilfiker.com)



DWG DATE  
11 AUG 05  
REVISION DATE  
SCALE  
NOTED

**SHOP DRAWING**  
STEEPENED SLOPE  
**PANORAMA WEST SUBDIVISION**  
WALL S  
PIERCE COUNTY, WASHINGTON  
LINE S-25 AND S-26

PROJECT NO.  
050329AS  
SHEET  
**44**  
OF 45

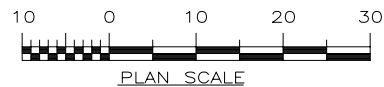
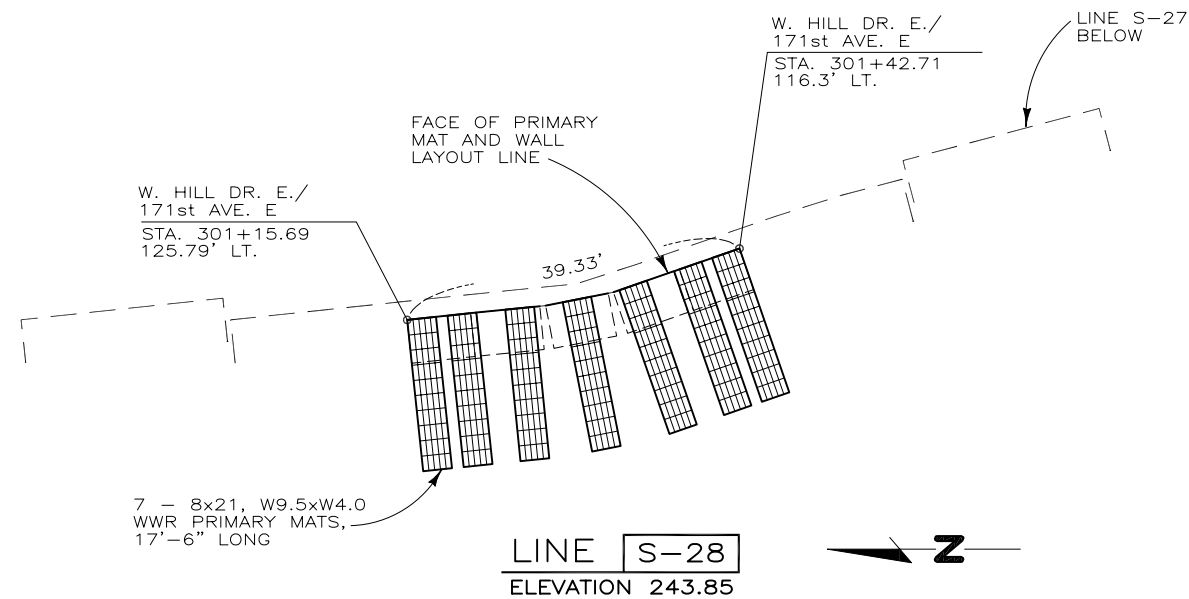
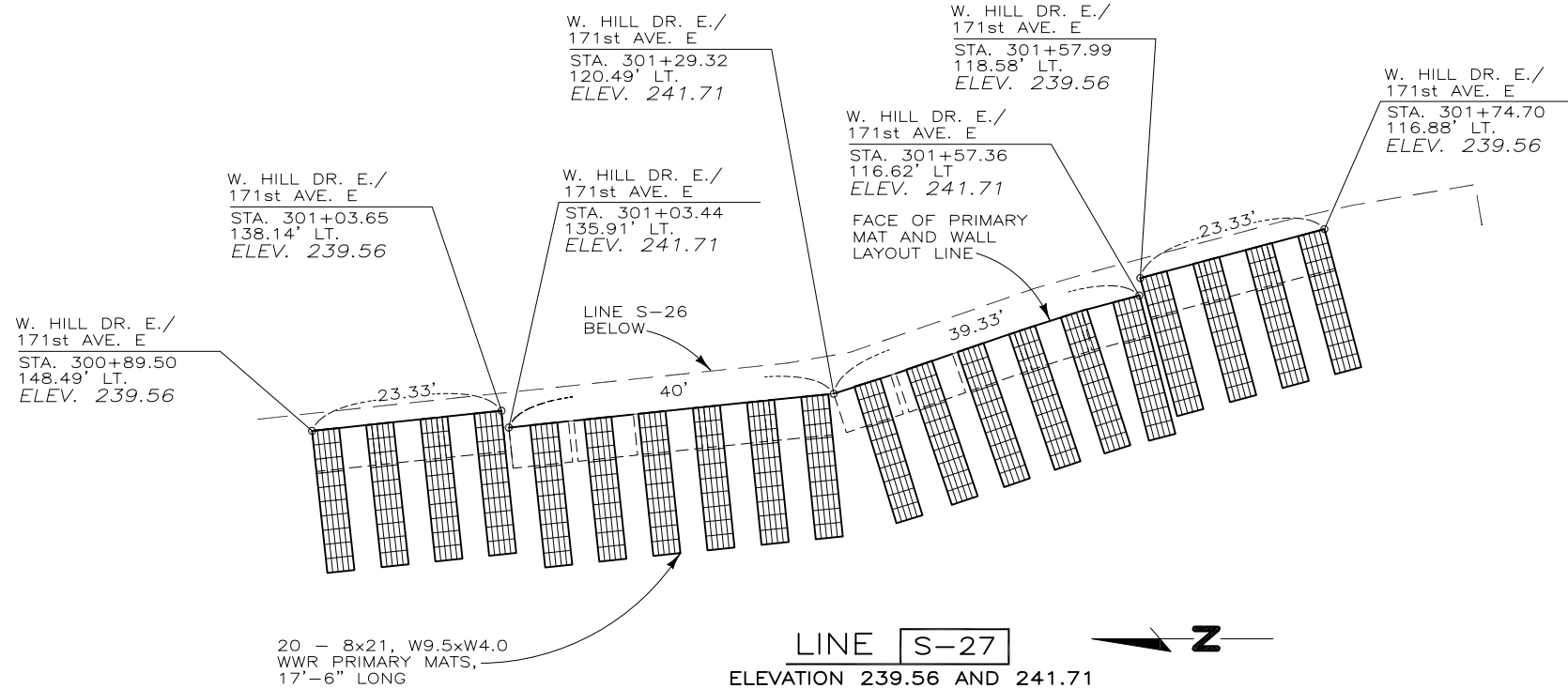

**NOTE:**  
ONLY MAJOR POINTS ALONG  
THE WALL LINES HAVE BEEN  
LOCATED.

050329AS PANORAMA WALL S

THIS DRAWING IS FURNISHED SOLELY FOR THE USE OF OR IN CONNECTION WITH THIS PROJECT, AND THE PROPRIETARY INFORMATION SHOWN HEREON IS NOT TO BE TRANSMITTED TO ANY OTHER ORGANIZATION WITHOUT SPECIFIC AUTHORIZATION BY THE HILFIKER COMPANY. HILFIKER RETAINING WALLS ARE PROTECTED BY ONE OR MORE OF THE FOLLOWING PATENTS: 3,631,682, 4,117,686, 4,260,296, 4,329,089, 4,324,508, 4,343,572, 4,391,557, 4,505,621, 4,616,959, 4,643,618, 4,661,023, 4,856,939, 5,733,072 AND OTHERS PENDING.

REV. NO.	DATE	BY	DESCRIPTION

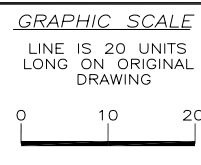

PROJ. MGR.  
WBH

ENGINEER

CADD BY  
DR

**HILFIKER RETAINING WALLS**  
3900 Broadway Eureka, CA 95503  
P.O. Box 2012 Eureka, CA 95501  
707-443-5093 Fax 707-443-2891  
Toll-Free 800-762-8962  
Web: <http://hilfiker.com> email: [info@hilfiker.com](mailto:info@hilfiker.com)



DWG DATE  
11 AUG 05

REVISION DATE

SCALE  
NOTED

**SHOP DRAWING**  
STEEPENED SLOPE  
**PANORAMA WEST SUBDIVISION**  
WALL S  
PIERCE COUNTY, WASHINGTON  
LINE S-27 AND S-28

PROJECT NO.  
050329AS

SHEET  
**45**  
OF 45